

aerospace
climate control
electromechanical
filtration
fluid & gas handling
hydraulics
pneumatics
process control
sealing & shielding



Automation Products

Grippers, Slide and Rotary Tables, Escapements

Catalog 0970



ENGINEERING YOUR SUCCESS.

The Parker 5-Year Extended Warranty

Parker Hannifin Corporation will extend its warranty on all pneumatic components to sixty (60) months providing they are correctly installed and protected by Parker pneumatic filters which are properly maintained. Components covered by this warranty include all cylinders, valves, and pneumatic automation components manufactured by Parker in any of our global facilities. This warranty covers our components anywhere in the world you may ship your equipment.

Parker's obligation under this warranty is limited to the replacement or repair of any failed components. The buyer understands that the seller will not be liable for any other costs or damages.

The buyers of quality Parker components and filters benefit by having ONE source for all pneumatic needs - Parker.



Yoon Chung
Yoon "Michael" Chung
President
Automation Group



WARNING

FAILURE OR IMPROPER SELECTION OR IMPROPER USE OF THE PRODUCTS AND/OR SYSTEMS DESCRIBED HEREIN OR RELATED ITEMS CAN CAUSE DEATH, PERSONAL INJURY AND PROPERTY DAMAGE.

This document and other information from Parker Hannifin Corporation, its subsidiaries and authorized distributors provide product and/or system options for further investigation by users having technical expertise. It is important that you analyze all aspects of your application including consequences of any failure, and review the information concerning the product or system in the current product catalog. Due to the variety of operating conditions and applications for these products or systems, the user, through its own analysis and testing, is solely responsible for making the final selection of the products and systems and assuring that all performance, safety and warning requirements of the application are met.

The products described herein, including without limitation, product features, specifications, designs, availability and pricing, are subject to change by Parker Hannifin Corporation and its subsidiaries at any time without notice.

Offer of Sale

The items described in this document are hereby offered for sale by Parker Hannifin Corporation, its subsidiaries or its authorized distributors. This offer and its acceptance are governed by the provisions stated on the separate page of this document entitled "Offer of Sale".

Introduction 2

Features and Benefits 3

Gripper Automation Summary 4

Angular Gripper

 P5GA - Economy 5-6

Parallel Grippers

 P5GB - Economy 7-8

 P5GV - Miniature Clean Room 9-10

 P5GR - High Precision 11-13

 P5GU - Clean Room, Harsh Environment 14-16

 P5GN - Compact Parallel 17-19

 P5GM - Parallel 20-22

 P5GS - Parallel, Wide Body 23-25

 P5GT - Parallel, Double Wedge 26-28

Electric Grippers

 P5GP 29-30

 P5GQ - High Force 31-32

3-Jaw Gripper

 P5GW 33-36

Slide Tables

 P5SS - Linear 37-48

Rotary Tables

 P5RS - Rotary 49-50

Escapement

 P5MD 51-52

Sensors 53-56





Fittings 57

Safety Guide 58-59

Offer of Sale 60

Complete Automation Solution

Parker Pneumatic Division is a single source supplier for all your automation needs. Selecting the right product for your application is easy with Parker Hannifin's extensive offering of pneumatic grippers, slide tables, rotary tables, and escapements. Integration into your automation system is fast and simple using a variety of online e-configurators and CAD drawings.

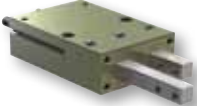
Hold		Index	Rotate	Feed
Economy Grippers	Precision Grippers	Slide Tables	Rotary Tables	Escapements
				



Extensive Offering.
Easy Integration.
Single Source.

Features and Benefits

Hold

Economy grippers

- Cost effective solution for machine builders
- Angular and Parallel
- 12mm to 32mm bore

Precision grippers

- Premium product for precision and durability
- Repeatability to + 0.00005mm
- Parallel 2 and 3 jaw
- Strokes to 73.5mm
- Grip forces to 44,000 N
- Clean room
- Electric grippers



Index

Slide tables

- Built in linear rail
- Bore size 6-25mm
- Available with stroke adjusters and shock absorbers



Rotate

Rotary table

- Twin rack and pinion rotary with integrated table
- Rotation adjustment standard 0-190 degrees
- Available with shock absorbers
- Hollow shaft standard for wiring and piping



Feed

Escapements

- Most effective mechanism for separating parts fed from conveyor
- Thrust force to 400 N
- Adjustable retract

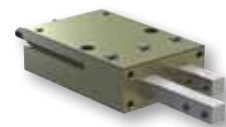

Grippers

	Series	Type	Grip force max.	mm or degrees of stroke	Spring open	Spring close	Clean room	Page number
	P5GA	Angular	13 N to 194 N	-10° to 30°	No	No	No	5
	P5GB	Parallel	16 N to 130 N	6mm to 16mm	No	No	No	7
	P5GV	Parallel	36 N	3.2mm to 6.3mm	No	No	Yes	9
	P5GR	Parallel	120 N to 458 N	6.4mm to 38.1mm	No	Yes	Yes	11
	P5GU	Parallel	116 N to 160 N	6.5mm to 25.4mm	No	No	Yes	14
	P5GN	Parallel	62 N to 445 N	1.6mm to 9.5mm	No	No	Yes	17
	P5GM	Parallel	62 N to 445 N	4.8mm to 25.4mm	No	No	Yes	20
	P5GS	Parallel	222 N to 800 N	19.1mm to 73.5mm	No	No	No	23
	P5GT	Parallel	178 N to 2669 N	6.4mm to 50.8mm	No	No	No	26
	P5GP	Electric	111 N	0mm to 25mm	No	No	No	29
	P5GQ	Electric	445 N to 1334 N	10mm to 20mm	No	No	No	31
	P5GW	3-Jaw	682 N to 44354 N	4.0mm to 35mm	No	Yes	Yes	33

- Angular gripper, 2-finger - economy
- Comprehensive range of bore sizes, 12mm to 32mm
- Magnetic piston standard



Operating information

Operating pressure:	1.5 to 7 bar (21.8 to 102 PSIG)
Temperature range:	-5° to 60° C (23° to 140° F)
Maximum frequency:	180 cycles/min

Ordering Information: P5GA Angular Gripper Series - Economy

Function	Bore size (mm)	Ports (BSP)	Rotation	Weight (g)	Part number
Double acting magnetic	12	M3	-10 to 30 degrees	53	P5GA-012MSG030B
Double acting magnetic	16	M5	-10 to 30 degrees	103	P5GA-016MSG030B
Double acting magnetic	20	M5	-10 to 30 degrees	193	P5GA-020MSG030B
Double acting magnetic	25	M5	-10 to 30 degrees	327	P5GA-025MSG030B
Double acting magnetic	32	M5	-10 to 30 degrees	525	P5GA-032MSG030B

Sensor part numbers: Page 53.

Most popular.

Clamp Force - P5GA-012

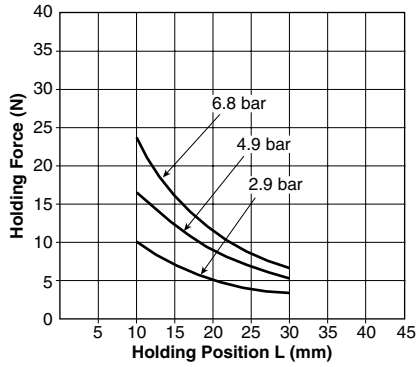

Clamp Force - P5GA-016

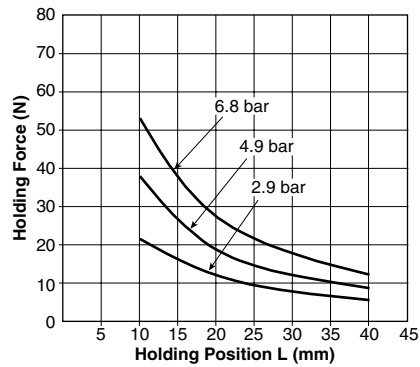

Clamp Force - P5GA-020

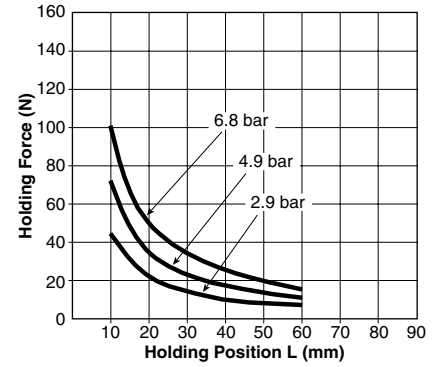

Clamp Force - P5GA-025

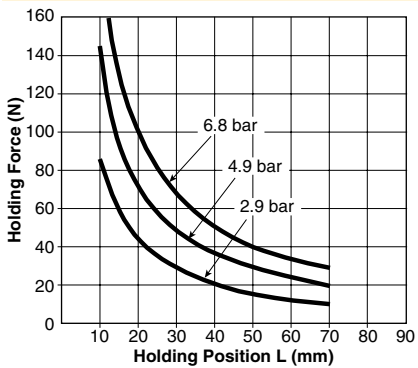

Clamp Force - P5GA-032

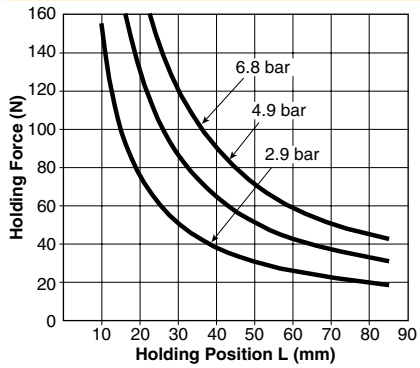

Dimensions: P5GA Angular Gripper Series - Economy

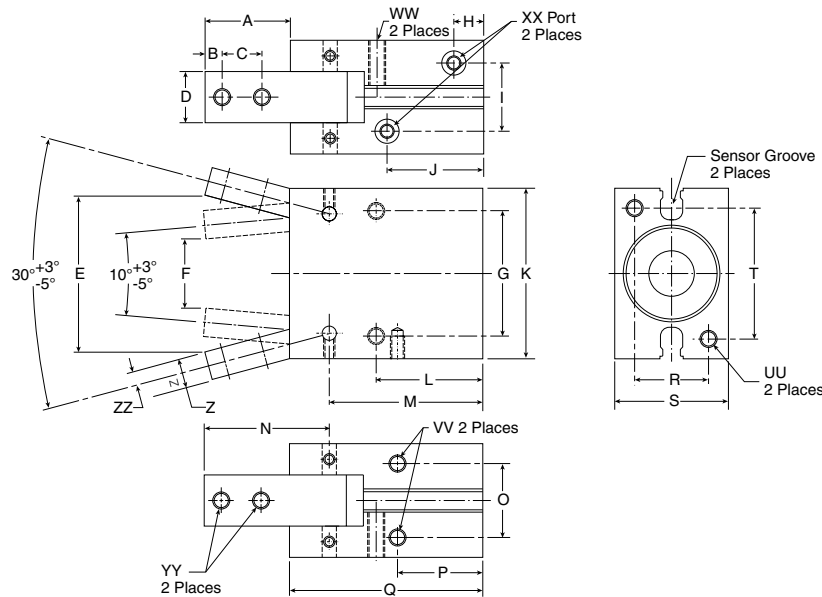

Tube

I.D.	A	B	C	D	E	F	G	H	I	J	K	L	M	N	O	P	Q	R	S	T	UU	VV	WW	XX	YY	Z	ZZ
12	15.4	3	6	7	26.3	9	20	7.5	10.2	23.5	28	20	32.9	21.5	10.2	16	39	10	16	22	M3	M3	M3	M3	M3	5	2.5
16	17.5	3	8	9	31.1	14	24	7.5	12	22	34	22.5	35	25	14	18	42.5	14	22	26	M4	M4	M4	M5	M3	6	3
20	22	4	10	12	40.1	18	30	8	13	25	45	25	39.5	32.5	16	19	50	16	26	35	M5	M5	M5	M5	M4	7	3.5
25	26	5	12	14	47.9	21	36	8.5	18	28	52	28.5	45.5	38.5	20	21.5	58	20	32	40	M6	M6	M6	M5	M5	9	4
32	30	6	14	18	55.1	24	44	10.5	24	34	60	37.5	54	44	26	30	68	26	40	46	M6	M6	M6	M5	M6	10	5

Dimensions in millimeters



- Parallel gripper, 2-finger - economy
- Comprehensive range of bore sizes, 12mm to 32mm
- Magnetic piston standard



Operating information

Operating pressure: 1.5 to 7 bar (21.8 to 102 PSIG)
 Temperature range: -5° to 60° C (23° to 140° F)
 Maximum frequency: 180 cycles/min

Ordering Information: P5GB Parallel Gripper Series - Economy

Function	Bore size (mm)	Ports (BSPP)	Stroke (mm)	Weight (g)	Part number
Double acting magnetic	12	M3	6	66	P5GB-012MSG006B
Double acting magnetic	16	M5	8	144	P5GB-016MSG008B
Double acting magnetic	20	M5	12	255	P5GB-020MSG012B
Double acting magnetic	25	M5	14	419	P5GB-025MSG014B
Double acting magnetic	32	M5	16	719	P5GB-032MSG016B

Sensor part numbers: Page 53.

Clamp Force - P5GB-012

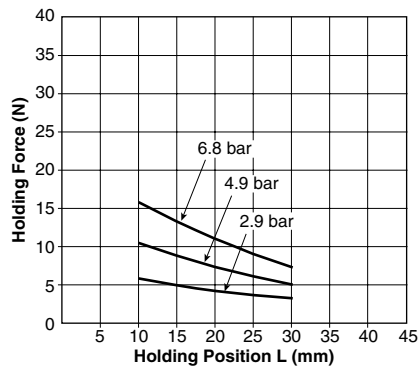

Clamp Force - P5GB-016

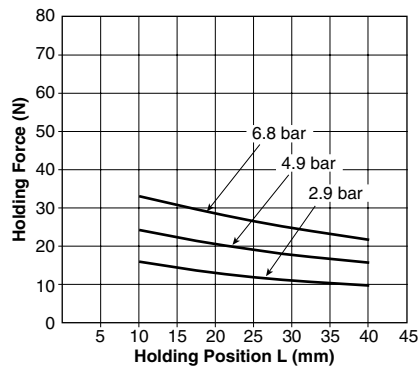

Clamp Force - P5GB-020

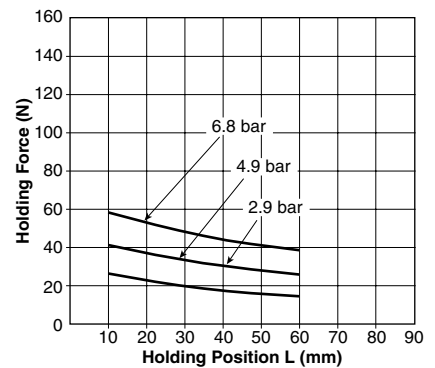

Clamp Force - P5GB-025

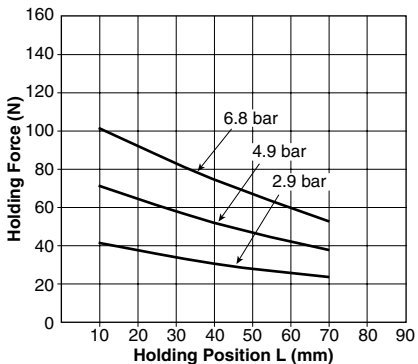

Clamp Force - P5GB-032

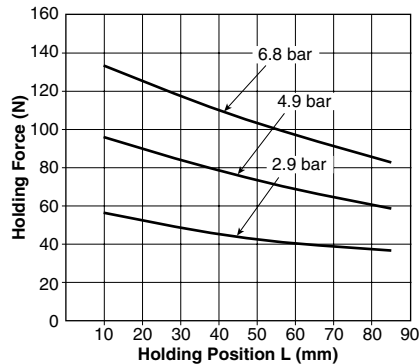

 Most popular.

Dimensions: P5GB Parallel Gripper Series - Economy

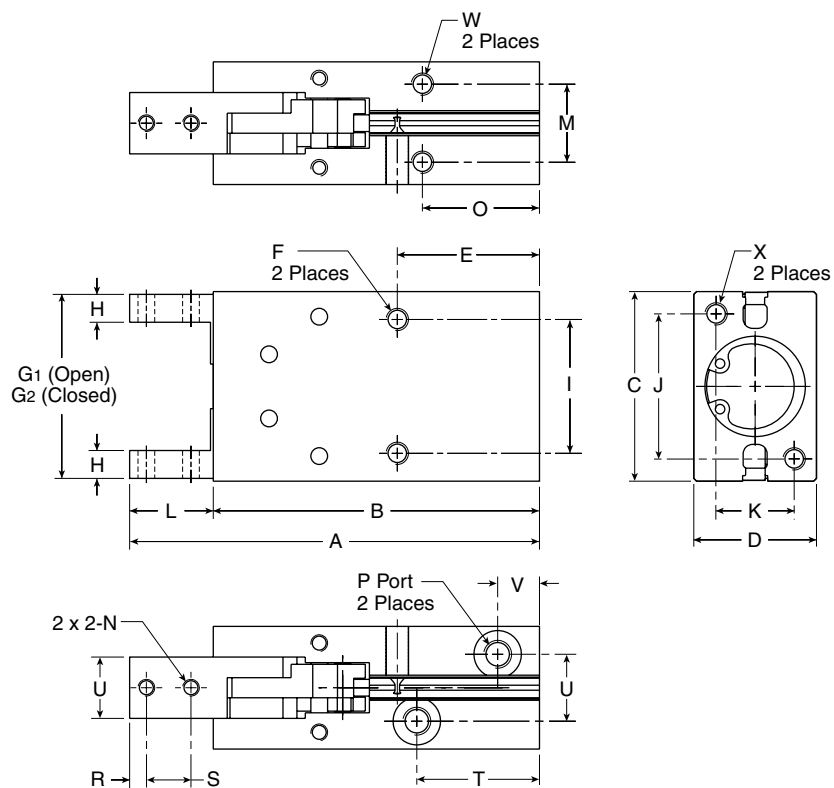

Tube I.D.	A	B	C	D	E	F	G1	G2	H	I	J	K	L	M	N	O	P	Q	R	S	T	U
12	63.5	50.5	28	16	20	M3 x 0.5 x 5 Dp	27	21	4	18	17	10	13	10	M3 x 0.5	16	M3	7	3	6	23	10.2
16	73.5	58.5	34	22	25.5	M4 x 0.7 x 11 Dp	33	25	5	24	26	14	15	14	M3 x 0.5	21	M5	11	3	8	22	12
20	88.5	69.5	45	26	25	M5 x 0.8 x 8 Dp	44	32	6	30	35	16	19	16	M3 x 0.7	19	M5	12	4	10	26	13
25	102.5	78.5	52	32	28	M6 x 1.0 x 10 Dp	51	37	8	36	40	20	24	20	M3 x 0.8	22	M5	14	5	12	29	18
32	120.5	90.5	60	40	34	M6 x 1.0 x 10 Dp	59	43	10	44	46	24	30	26	M3 x 1.0	26	M5	20	7	15	35	24

Tube I.D.	V	W	X
12	7.5	M3 x 0.5 x 5 Dp	M3 x 0.5 x 5 Dp
16	7.5	M4 x 0.7 x 7 Dp	M4 x 0.7 x 7 Dp
20	8	M5 x 0.8 x 8 Dp	M5 x 0.8 x 8 Dp
25	8.5	M6 x 1.0 x 10 Dp	M6 x 1.0 x 10 Dp
32	10.5	M6 x 1.0 x 10 Dp	M6 x 1.0 x 10 Dp

Dimensions in millimeters

- One piece lightweight aluminum body
- Stationary and non-contacting stainless steel cover eliminates the possibility of particle generation
- Bearings are preloaded for maximum support and zero side play
- The body has hard-coat anodize 60 RC with PTFE impregnation
- Units are lubricated with a clean-room grade grease
- Purge / scavenge port for extreme environments from dirty and gritty to clean-room class 10 or better
- Adjustable preload screw allows for adjustment of preload on roller bearings
- External components are made from corrosion resistant materials for resistance to de-ionized water or for use in FDA and medical parts handling applications
- Slip fit dowel pin holes located in body and jaws

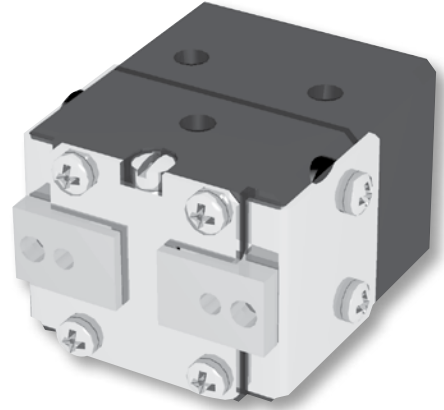

Operating information

Operating pressure:	3 to 7 bar (44 to 102 PSIG)
Temperature range:	
Nitrile seals (standard)	-35° to 80° C (-30° to 180° F)
Fluorocarbon seals (optional)	-30° to 120° C (-20° to 250° F)
Filtration requirements:	
Air filtration	40 micron or better
Air lubrication	Not necessary*
Air humidity	Low moisture content (dry)

*Addition of lubrication will greatly increase service life

Ordering Information: P5GV Miniature Clean Room Series

Function	Bore size (mm)	Ports (BSPP)	Stroke (mm)	Grip force @ 7 bar (N)	Accuracy +/- mm	Repeatability +/-mm	Weight (kg)	Part number
Double acting magnetic, Nitrile	10	M3	3.2	36	0.05	0.03	0.024	P5GV-010MSG003B
Double acting magnetic, Fluorocarbon	10	M3	3.2	36	0.05	0.03	0.024	P5GV-010MFG003B
Double acting magnetic, Nitrile	10	M3	4.8	36	0.05	0.03	0.026	P5GV-010MSG005B
Double acting magnetic, Fluorocarbon	10	M3	4.8	36	0.05	0.03	0.026	P5GV-010MFG005B
Double acting magnetic, Nitrile	10	M3	6.3	36	0.05	0.03	0.034	P5GV-010MSG006B
Double acting magnetic, Fluorocarbon	10	M3	6.3	36	0.05	0.03	0.034	P5GV-010MFG006B

Not available with sensors.

Most popular.

Loading information - P5GV

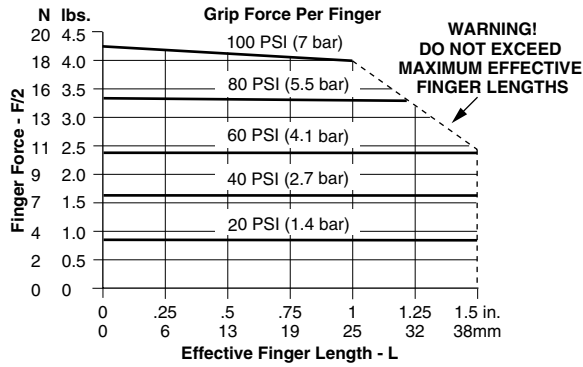

Loading capacity† - P5GV

	Static (metric)	Dynamic (metric)
Maximum tensile T	89 N	31 N
Maximum compressive C	89 N	31 N
Maximum moment Mx	1 Nm	0.5 Nm
Maximum moment My	2 Nm	0.6 Nm
Maximum moment Mz	1 Nm	0.5 Nm

† Capacities are per set of jaws and are not simultaneous

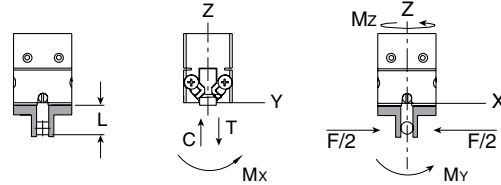

Dimensions: P5GV Miniature Clean Room Series

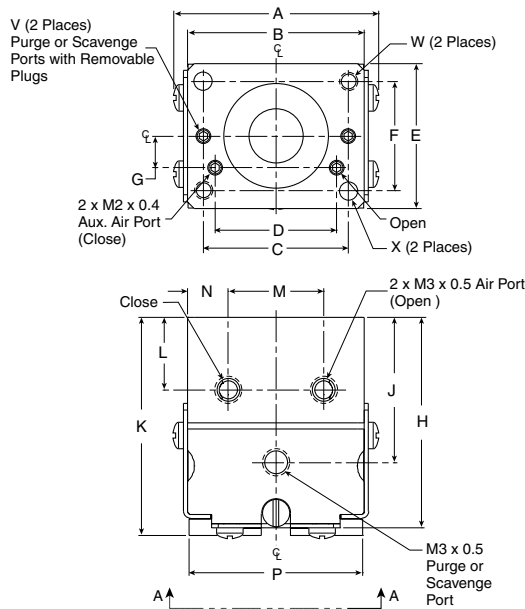

Unless otherwise noted all tolerances are as shown below

Dimensions are symmetrical about centerline
 Third Angle Projection
Metric (mm)
 (0.) = (±.25)
 (0.0) = (±.13)
 (0.00) = (±.013)

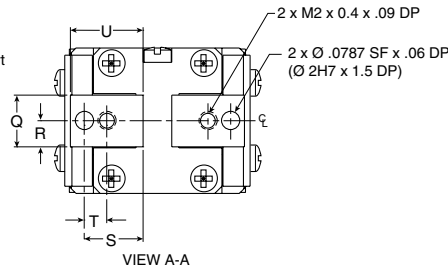

Part number	A	B	C	D	E	F	G	H	J	K	L	M
P5GV-010MS(F)G003B	23	19.5	16.0	13.4	16.0	12.00	3.5	23	16	24.0	8	10.5
P5GV-010MS(F)G005B	24	21.0	16.0	13.4	16.0	12.00	3.5	25	17	25.5	9	10.5
P5GV-010MS(F)G006B	30	26.5	20.0	13.4	16.0	11.00	3.5	25	18	25.5	10	10.5

Part number	N	P	Q	R	S	T	U	V	W	X
P5GV-010MS(F)G003B	4.5	Open 19.2 Closed 16	.569 ±0.03	2.8	6.50	2.5	8	M2 x 0.4	M2 x .18 4.5 Dp	Ø 2H7 x 3.3 Dp
P5GV-010MS(F)G005B	5.2	Open 20.8 Closed 16	.569 ±0.03	2.8	6.50	2.5	8	M2 x 0.4	M2 x 0.4 .18 Dp	Ø 2H7 x 3.3 Dp
P5GV-010MS(F)G006B	8.0	Open 126.4 Closed 20	.569 ±0.03	2.8	7.50	2.5	10	M2 x 0.5	M3 x 0.5 .20 Dp	Ø 3H7 x 5.0 Dp

Dimensions in millimeters

- Excellent parallelism and accuracy between gripper mounting surface and jaw surfaces
- H7 dowel pin holes in body and jaws. Jaws also have key slot for better finger alignment.
- Hardened plated jaws for wear resistance and longer life
- Top manifold air ports eliminates the need for airlines
- “Dual-V” roller bearings provide low friction motion and are preloaded for maximum support and zero side play
- One piece, aircraft quality aluminum body, has hard-coat anodized 60 RC with PTFE impregnation
- Standard purge / scavenge port used with vacuum for clean room environments or positive pressure for harsh environments and jaw surfaces
- Adjustable pre-load screws allows for adjustment of preload on roller bearings
- 4 standard air port locations; front, top and both sides
- Shielded design repels contamination from penetrating the “Dual-V” roller bearings
- Magnetic piston standard

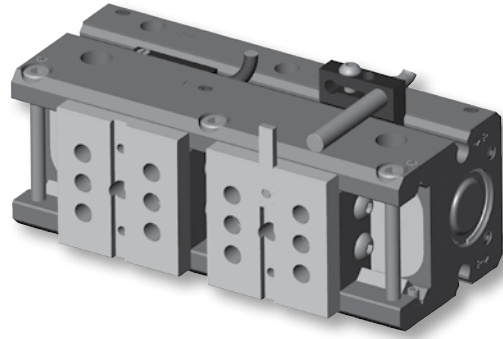

Operating information

Pressure range (without springs):	0.3 to 7 bar (4 to 102 PSIG)
Pressure range (with springs):	
P5GR-010MSG006B & P5GR-010MSG013B	1.4 to 7 bar (20 to 102 PSIG)
P5GR-014MSG016B & P5GR-014MSG025B	3.4 to 7 bar (49 to 102 PSIG)
P5GR-021MSG025B	2.8 to 7 bar (41 to 102 PSIG)
P5GR-021MSG038B	2.1 to 7 bar (30 to 102 PSIG)
Temperature range:	
Nitrile seals (standard)	-35° to 80° C (-30° to 180° F)
Filtration requirements:	
Air filtration	40 micron or better
Air lubrication	Not necessary*
Air humidity	Low moisture content (dry)

*Addition of lubrication will greatly increase service life

Ordering Information: P5GR High Precision Series

Function	Bore size (mm)	Ports (BSPP)	Stroke (mm)	Grip force @ 7 bar (N)	Accuracy +/- mm	Repeatability +/-mm	Weight (kg)	Part number
Double acting magnetic	10	M3	6.4	120	0.001	0.00005	0.16	P5GR-010MSG006B
Spring closing, magnetic	10	M3	6.4	120	0.001	0.00005	0.16	P5GR-010DSG006B
Double acting magnetic	10	M3	12.7	120	0.001	0.00005	0.20	P5GR-010MSG013B
Spring closing, magnetic	10	M3	12.7	120	0.001	0.00005	0.20	P5GR-010DSG013B
Double acting magnetic	14	M3	15.9	227	0.001	0.00005	0.48	P5GR-014MSG016B
Spring closing, magnetic	14	M3	15.9	227	0.001	0.00005	0.48	P5GR-014DSG016B
Double acting magnetic	14	M3	25.4	214	0.001	0.00005	0.57	P5GR-014MSG025B
Spring closing, magnetic	14	M3	25.4	214	0.001	0.00005	0.57	P5GR-014DSG025B
Double acting magnetic	21	M5	25.4	458	0.001	0.00005	1.02	P5GR-021MSG025B
Spring closing, magnetic	21	M5	25.4	458	0.001	0.00005	1.02	P5GR-021DSG025B
Double acting magnetic	21	M5	38.1	449	0.001	0.00005	1.41	P5GR-021MSG038B
Spring closing, magnetic	21	M5	38.1	449	0.001	0.00005	1.41	P5GR-021DSG038B

Sensor part numbers: Page 53.

Most popular.



Loading information - P5GR-010***006

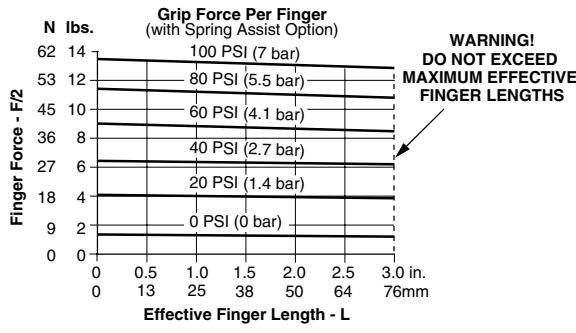

Loading information - P5GR-014***025

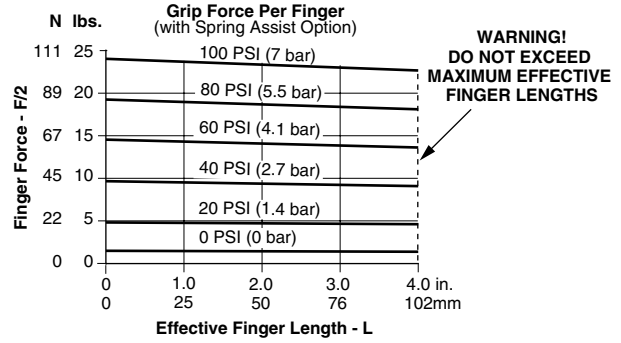

Loading information - P5GR-010***013

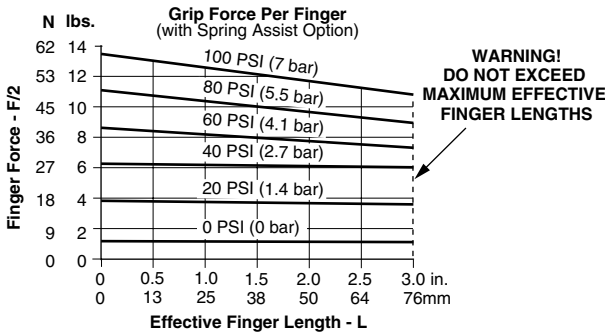

Loading information - P5GR-021***025

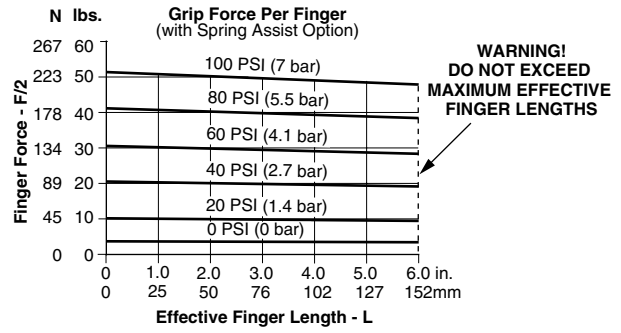

Loading information - P5GR-014...016

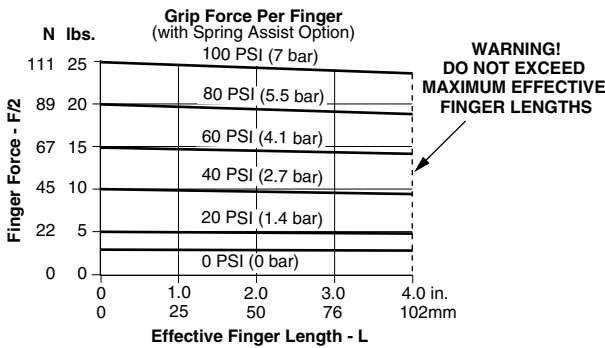

Loading information - P5GR-021***038

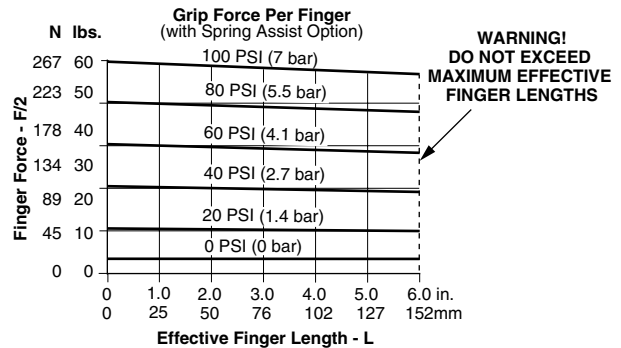

Loading capacity† - P5GR High Precision Series

	P5GR-010***006		P5GR-010***013		P5GR-014***016		P5GR-014***025		P5GR-021***025		P5GR-021***038	
	Static (metric)	Dynamic (metric)	Static (metric)	Dynamic (metric)	Static (metric)	Dynamic (metric)	Static (metric)	Dynamic (metric)	Static (metric)	Dynamic (metric)	Static (metric)	Dynamic (metric)
Maximum tensile T	267 N	89 N	311 N	102 N	556 N	187 N	734 N	245 N	667 N	222 N	890 N	245 N
Maximum compressive C	267 N	89 N	311 N	102 N	556 N	187 N	734 N	245 N	667 N	222 N	890 N	245 N
Maximum moment Mx	4.0 Nm	1.4 Nm	5.6 Nm	1.9 Nm	9.0 Nm	3.1 Nm	11 Nm	3.7 Nm	34 Nm	11 Nm	45 Nm	15 Nm
Maximum moment My	5.6 Nm	1.9 Nm	7.3 Nm	4.0 Nm	12 Nm	4.0 Nm	14 Nm	4.7 Nm	40 Nm	4.7 Nm	51 Nm	17 Nm
Maximum moment Mz	4.0 Nm	1.4 Nm	5.6 Nm	1.9 Nm	9.0 Nm	3.1 Nm	11 Nm	3.7 Nm	34 Nm	11 Nm	45 Nm	15 Nm

† Capacities are per set of jaws and are not simultaneous

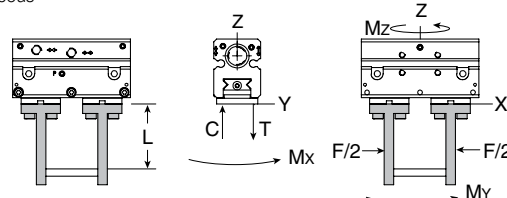

Dimensions: P5GR High Precision Series

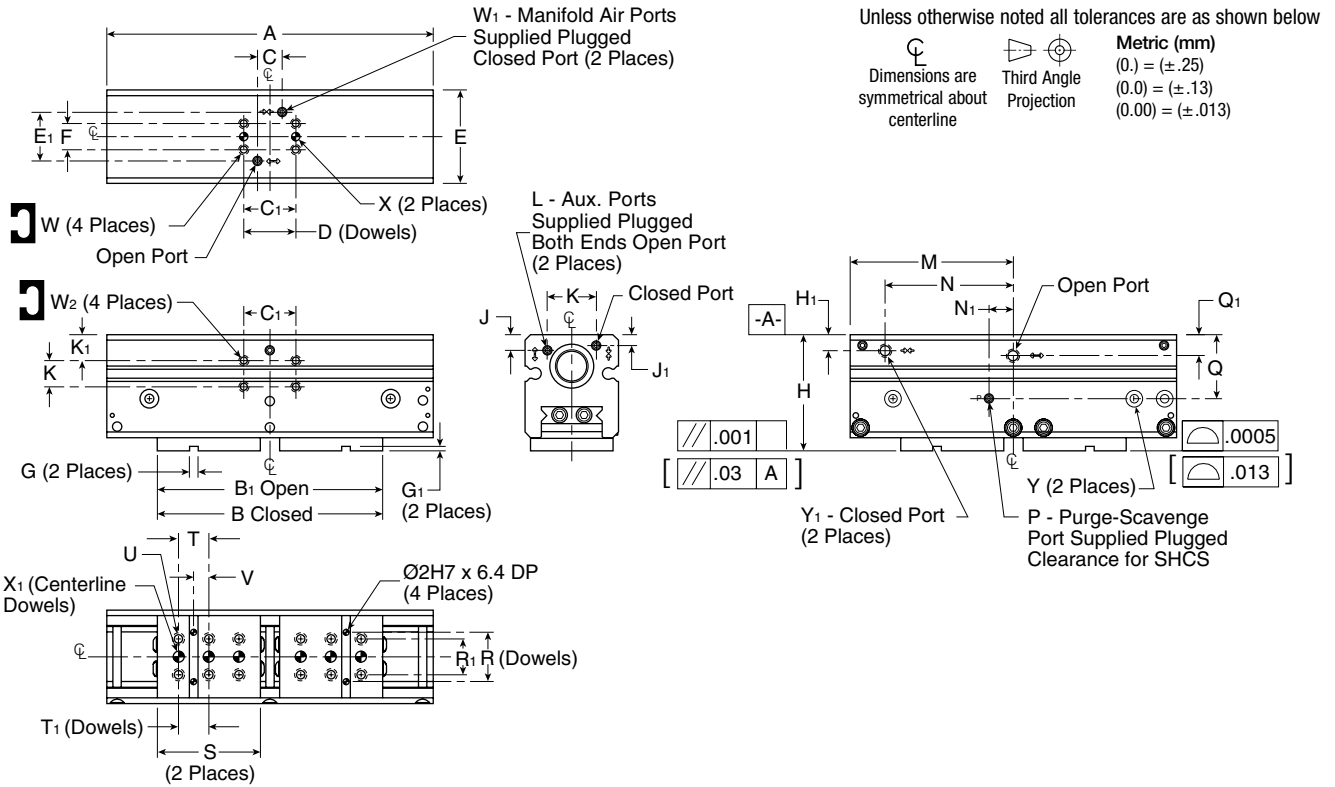

Part number	A	B	B1	C	C1	D	E	E1	F	G	G1	H	H1	J	J1	K	K1	L	M	N	N1	P
P5GR-010***006	62.9	47	53	8.9	19.1	19.05	25.0	15.2	9.5	3.15 ^{+0.02}	1.52 ^{+0.02}	34.67 ^{+0.02}	5.8	4.4	3.8	9.5	8.5	M3 x 3 Dp	31.4	18.7	5.1	M3 x 3 Dp
P5GR-010***013	73.7	49	62	8.9	19.1	19.05	25.0	15.2	9.5	3.15 ^{+0.02}	1.52 ^{+0.02}	34.67 ^{+0.02}	5.8	4.4	3.8	9.5	8.5	M3 x 3 Dp	36.8	24.1	5.1	M3 x 3 Dp
P5GR-014***016	90.2	63	79	8.9	19.1	19.05	34.0	17.8	9.5	3.15 ^{+0.02}	1.52 ^{+0.02}	42.21 ^{+0.02}	5.8	5.7	3.9	9.5	9.5	M3 x 3 Dp	45.1	32.4	8.9	M3 x 3 Dp
P5GR-014***025	118.7	82	107	8.9	19.1	19.05	34.0	17.8	9.5	3.15 ^{+0.02}	1.52 ^{+0.02}	42.21 ^{+0.02}	5.8	5.7	3.9	9.5	9.5	M3 x 3 Dp	59.4	46.7	8.9	M3 x 3 Dp
P5GR-021***025	129	89	115	12.7	38.1	38.10	46.0	28.7	19.1	3.15 ^{+0.02}	1.52 ^{+0.02}	55.63 ^{+0.02}	5.8	7.0	5.8	19.1	9.5	M5 x 5 Dp	64.5	45.5	14.0	M5 x 5 Dp
P5GR-021***038	175.5	123	161	12.7	38.1	38.10	46.0	28.7	19.1	3.15 ^{+0.02}	1.52 ^{+0.02}	55.63 ^{+0.02}	5.8	7.0	5.8	19.1	9.5	M5 x 5 Dp	87.8	68.7	14.0	M5 x 5 Dp

Part number	Q	Q1	R	R1	S	T	T1	U	V	W	W1	W2	X	X1	Y	Y1
P5GR-010***006	18.5	7.4	9.19	9.0	21	12	11.99	M3 x 5 Dp	6.0	M3 x 4 Dp	M3 x 3 Dp	M3 x 4 Dp	Ø3H7 x 2.5 Dp	Ø2H7 x 3.6 Dp	Ø6.35 x 3 Dp	M5 x 4 Dp
P5GR-010***013	18.5	7.4	9.20	9.0	21	12	11.99	M3 x 5 Dp	6.0	M3 x 4 Dp	M3 x 3 Dp	M3 x 4 Dp	Ø3H7 x 2.5 Dp	Ø2H7 x 3.6 Dp	Ø6.35 x 3 Dp	M5 x 4 Dp
P5GR-014***016	23.2	8.0	17.98	13.0	28	16	16.00	M4 x 7 Dp	8.0	M3 x 4 Dp	M3 x 3 Dp	M3 x 5 Dp	Ø3H7 x 2.5 Dp	Ø4H7 x 3.6 Dp	Ø6.35 x 3 Dp	M5 x 5 Dp
P5GR-014***025	23.2	8.0	17.98	13.0	37.5	11	11.00	M4 x 7 Dp	5.5	M3 x 4 Dp	M3 x 3 Dp	M3 x 5 Dp	Ø3H7 x 2.5 Dp	Ø4H7 x 3.6 Dp	Ø6.35 x 3 Dp	M5 x 5 Dp
P5GR-021***025	31.1	11.2	25.78	17.0	40.0	12.5	12.50	M5 x 10 Dp	6.2	M5 x 5 Dp	M5 x 5 Dp	M5 x 5 Dp	Ø5H7 x 3.0 Dp	Ø5H7 x 5.3 Dp	Ø6.35 x 3 Dp	M5 x 5 Dp
P5GR-021***038	31.1	11.2	25.78	17.0	58.0	16.0	16.00	M5 x 10 Dp	8.0	M5 x 5 Dp	M5 x 5 Dp	M5 x 5 Dp	Ø5H7 x 3.0 Dp	Ø5H x 5.3 Dp	Ø6.35 x 3 Dp	M5 x 5 Dp

Dimensions in millimeters

- Internal components are made from hardened bearing and tool steels. External components are made from corrosion resistant materials for resistance to de-ionized water or for use in FDA and medical parts handling applications.
- Stationary and non-contacting stainless steel shields eliminate the possibility of particle generation
- Adjustable preload screws allow for adjustment of preload on roller bearings
- The body has hard-coat anodized 60 RC with PTFE impregnation
- Dual “V” roller bearings provide low friction rolling motion. Roller bearings are preloaded for maximum support and zero side play.
- Units are lubricated with a clean room grade grease
- Slip fit dowel pin holes in body
- Purge / scavenge port for extreme environments from dirty and gritty to clean room Class 10 or better
- Stainless steel screws provide protection against corrosion
- Magnetic piston standard

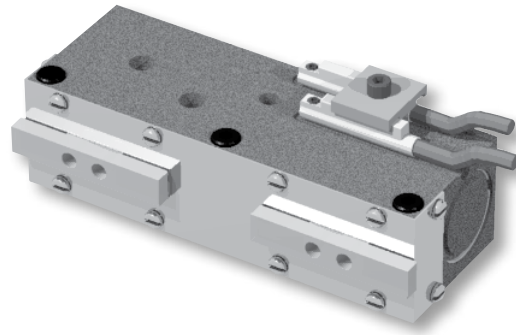

Operating information

Operating pressure:	0.3 to 7 bar (4 to 102 PSIG)
Temperature range:	
Standard seals	-35° to 80° C (-30° to 180° F)
Fluorocarbon seals	-30° to 120° C (-20° to 248° F)
Filtration requirements:	
Air filtration	40 micron or better
Air lubrication	Not necessary*
Air humidity	Low moisture content (dry)

*Addition of lubrication will greatly increase service life

Ordering Information: Clean Room Harsh Environment Series

Function	Bore size (mm)	Ports (BSP)	Stroke (mm)	Grip force @ 7 bar (N)	Accuracy +/- mm	Repeatability +/-mm	Weight (kg)	Part number
Double acting magnetic	11	M5	6.4	116	0.05	0.03	0.07	P5GU-011MSG006B
Double acting magnetic	11	M5	6.4	116	0.05	0.03	0.07	P5GU-011MFG006B
Double acting magnetic	11	M5	12.7	116	0.05	0.03	0.09	P5GU-011MSG013B
Double acting magnetic	11	M5	12.7	116	0.05	0.03	0.09	P5GU-011MFG013B
Double acting magnetic	13	M5	19.1	160	0.05	0.03	0.15	P5GU-013MSG019B
Double acting magnetic	13	M5	19.1	160	0.05	0.03	0.15	P5GU-013MFG019B
Double acting magnetic	13	M5	25.4	160	0.05	0.03	0.17	P5GU-013MSG025B
Double acting magnetic	13	M5	25.4	160	0.05	0.03	0.17	P5GU-013MFG025B

Sensor part numbers: Page 53.

Most popular.



Loading information - P5GU-011*006**

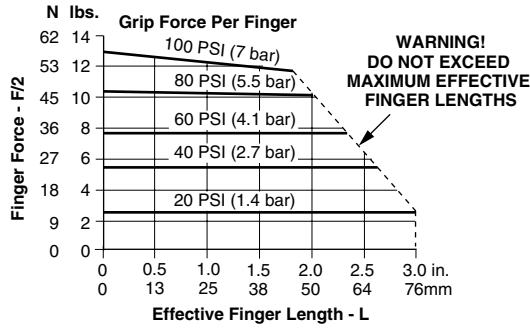

Loading information - P5GU-013*019**

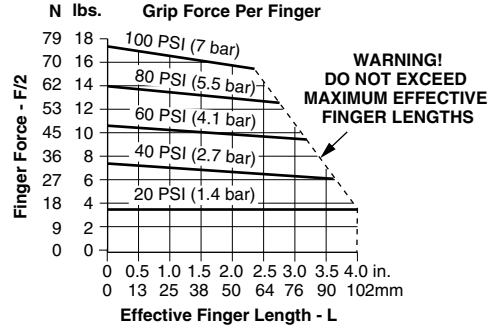

Loading information - P5GU-011*013**

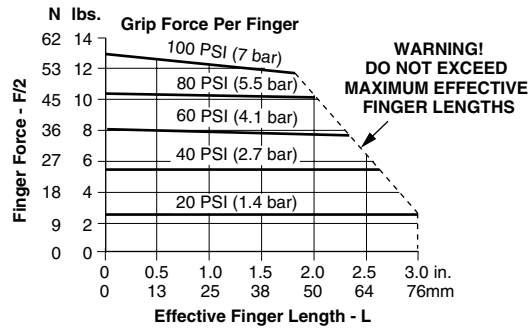

Loading information - P5GU-013*025**

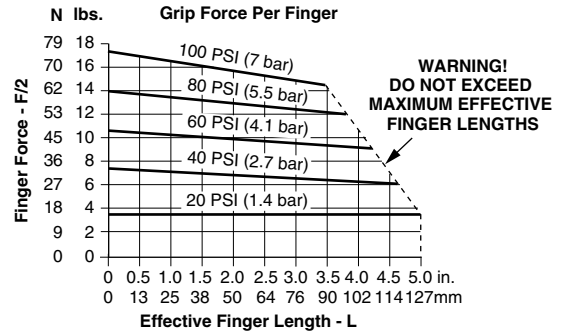

Loading capacity† - P5GU Clean Room Harsh Environment Series

	P5G-011***006		P5GU-011***013		P5GU-013***019		P5GU-013***025	
	Static (metric)	Dynamic (metric)	Static (metric)	Dynamic (metric)	Static (metric)	Dynamic (metric)	Static (metric)	Dynamic (metric)
Maximum tensile T	222 N	67 N	289 N	89 N	400 N	133 N	534 N	178 N
Maximum compressive C	222 N	67 N	289 N	89 N	400 N	133 N	534 N	178 N
Maximum moment Mx	3.4 Nm	1.1 Nm	5.1 Nm	1.7 Nm	6.8 Nm	2.3 Nm	8.5 Nm	2.8 Nm
Maximum moment My	4.5 Nm	1.4 Nm	6.8 Nm	2.3 Nm	9.0 Nm	2.8 Nm	11.3 Nm	4.0 Nm
Maximum moment Mz	3.4 Nm	1.1 Nm	5.1 Nm	1.7 Nm	6.8 Nm	2.3 Nm	8.5 Nm	2.8 Nm

† Capacities are per set of jaws and are not simultaneous

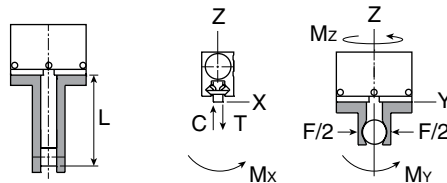

Dimensions: P5GU Clean Room Harsh Environment Series

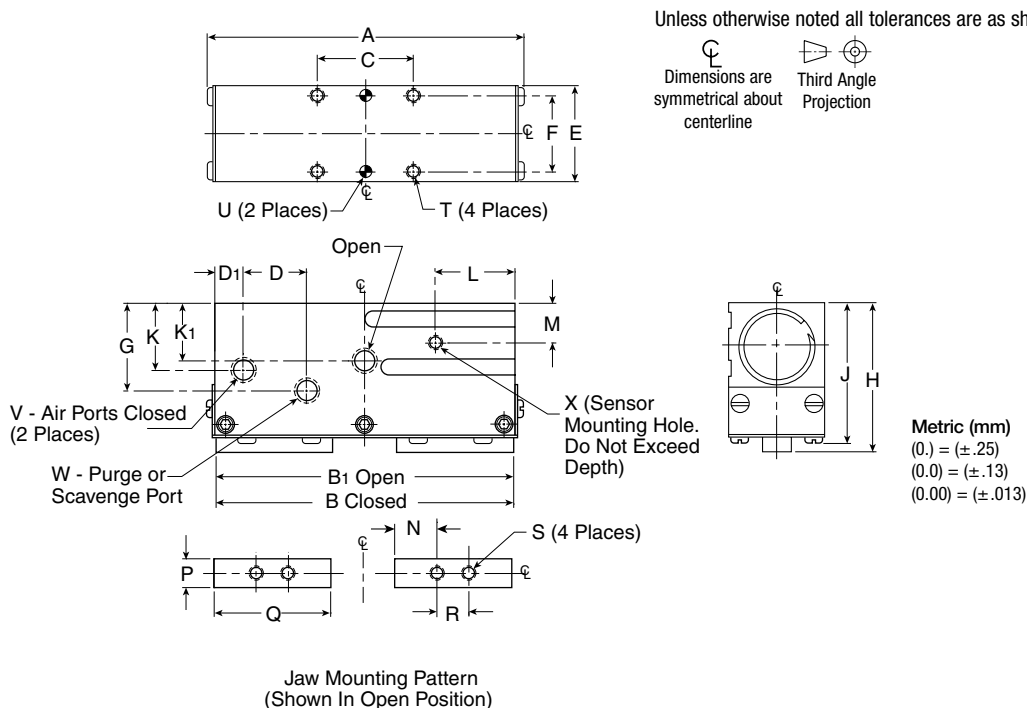

Part number	A	B	B ₁	C	D	D ₁	E	F	G	H	J	K	K ₁	L	M	N	P	Q	R
P5GU-011(006)	48.3	38	44	19.1	8	6	19.1	15.09	17	29.5	27.8	13	11	11	8	6.4	5.69 ^{+0.003} _{-0.003}	19.1	6.4
P5GU-011(013)	62.9	46	59	19.1	13	6	19.0	15.09	17	29.5	27.8	13	11	16	8	8.3	5.69 ^{+0.003} _{-0.003}	23.2	6.4
P5GU-013(019)	83.4	63	83	25.4	14	15	22.2	16.66	18	32.6	30.3	13	11	19	8	12.7	5.69 ^{+0.003} _{-0.003}	31.8	6.4
P5GU-013(025)	101.8	76	101	25.4	14	24	22.2	16.66	18	32.6	30.3	13	11	25	8	15.9	5.69 ^{+0.003} _{-0.003}	38.1	6.4

Part number	S	T	U	V	W	X
P5GU-011(006)	M3 x 4 Dp	M3 x 4 Dp	Ø 3 SF x 4 Dp	M5	M5	M3 x 3 Dp
P5GU-011(013)	M3 x 4 Dp	M3 x 4 Dp	Ø 3 SF x 4 Dp	M5	M5	M3 x 4 Dp
P5GU-013(019)	M3 x 4 Dp	M3 x 8 Dp	Ø 3 SF x 6 Dp	M5	M5	M3 x 4 Dp
P5GU-013(025)	M3 x 4 Dp	M3 x 8 Dp	Ø 3 SF x 6 Dp	M5	M5	M3 x 4 Dp

Dimensions in millimeters

- One piece lightweight aircraft quality aluminum body
- The body and bottom plate have hard-coat anodize 60 RC with PTFE impregnation
- 3 standard air port locations (front, back, and top)
- Back and top air ports can be o-ring manifold sealed to eliminate air lines
- Standard mounting slots for magneto resistive (sensors sold separately)
- Slip fit dowel pin holes in body and jaws
- Jaws are supported throughout the length of the body
- Purge / scavenge port used with vacuum for clean room environments or positive pressure with harsh environments
- Jaw components made from hardened and precision ground steel for minimum jaw play with hard plating for wear resistance and long life
- Front-to-back thru counterbores for socket head cap screw mounting
- Magnetic piston standard

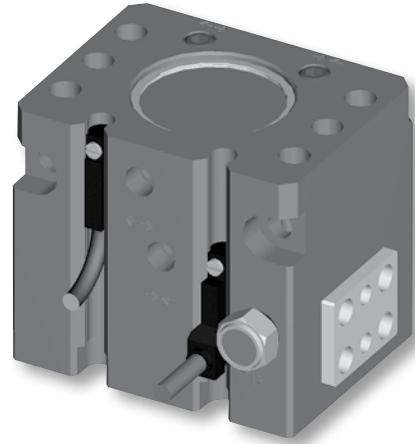

Operating information

Operating pressure:	1.5 to 7 bar (22 to 102 PSIG)
Temperature range:	
Nitrile seals (standard)	-35° to 80° C (-30° to 180° F)
Filtration requirements:	
Air filtration	40 micron or better
Air lubrication	Not necessary*
Air humidity	Low moisture content (dry)

*Addition of lubrication will greatly increase service life

Ordering Information: P5GN Compact Series

Function	Bore size (mm)	Ports (BSPP)	Stroke (mm)	Grip force @ 7 bar (N)	Accuracy +/- mm	Repeatability +/-mm	Weight (kg)	Part number
Double acting magnetic	12	M3	1.6	62	0.05	0.03	0.04	P5GN-012MSG001B
Double acting magnetic	12	M3	2.4	62	0.05	0.03	0.04	P5GN-012MSG002B
Double acting magnetic	12	M3	3.2	62	0.05	0.03	0.04	P5GN-012MSG003B
Double acting magnetic	14	M3	2.4	98	0.05	0.03	0.07	P5GN-014MSG002B
Double acting magnetic	14	M3	3.2	98	0.05	0.03	0.07	P5GN-014MSG003B
Double acting magnetic	14	M3	4.8	98	0.05	0.03	0.07	P5GN-014MSG005B
Double acting magnetic	22	M5	3.2	222	0.05	0.03	0.23	P5GN-022MSG003B
Double acting magnetic	22	M5	4.8	222	0.05	0.03	0.23	P5GN-022MSG005B
Double acting magnetic	22	M5	6.4	222	0.05	0.03	0.23	P5GN-022MSG006B
Double acting magnetic	32	M5	4.8	445	0.08	0.03	0.46	P5GN-032MSG005B
Double acting magnetic	32	M5	6.4	445	0.08	0.03	0.46	P5GN-032MSG006B
Double acting magnetic	32	M5	9.5	445	0.08	0.03	0.46	P5GN-032MSG010B

Sensor part numbers: Page 53.

Most popular.

Loading information - P5GN-012

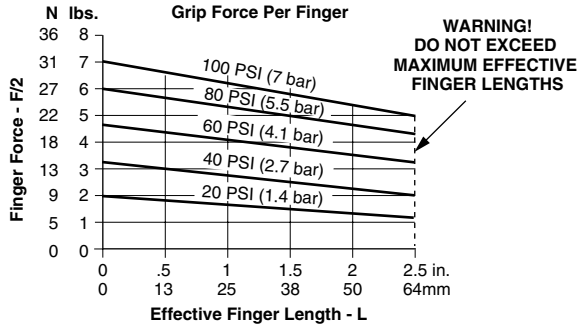

Loading information - P5GN-022

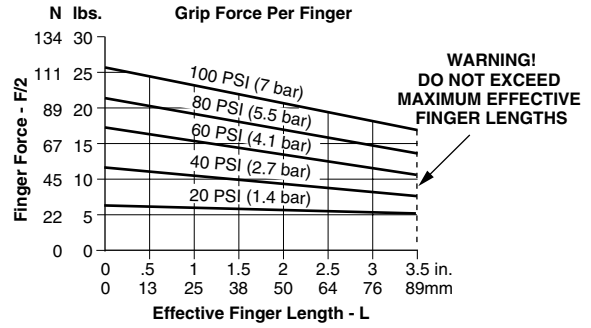

Loading information - P5GN-014

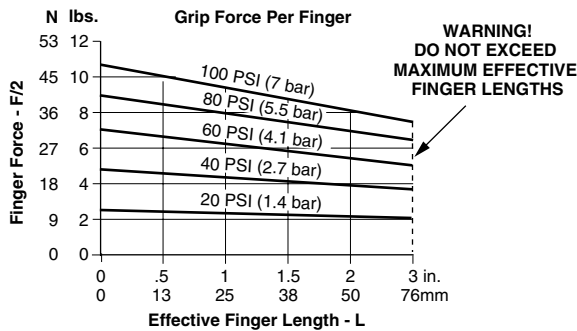

Loading information - P5GN-032

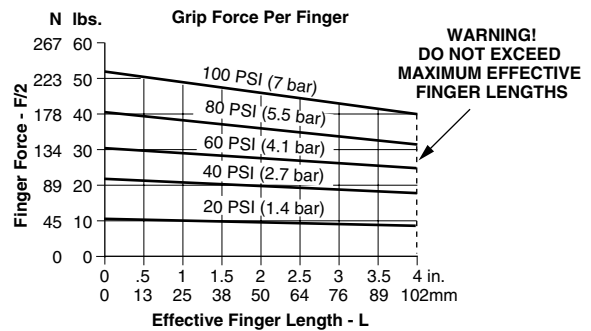

Loading capacity† - P5GN Compact Series

	P5GN-012		P5GN-014		P5GN-022		P5GN-032	
	Static (metric)	Dynamic (metric)	Static (metric)	Dynamic (metric)	Static (metric)	Dynamic (metric)	Static (metric)	Dynamic (metric)
Maximum tensile T	134 N	27 N	267 N	45 N	614 N	111 N	2225 N	289 N
Maximum compressive C	223 N	45 N	401 N	67 N	1224 N	111 N	4228 N	289 N
Maximum moment Mx	2 Nm	0.6 Nm	5 Nm	8 Nm	14 Nm	2 Nm	48 Nm	8 Nm
Maximum moment My	2 Nm	0.6 Nm	5 Nm	8 Nm	14 Nm	2 Nm	48 Nm	8 Nm
Maximum moment Mz	2 Nm	0.6 Nm	5 Nm	8 Nm	14 Nm	2 Nm	48 Nm	8 Nm

† Capacities are per set of jaws and are not simultaneous

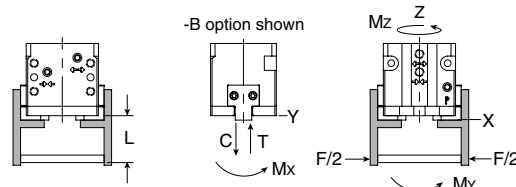

Dimensions: P5GN Compact Series

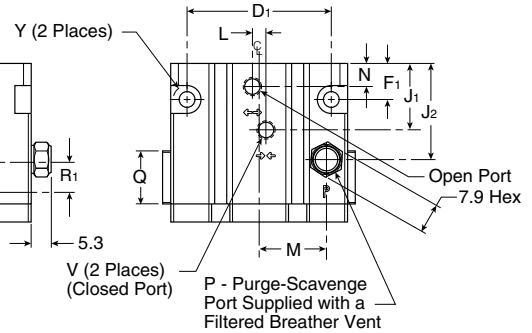
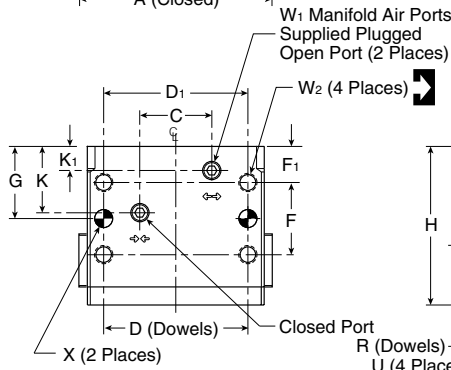
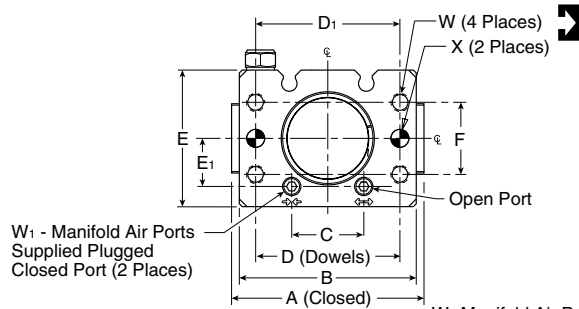

Unless otherwise noted all tolerances are as shown below

Dimensions are symmetrical about centerline Third Angle Projection Metric (mm)

 (0.) = (±.25)

 (0.0) = (±.13)

 (0.00) = (±.013)

Part number	A	B	C	D	D ₁	E	E ₁	F	F ₁	G	H	J	J ₁	J ₂	K	K ₁	L	M	N	P
P5GN-012	28	24.4	10.2	19.05	19.1	22.2	7.9	9.5	6.7	11.4	24.4	17.6	9.7	14.7	9.7	3.6	-	9.4	3.6	M3 x 3 Dp
P5GN-014	35	31.2	10.2	19.05	19.1	24.1	8.6	9.5	8.0	12.7	27.4	19.9	11.2	17.0	11.2	3.6	-	11.7	3.6	M3 x 3 Dp
P5GN-022	51	46.7	19.1	38.10	38.1	36.1	12.7	19.1	9.5	19.1	41.9	26.1	17.5	25.4	17.5	6.1	3.6	17.8	6.1	M5 x 4 Dp
P5GN-032	64	59.7	22.9	38.10	38.1	43.2	16.5	19.1	12.7	22.2	51.2	31.3	19.8	30.5	19.8	6.4	4.1	22.4	6.4	M5 x 4 Dp

Part number	Q	R	R ₁	S	T	U	V	W	W ₁	W ₂	X	Y	Z
P5GN-012	7.11 ^{+0.00} _{-0.003}	3.81	-	10.67 ^{+0.00} _{-0.003}	6.4	∅ 2.0 H7 x 3 Dp	M3 x 3 Dp	M3 x 4 Dp	M3 x 3 Dp	M3 x 4 Dp	∅ 3 H7 x 3 Dp	∅ 5 x 4 Dp C'bore (for M2.5 SHCS)	M3 x 4 Dp (4 Places)
P5GN-014	8.64 ^{+0.00} _{-0.003}	4.76	-	12.19 ^{+0.00} _{-0.003}	7.1	∅ 2.5 H7 x 3 Dp	M3 x 3 Dp	M3 x 4 Dp	M3 x 3 Dp	M3 x 4 Dp	∅ 3 H7 x 3 Dp	∅ 5 x 3 Dp C'bore (for M2.5 SHCS)	M4 x 5 Dp (4 Places)
P5GN-022	13.97 ^{+0.00} _{-0.003}	7.94	8.0	18.29 ^{+0.00} _{-0.003}	11.4	∅ 3 H7 x 5 Dp	M5 x 4 Dp	M5 x 8 Dp	M5 x 5 Dp	M5 x 6 Dp	∅ 5 H7 x 5 Dp	∅ 7 x 4 Dp C'bore (for M4 SHCS)	M4 x 6 Dp (8 Places)
P5GN-032	19.05 ^{+0.00} _{-0.003}	11.11	11.1	25.40 ^{+0.00} _{-0.003}	15.9	∅ 4 H7 x 6 Dp	M5 x 4 Dp	M5 x 8 Dp	M5 x 5 Dp	M5 x 6 Dp	∅ 5 H7 x 6 Dp	∅ 7 x 4 Dp C'bore (for M4 SHCS)	M5 x 8 Dp (8 Places)

Dimensions in millimeters

- One piece lightweight aircraft quality aluminum body
- The body and bottom plate have hard-coat anodize 60 RC with PTFE impregnation
- 3 standard air port locations (front, back, and top)
- Back and top air ports can be o-ring manifold sealed to eliminate air lines
- Standard mounting slots for magneto resistive (sensors sold separately)
- Slip fit dowel pin holes in body and jaws
- Jaws are supported throughout the length of the body
- Purge / scavenge port used with vacuum for clean room environments or positive pressure with harsh environments
- Jaw components made from hardened and precision ground steel for minimum jaw play with hard plating for wear resistance and long life
- Front-to-back thru counterbores for socket head cap screw mounting
- Magnetic piston standard

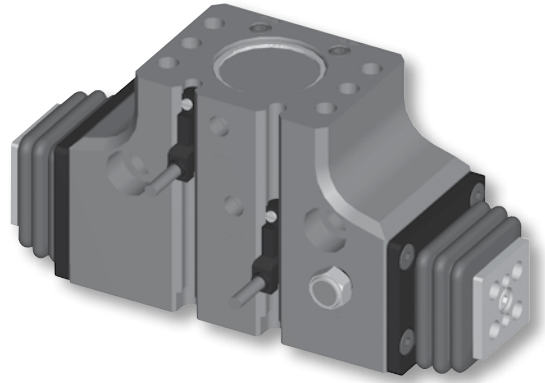

Operating information

Operating pressure:	1.5 to 7 bar (22 to 102 PSIG)
Temperature range:	
Nitrile seals (standard)	-35° to 80° C (-30° to 180° F)
Filtration requirements:	
Air filtration	40 micron or better
Air lubrication	Not necessary*
Air humidity	Low moisture content (dry)

*Addition of lubrication will greatly increase service life

Ordering Information: P5GM Parallel Series

Function	Bore size (mm)	Ports (BSPP)	Stroke (mm)	Grip force @ 7 bar (N)	Accuracy +/- mm	Repeatability +/-mm	Weight (kg)	Part number
Double acting magnetic	10	M3	4.8	62	0.05	0.03	0.04	P5GM-010MSG005B
Double acting magnetic	10	M3	6.4	62	0.05	0.03	0.04	P5GM-010MSG006B
Double acting magnetic	10	M3	9.5	62	0.05	0.03	0.04	P5GM-010MSG010B
Double acting magnetic	14	M3	6.4	98	0.05	0.03	0.14	P5GM-014MSG006B
Double acting magnetic	14	M3	9.5	98	0.05	0.03	0.14	P5GM-014MSG010B
Double acting magnetic	14	M3	12.7	98	0.05	0.03	0.14	P5GM-014MSG013B
Double acting magnetic	22	M5	9.5	222	0.05	0.03	0.43	P5GM-022MSG010B
Double acting magnetic	22	M5	12.7	222	0.05	0.03	0.43	P5GM-022MSG013B
Double acting magnetic	22	M5	19.1	222	0.05	0.03	0.43	P5GM-022MSG019B
Double acting magnetic	32	M5	12.7	445	0.08	0.03	0.90	P5GM-032MSG013B
Double acting magnetic	32	M5	19.1	445	0.08	0.03	0.90	P5GM-032MSG019B
Double acting magnetic	32	M5	25.4	445	0.08	0.03	0.90	P5GM-032MSG032B

Sensor part numbers: Page 53.

Most popular.

Loading information - P5GM-010

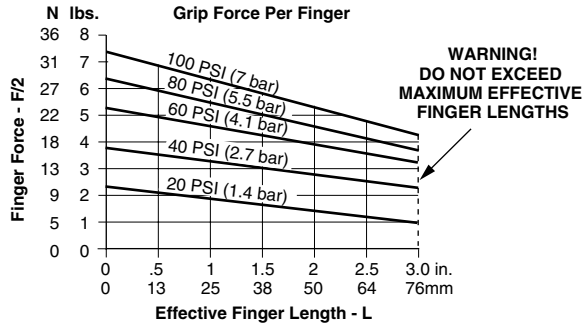

Loading information - P5GM-022

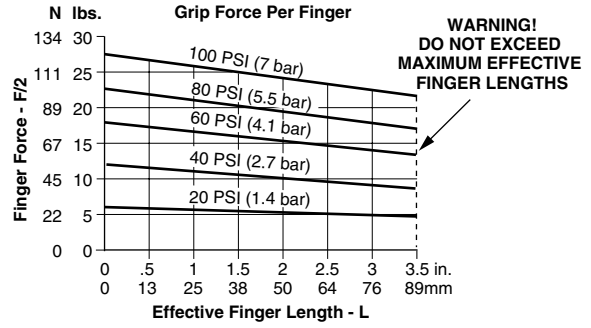

Loading information - P5GM-014

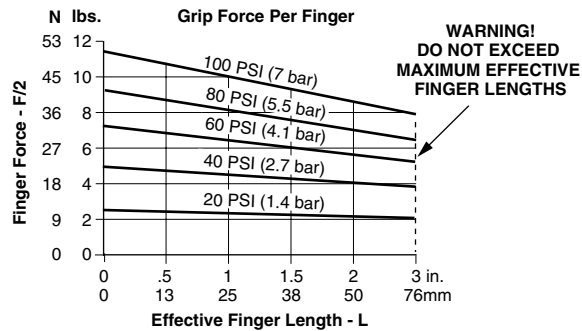

Loading information - P5GM-032

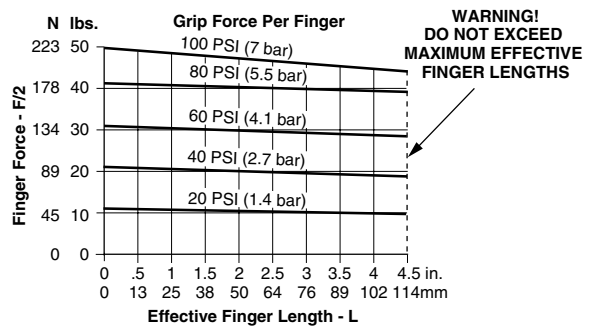

Loading capacity† - P5GM Parallel Series

	P5GM-010		P5GM-014		P5GM-022		P5GM-032	
	Static (metric)	Dynamic (metric)	Static (metric)	Dynamic (metric)	Static (metric)	Dynamic (metric)	Static (metric)	Dynamic (metric)
Maximum tensile T	445 N	67 N	556 N	111 N	1558 N	178 N	3004 N	401 N
Maximum compressive C	668 N	111 N	1113 N	111 N	2893 N	178 N	5785 N	401 N
Maximum moment Mx	10 Nm	2 Nm	13 Nm	2 Nm	28 Nm	5 Nm	73 Nm	12 Nm
Maximum moment My	10 Nm	2 Nm	13 Nm	2 Nm	28 Nm	5 Nm	73 Nm	12 Nm
Maximum moment Mz	10 Nm	2 Nm	13 Nm	2 Nm	28 Nm	5 Nm	73 Nm	12 Nm

† Capacities are per set of jaws and are not simultaneous

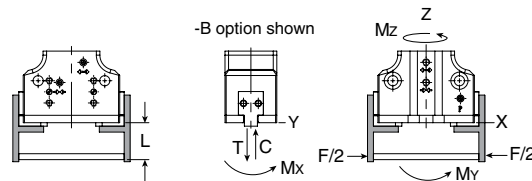

Dimensions: P5GM Parallel Series

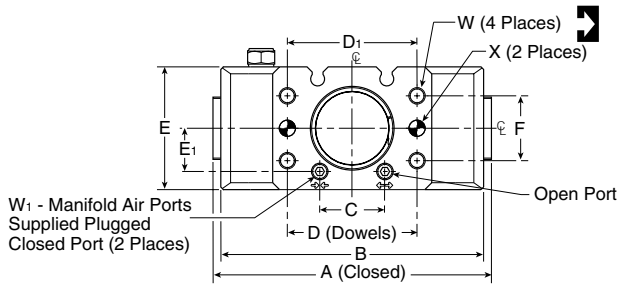

Unless otherwise noted all tolerances are as shown below

Dimensions are symmetrical about centerline
 Third Angle Projection
Metric (mm)
 (0.) = (±.25)
 (0.0) = (±.13)
 (0.00) = (±.013)

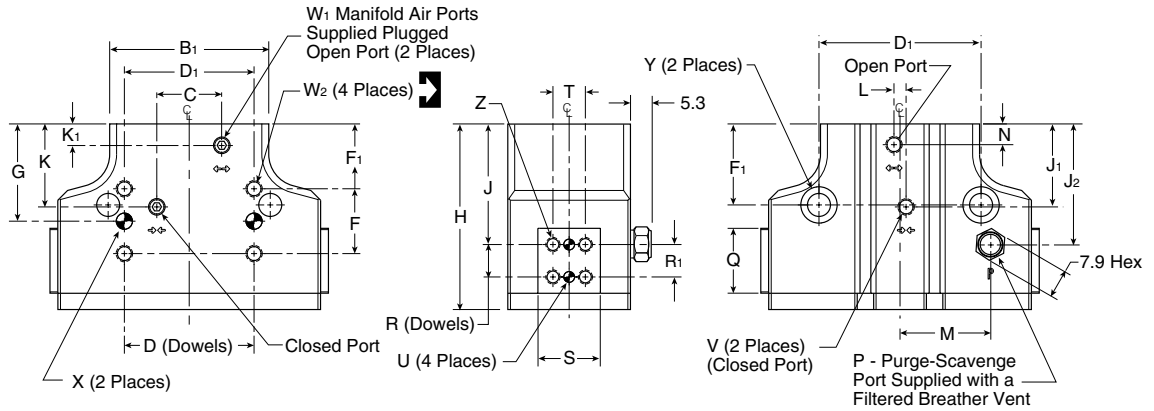

Part number	A	B	B ₁	C	D	D ₁	E	E ₁	F	F ₁	G	H	J	J ₁	J ₂	K	K ₁	L	M	N	P
P5GM-010	45	41.4	24.4	10.2	19.05	19.1	22.2	7.9	9.5	12.7	17.5	30.7	22.4	13.5	20.3	13.5	3.6	-	14.7	3.6	M3 x 3 Dp
P5GM-014	56	52.6	31.2	10.2	19.05	19.1	24.1	8.6	9.5	15.8	20.6	36.2	26.6	15.7	23.4	15.7	3.6	-	17.3	3.6	M3 x 3 Dp
P5GM-022	82	77.2	46.7	19.1	38.10	38.1	36.1	12.7	19.1	19.1	28.6	54.5	35.4	24.4	35.6	24.4	6.1	3.6	26.7	6.1	M5 x 4 Dp
P5GM-032	103	98.8	59.7	22.9	38.10	38.1	43.2	16.5	19.1	28.6	38.1	67.0	41.6	29.2	43.2	29.2	6.4	4.1	35.1	6.4	M5 x 4 Dp

Part number	Q	R	R ₁	S	T	U	V	W	W ₁	W ₂	X	Y	Z
P5GM-010	10.67 ^{+0.003} _{-0.003}	4.76	-	10.67 ^{+0.003} _{-0.003}	6.4	∅ 2.0 H7 x 3 Dp	M3 x 3 Dp	M3 x 4 Dp	M3 x 3 Dp	M3 x 4 Dp	∅ 3 H7 x 3 Dp	∅ 7 x 4 Dp C'bore (for M4 SHCS)	M3 x 4 Dp (4 Places)
P5GM-014	12.70 ^{+0.003} _{-0.003}	4.76	-	12.19 ^{+0.003} _{-0.003}	7.1	∅ 2.5 H7 x 3 Dp	M3 x 3 Dp	M3 x 4 Dp	M3 x 3 Dp	M3 x 4 Dp	∅ 3 H7 x 3 Dp	∅ 7 x 4 Dp C'bore (for M4 SHCS)	M4 x 5 Dp (4 Places)
P5GM-022	19.05 ^{+0.003} _{-0.003}	9.53	9.5	18.29 ^{+0.003} _{-0.003}	9.5	∅ 3 H7 x 5 Dp	M5 x 3Dp	M5 x 8 Dp	M5 x 5 Dp	M5 x 6 Dp	∅ 5 H7 x 5 Dp	∅ 11 x 7 Dp C'bore (for M6 SHCS)	M4 x 6 Dp (8 Places)
P5GM-032	25.40 ^{+0.003} _{-0.003}	15.88	15.9	25.40 ^{+0.003} _{-0.003}	15.9	∅ 4 H7 x 6 Dp	M5 x 4 Dp	M5 x 8 Dp	M5 x 5 Dp	M5 x 6 Dp	∅ 5 H7 x 5 Dp	∅ 11 x 7 Dp C'bore (for M6 SHCS)	M5 x 8 Dp (8 Places)

Dimensions in millimeters

- C-bores on inside of jaws for thru mounting to increase range of applications
- Standard sensor mounting slots for magneto resistive and inductive sensors (sensors sold separately)
- End of stroke cushions reduce shock of fully open and close strokes
- Each jaw is supported by 2 shafts that extend the entire length of the body and are guided by 2 oil impregnated bronze bushings per shaft
- Hardened precision stainless steel shafting for wear resistance and long life
- Magneto resistive sensors are an alternative option to inductive sensors (magnets supplied standard)
- Top air ports can be o-ring manifold sealed to eliminate air lines
- 2 standard air port locations (front and top)
- Slip fit dowel pin holes in body and jaws
- Large jaw configuration allows for simplified finger mounting

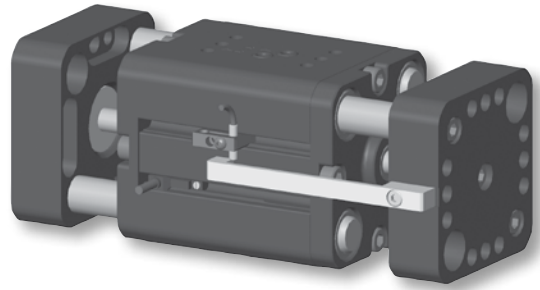

Operating information

Operating pressure:	3 to 7 bar (44 to 102 PSIG)
Temperature range:	
Nitrile seals (Standard)	-35° to 80° C (-30° to 180° F)
Filtration requirements:	
Air filtration	40 micron or better
Air lubrication	Not necessary*
Air humidity	Low moisture content (dry)
*Addition of lubrication will greatly increase service life	

Ordering Information: P5GS Wide Body Series

Function	Bore size (mm)	Ports (BSPP)	Stroke (mm)	Grip force @ 7 bar (N)	Accuracy +/- mm	Repeatability +/-mm	Weight (kg)	Part number
Double acting magnetic	16	M3	19.1	222	0.08	0.03	0.30	P5GS-016MSG019B
Double acting magnetic	16	M3	31.8	222	0.08	0.03	0.39	P5GS-016MSG032B
Double acting magnetic	24	M5	25.4	445	0.08	0.03	0.81	P5GS-024MSG025B
Double acting magnetic	24	M5	50.8	445	0.08	0.03	1.20	P5GS-024MSG051B
Double acting magnetic	32	M5	38.1	800	0.08	0.03	1.48	P5GS-032MSG038B
Double acting magnetic	32	M5	73.5	800	0.08	0.03	2.0	P5GS-032MSG074B

Sensor part numbers: Page 53.

Most popular.

Loading information - P5GS-016MSG019B

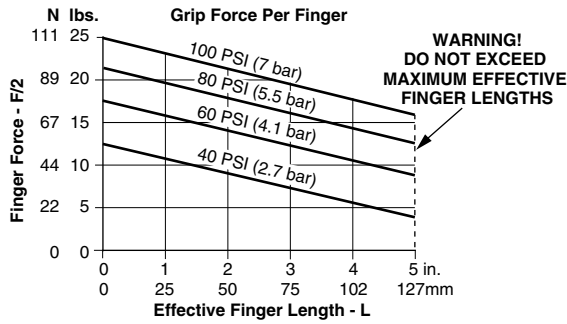

Loading information - P5GS-024MSG051B

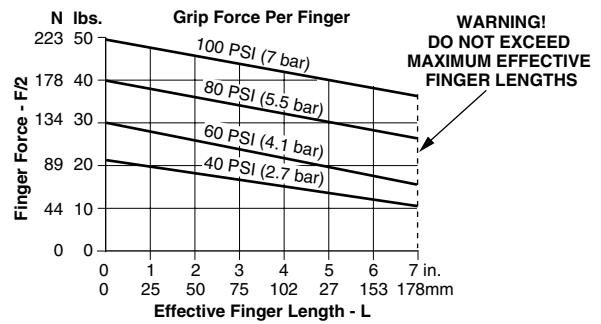

Loading information - P5GS-016MSG032B

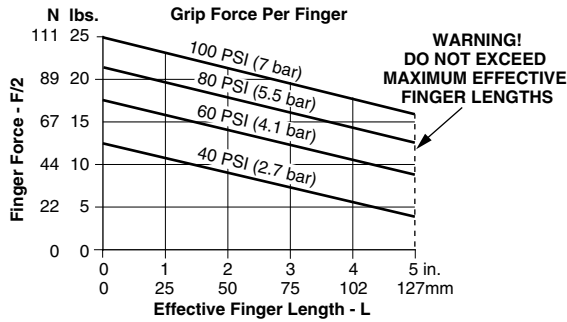

Loading information - P5GS-032MSG038B

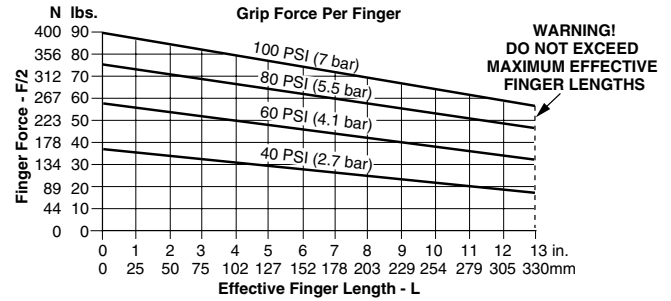

Loading information - P5GS-024MSG025B

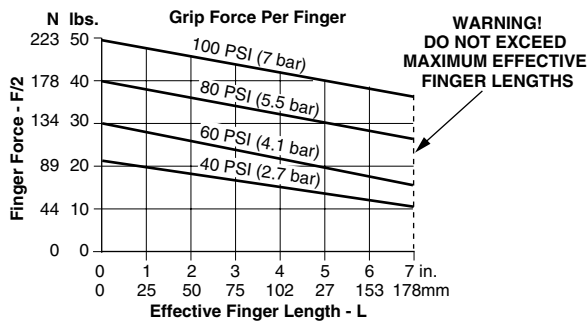

Loading information - P5GS-032MSG074B

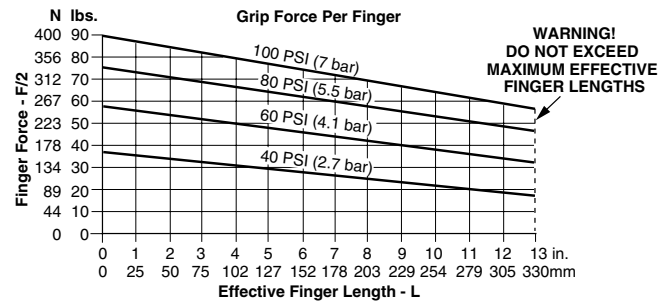

Loading capacity† - P5GS Wide Body Series

	P5GS-016M***19B		P5GS-016M***32B		P5GS-024M***25B		P5GS-024M***51B		P5GS-032M***38B		P5GS-032M***74B	
	Static (metric)	Dynamic (metric)	Static (metric)	Dynamic (metric)	Static (metric)	Dynamic (metric)	Static (metric)	Dynamic (metric)	Static (metric)	Dynamic (metric)	Static (metric)	Dynamic (metric)
Maximum tensile T	267 N	53 N	267 N	53 N	534 N	107 N	534 N	107 N	2668 N	267 N	2668 N	267 N
Maximum compressive C	267 N	53 N	267 N	53 N	534 N	107 N	534 N	107 N	2668 N	267 N	2668 N	267 N
Maximum moment Mx	14 Nm	3 Nm	14 Nm	3 Nm	24 Nm	5 Nm	24 Nm	5 Nm	68 Nm	7 Nm	68 Nm	7 Nm
Maximum moment My	20 Nm	4 Nm	20 Nm	4 Nm	34 Nm	7 Nm	34 Nm	7 Nm	102 Nm	10 Nm	102 Nm	10 Nm
Maximum moment Mz	14 Nm	3 Nm	14 Nm	3 Nm	24 Nm	5 Nm	24 Nm	5 Nm	68 Nm	7 Nm	68 Nm	7 Nm

† Capacities are per set of jaws and are not simultaneous

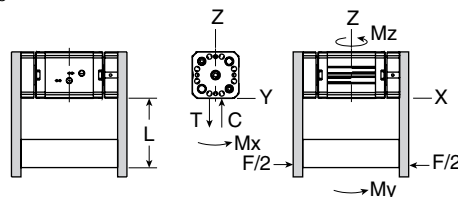

Dimensions: P5GS Wide Body Series

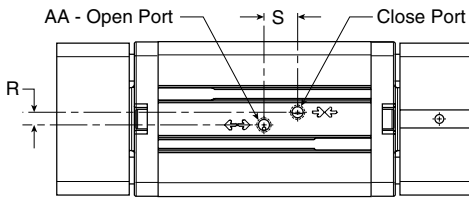
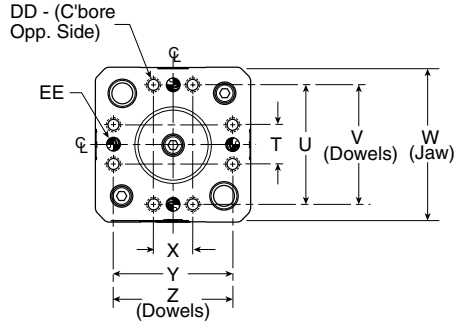
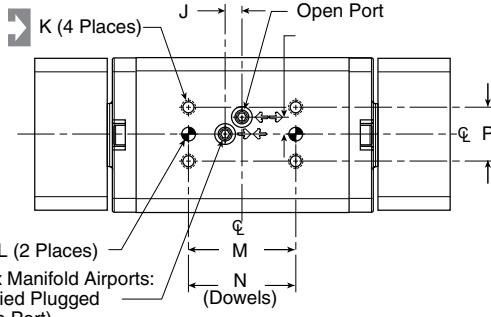
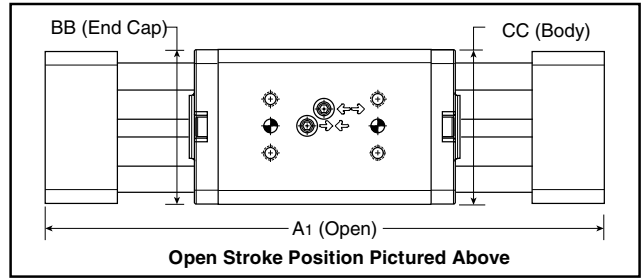
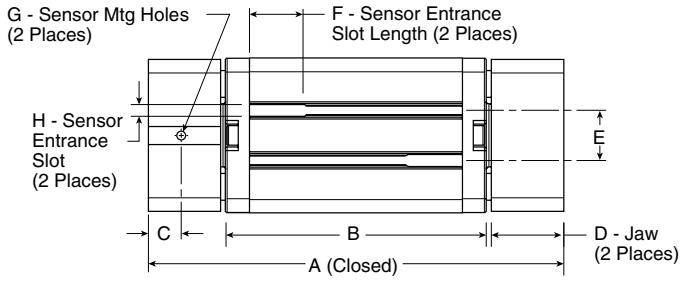

Unless otherwise noted all tolerances are as shown below

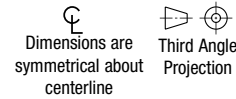

Metric (mm)
(0.) = (±.25)
(0.0) = (±.13)
(0.00) = (±.013)

Part number	A	A ₁	B	C	D	E	F	G	H	J	K	L	M	N	P	Q
P5GS-016MSG019B	79	98	54.4	5.8	10.5	7.9	19.1	M3 x 3 Dp	4.2	4	M3 x 5 Dp	∅ 3h7 x 5 Dp	19.0	19.05	9.5	M3 x 5 Dp
P5GS-016MSG032B	104	136	67.1	7.3	16.9	7.9	19.1	M3 x 3 Dp	4.2	4	M3 x 5 Dp	∅ 3h7 x 5 Dp	19.1	19.05	9.5	M3 x 5 Dp
P5GS-024MSG025B	97	122	67.1	6.7	13.0	17.8	19.1	M3 x 4 Dp	4.2	6	M3 x 7 Dp	∅ 5h7 x 5 Dp	38.1	38.10	19.1	M5 x 7 Dp
P5GS-024MSG051B	147	198	92.5	11.7	25.7	17.8	19.1	M3 x 4 Dp	4.2	6	M3 x 7 Dp	∅ 5h7 x 5 Dp	38.1	38.10	19.1	M5 x 7 Dp
P5GS-032MSG038B	125	164	82.8	12.1	19.2	18.8	19.1	M3 x 4 Dp	4.2	6	M3 x 8 Dp	∅ 5h7 x 5 Dp	38.1	38.10	19.1	M5 x 5 Dp
P5GS-032MSG074B	177	240	108.2	14.9	39.1	18.8	19.1	M3 x 4 Dp	4.2	6	M3 x 8 Dp	∅ 5h7 x 5 Dp	38.1	38.10	19.1	M5 x 7 Dp

Part number	R	S	T	U	V	W	X	Y	Z	AA	BB	CC	DD	EE
P5GS-016MSG019B	6	10	10.0	30.0	30.00	37.6	10.0	30.0	30.00	M5 x 5 Dp	37.6	38.0	M4 x 8 Dp	∅ 4h7 x 5 Dp
P5GS-016MSG032B	6	12	10.0	30.0	30.00	37.6	10.0	30.0	30.00	M5 x 5 Dp	37.6	38.0	M4 x 8 Dp	∅ 4h7 x 5 Dp
P5GS-024MSG025B	5	11	14.0	42.5	42.50	54.0	14.0	42.5	42.50	M5 x 6 Dp	54.7	55.0	M5 x 10 Dp	∅ 5h7 x 5 Dp
P5GS-024MSG051B	5	12	14.0	42.5	42.50	54.0	14.0	42.5	42.50	M5 x 6 Dp	54.7	55.0	M5 x 10 Dp	∅ 5h7 x 5 Dp
P5GS-032MSG038B	5	15	18.0	51.0	51.00	63.0	18.0	51.0	51.00	M5 x 6 Dp	63.7	64.0	M6 x 13 Dp	∅ 6h7 x 8 Dp
P5GS-032MSG074B	5	15	18.0	51.0	51.00	63.0	18.0	51.0	51.00	M5 x 6 Dp	63.7	64.0	M6 x 13 Dp	∅ 6h7 x 8 Dp

Dimensions in millimeters

- Extremely compact and robust package
- One piece 7075 -T6 aircraft quality aluminum body
- Dynamic components are hardened for wear resistance and long life
- Accessory mounting holes mount sensors to unit
- Slip fit dowel pin holes in body and jaws
- Jaws are supported throughout the length of the body and are precision ground for minimal jaw play
- A double acting piston is connected by a shaft to a double sided wedge
- The wedge slides in a slot located in each of the jaws converting vertical motion of the wedge into horizontal synchronous motion of the jaws
- The large surface area of the wedge minimizes frictional wear
- Magnetic piston standard



Operating information

Operating pressure:	3 to 7 bar (44 to 102 PSIG)
Temperature range:	
Nitrile seals (standard)	-35° to 80° C (-30° to 180° F)
Fluorocarbon seals (optional)	-30° to 150° C (-20° to 300° F)
Filtration requirements:	
Air filtration	40 micron or better
Air lubrication	Not necessary*
Air humidity	Low moisture content (dry)

*Addition of lubrication will greatly increase service life

Ordering Information: P5GT Double Wedge Series

Function	Bore size (mm)	Ports (BSPP)	Stroke (mm)	Grip force @ 7 bar (N)	Accuracy +/- mm	Repeatability +/-mm	Weight (kg)	Part number
Double acting magnetic, Nitrile	25	M5	6.4	178	0.05	0.03	0.12	P5GT-025MSG006B
Double acting magnetic, Fluorocarbon	25	M5	6.4	178	0.05	0.03	0.12	P5GT-025MFG006B
Double acting magnetic, Nitrile	25	M5	9.5	178	0.05	0.03	0.25	P5GT-025MSG010B
Double acting magnetic, Fluorocarbon	25	M5	9.5	178	0.05	0.03	0.25	P5GT-025MFG010B
Double acting magnetic, Nitrile	32	M5	12.7	311	0.05	0.03	0.57	P5GT-032MSG013B
Double acting magnetic, Fluorocarbon	32	M5	12.7	311	0.05	0.03	0.57	P5GT-032MFG013B
Double acting magnetic, Nitrile	46	1/8	19.1	979	0.08	0.03	1.0	P5GT-046MSG019B
Double acting magnetic, Fluorocarbon	46	1/8	19.1	979	0.08	0.03	1.0	P5GT-046MFG019B
Double acting magnetic, Nitrile	64	1/8	31.8	1779	0.08	0.03	3.5	P5GT-064MSG032B
Double acting magnetic, Fluorocarbon	64	1/8	31.8	1779	0.08	0.03	3.5	P5GT-064MFG032B
Double acting magnetic, Nitrile	89	1/4	50.8	2669	0.08	0.03	9.5	P5GT-089MSG051B
Double acting magnetic, Fluorocarbon	89	1/4	50.8	2669	0.08	0.03	9.5	P5GT-089MFG051B

Sensor part numbers: Page 53.

Most popular.

Loading information - P5GT-025/006

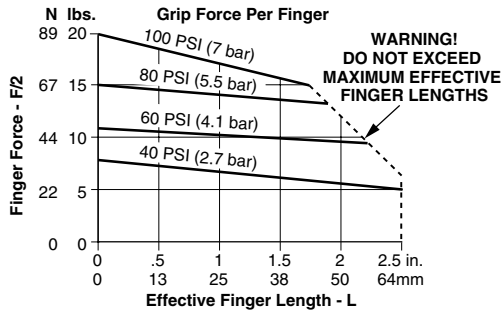

Loading information - P5GT-046

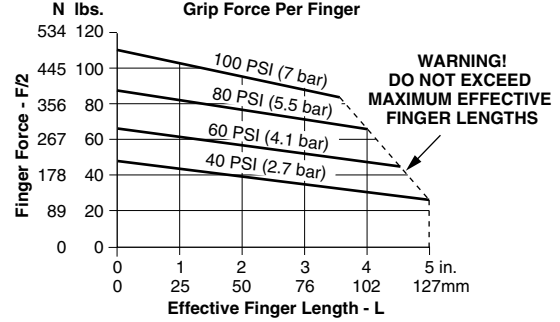

Loading information - P5GT-025/010

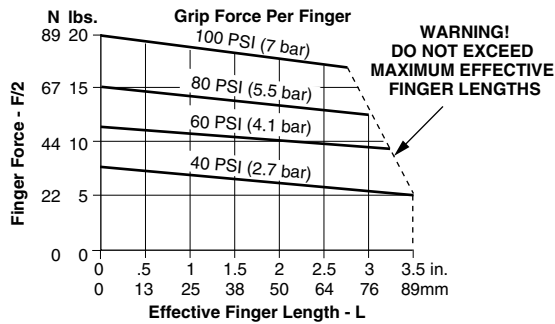

Loading information - P5GT-064

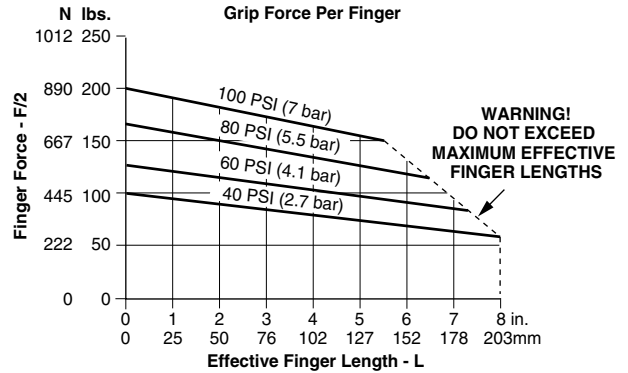

Loading information - P5GT-032

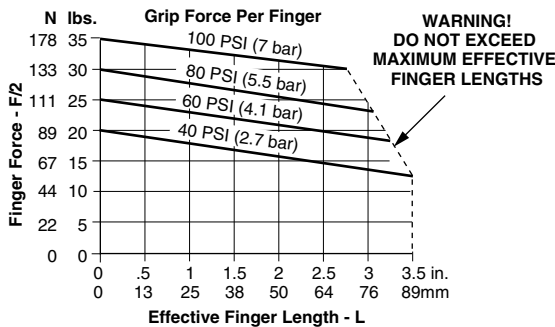

Loading information - P5GT-089

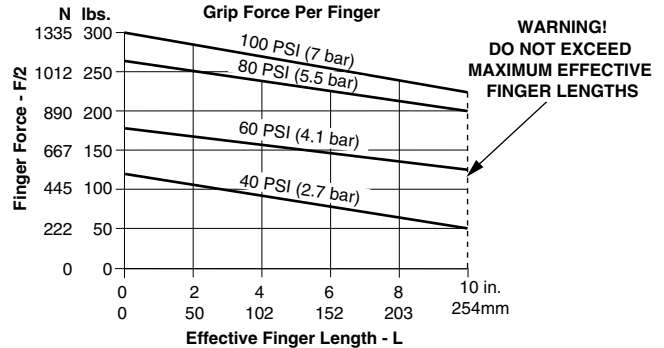

Loading capacity† - P5GT Double Wedge Series

	P5GT-025(006)		P5GT-025(010)		P5GT-032		P5GT-046		P5GT-064		P5GT-089	
	Static (metric)	Dynamic (metric)	Static (metric)	Dynamic (metric)	Static (metric)	Dynamic (metric)	Static (metric)	Dynamic (metric)	Static (metric)	Dynamic (metric)	Static (metric)	Dynamic (metric)
Maximum tensile T	445 N	111 N	890 N	111 N	1779 N	222 N	3336 N	445 N	6672 N	1112 N	13345 N	1334 N
Maximum compressive C	890 N	111 N	1779 N	111 N	3336 N	222 N	6672 N	445 N	13345 N	1112 N	26689 N	1334 N
Maximum moment Mx	11 Nm	2 Nm	17 Nm	3 Nm	34 Nm	6 Nm	85 Nm	14 Nm	170 Nm	28 Nm	565 Nm	56 Nm
Maximum moment My	11 Nm	2 Nm	17 Nm	3 Nm	34 Nm	6 Nm	85 Nm	14 Nm	170 Nm	28 Nm	565 Nm	56 Nm
Maximum moment Mz	11 Nm	2 Nm	17 Nm	3 Nm	34 Nm	6 Nm	85 Nm	14 Nm	170 Nm	28 Nm	565 Nm	56 Nm

† Capacities are per set of jaws and are not simultaneous

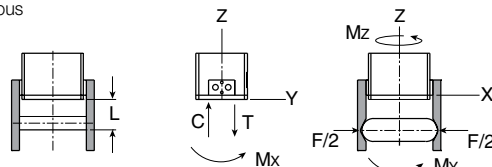

Dimensions: P5GT Double Wedge Series

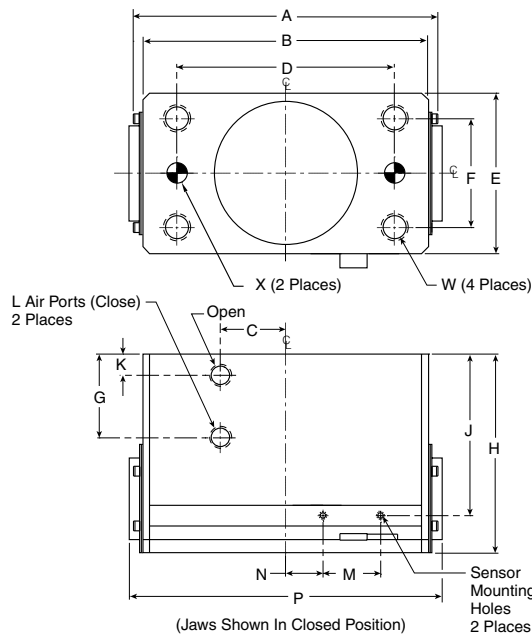

Unless otherwise noted all tolerances are as shown below

Dimensions are symmetrical about centerline
Third Angle Projection

Metric (mm)
(0.) = (±.25)
(0.0) = (±.13)
(0.00) = (±.013)

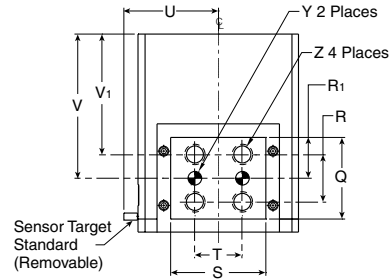

Part number	A	B	C	D	E	F	G	H	J	K	L	M	N	P	Q
P5GT-025(006)	–	38.1	20	31.75	31.8	12.70	17	28.6	9	5	M5	25	–	Open 48 Closed 41	9.55 ^{+0.00} / _{-.003}
P5GT-025(010)	–	50.8	23	38.10	38.1	25.40	12	35.6	14	9	M5	14	6	Open 63 Closed 54	12.34 ^{+0.00} / _{-.003}
P5GT-032	70.4	63.50	30	50.80	41.3	19.05	14.4	47.3	18	7	M5	17	3	Open 81 Closed 68	18.69 ^{+0.00} / _{-.003}
P5GT-046	89.6	82.55	25	63.50	54.0	25.40	25	61.9	46	8	G1/8	27	5	Open 108 Closed 85	25.43 ^{+0.00} / _{-.003}
P5GT-064	142.2	133.35	–	101.60	74.9	50.8	39	92.8	75	10	G1/8	27	17	Open 177 Closed 146	38.10 ^{+0.00} / _{-.003}
P5GT-089	214.7	203.20	–	152.40	100.3	69.9	47	118.2	98	11	G1/4	56	25	Open 266 Closed 216	47.63 ^{+0.00} / _{-.003}

Part number	R	S	T	U	V	W	X	Y	Z	Z1
P5GT-025(006)	6.35	15.88 ^{+0.00} / _{-.003}	7.9	22.2	21.5	M4 x 9 Dp	Ø 3H7 x 6 Dp	Ø 2H7 x 4 Dp	M4 x 4.7 Dp	M3 x 4 Dp
P5GT-025(010)	7.95	18.67 ^{+0.00} / _{-.003}	12.7	25.4	26.3	M6 x 12 Dp	Ø 5H7 x 6 Dp	Ø 2.5H7 x 4 Dp	M4 x 7 Dp	M3 x 4 Dp
P5GT-032	9.53	25.01 ^{+0.00} / _{-.003}	17.5	27.0	28.5	M6 x 12 Dp	Ø 5H7 x 6 Dp	Ø 4H7 x 4 Dp	M5 x 9 Dp	M3 x 4 Dp
P5GT-046	12.70	31.78 ^{+0.00} / _{-.003}	19.1	33.3	38.1	M10 x 19 Dp	Ø 6H7 x 12 Dp	Ø 5H7 x 9 Dp	M6 x 12 Dp	M3 x 6 Dp
P5GT-064	22.2	44.48 ^{+0.00} / _{-.003}	22.23	44.2	67.4	M12 x 25 Dp	Ø 10H8 x 12 Dp	Ø 8H7 x 12 Dp	M10 x 19 Dp	M3 x 9 Dp
P5GT-089	28.57	57.10 ^{+0.00} / _{-.003}	34.9	56.9	70.7	M20 x 38 Dp	Ø 12H8 x 19 Dp	Ø 6H7 x 12 Dp	M12 x 28 Dp	M3 x 9 Dp

Dimensions in millimeters

- One piece, lightweight aircraft quality aluminum body ensures product accuracy
- The body and jaws are hard-coat anodized to 60 RC with PTFE impregnation
- Ridged design and full body support of the jaws allows for long finger lengths
- Versatile mounting on top, side front and back of body.
- IP54 rating for tough application environments
- Slip fit dowel pin holes located in body and jaws for precision mounting
- Precision rack and pinion drive components for smooth actuation. Zero backlash while gripping ensures excellent repeatability and accuracy.
- Built in electronics, no external control board needed
- Magnetic piston standard

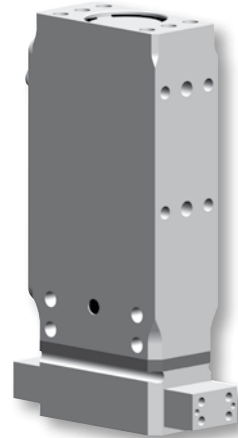

Operating information

Voltage:	24VDC
Power Req. @ 100% Duty Cycle:	4.2 Watts
Current - Peak:	1.5 Amps Max.
Current - Continuous:	0.175 Amps
Temperature range:	5° to 60° C (41° to 140° F)

Ordering Information: P5GP Electric Gripper Series

Function	Stroke (mm)	Grip force (N)	Accuracy +/- mm	Repeatability +/-mm	Weight (kg)	Part number
Electric	25	111	0.051	0.025	0.53	P5GP-000ESX025B

Sensor part numbers: Page 53.

Electrical Interface

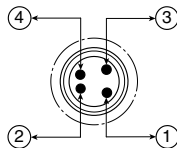

Pin Out (Looking Into Header Connector On Gripper)

- 1 Brown (+ 24 VDC)
- 2 White (Open Gripper) +24 VDC = Active
- 3 Blue (Ground)
- 4 Black (Close Gripper) +24 VDC = Active

4-Wire Power & Signal Cable: P8S-CABL-046

Most popular.

Loading information - P5GP-000

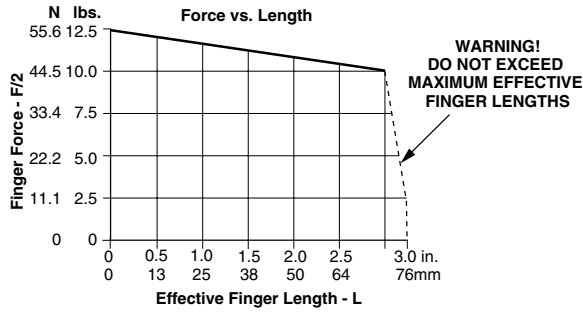

Loading capacity† - P5GP Electric Gripper

	Static (metric)
Maximum tensile T	10 N
Maximum compressive C	10 N
Maximum moment Mx	14 Nm
Maximum moment My	17 Nm
Maximum moment Mz	14 Nm

† Capacities are per set of jaws and are not simultaneous

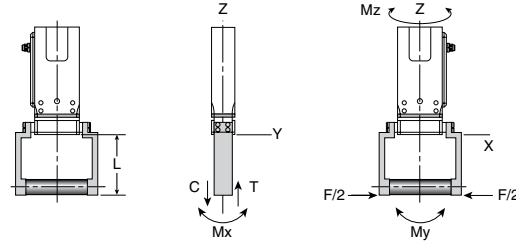

Dimensions: P5GP Electric Gripper Series

Unless otherwise noted all tolerances are as shown below

- ⌀ Dimensions are symmetrical about centerline
- Third Angle Projection
- Metric (mm)
 (0.) = (±.25)
 (0.0) = (±.13)
 (0.00) = (±.013)

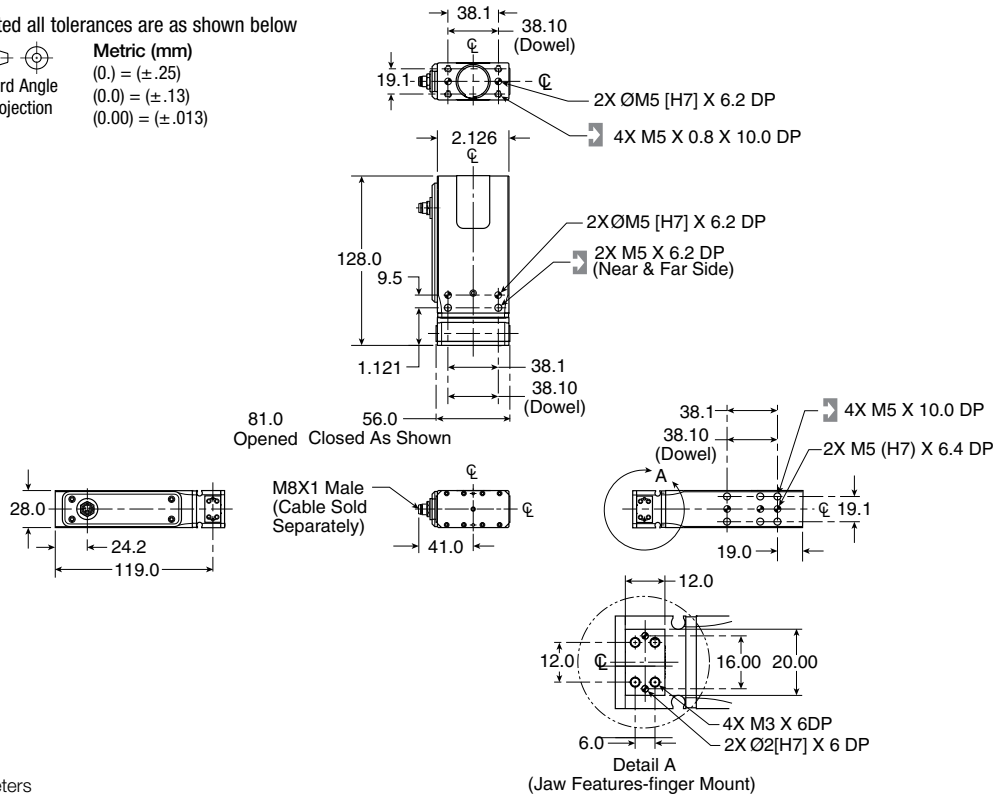

Dimensions in millimeters

- Gripper is available in two stroke lengths, standard and extended stroke
- Ridged design and full body support of the jaws allows for long finger lengths
- Finger locating sleeves for precise finger mounting (standard)
- Slip fit dowel pin holes located in body and jaws for precision mounting
- Jaw components hardened and precision ground steel for minimum jaw play with hard plating for wear resistance and long life
- IP50
- Grip force can be changed on the fly using 0-5V analog input
- No external controller needed, 8-pin cable sold separately
- Magnetic piston standard

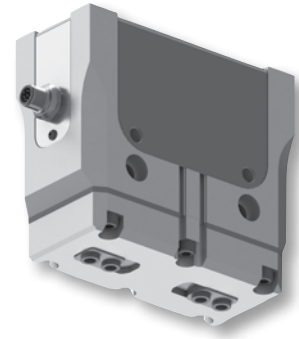

Operating information

Voltage:	24VDC
Power Req. @ 100% Duty Cycle:	10 Watts
Current - Peak:	2 Amps Max.
Current - Continuous:	0.4 Amps
Temperature range:	0° to 55° C (32° to 131° F)

Ordering Information: P5GQ Electric Gripper Series - High Force

Function	Gripping mode	Stroke (mm)	Grip force @ 7 bar (N)	Accuracy +/- mm	Repeatability +/-mm	Weight (kg)	Part number
Electric	ID	10.0	667-1334	0.05	0.025	2.52	P5GQ-000RSX010B
Electric	ID	20.0	445-890	0.05	0.025	2.52	P5GQ-000RSX020B
Electric	OD	10.0	667-1334	0.05	0.025	2.52	P5GQ-000QSX010B
Electric	OD	20.0	445-890	0.05	0.025	2.52	P5GQ-000QSX020B

Sensor part numbers: Page 53.

Loading information - P5GQ-000*010

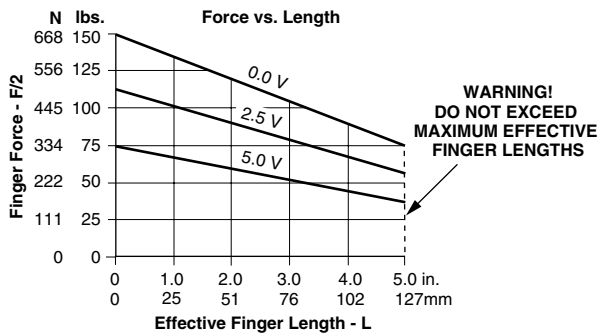

Loading information - P5GQ-000*020

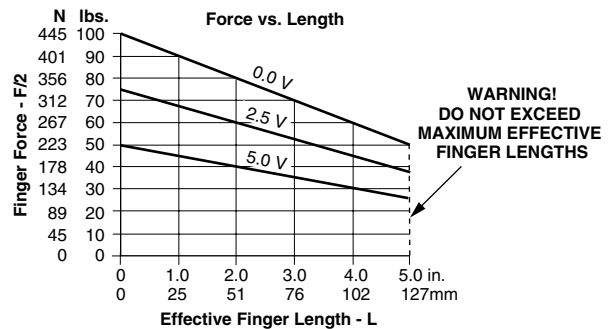

Loading capacity† - P5GQ-000*010

	Static (metric)	Dynamic (Metric)
Maximum tensile T	1564 N	259 N
Maximum compressive C	2070 N	259 N
Maximum moment Mx	76 Nm	10 Nm
Maximum moment My	106 Nm	14 Nm
Maximum moment Mz	70 Nm	14 Nm

† Capacities are per set of jaws and are not simultaneous

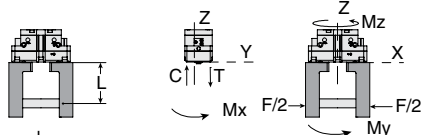

Loading capacity† - P5GQ-000*020

	Static (metric)	Dynamic (Metric)
Maximum tensile T	1394 N	168 N
Maximum compressive C	1845 N	168 N
Maximum moment Mx	68 Nm	6 Nm
Maximum moment My	84 Nm	8 Nm
Maximum moment Mz	56 Nm	8 Nm

† Capacities are per set of jaws and are not simultaneous

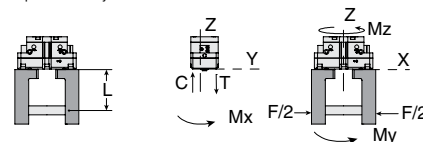

Dimensions: P5GQ Electric Gripper Series - High Force

Unless otherwise noted all tolerances are as shown below

Dimensions are symmetrical about centerline
 Third Angle Projection
Metric (mm)
 (0.) = (±.25)
 (0.0) = (±.13)
 (0.00) = (±.013)

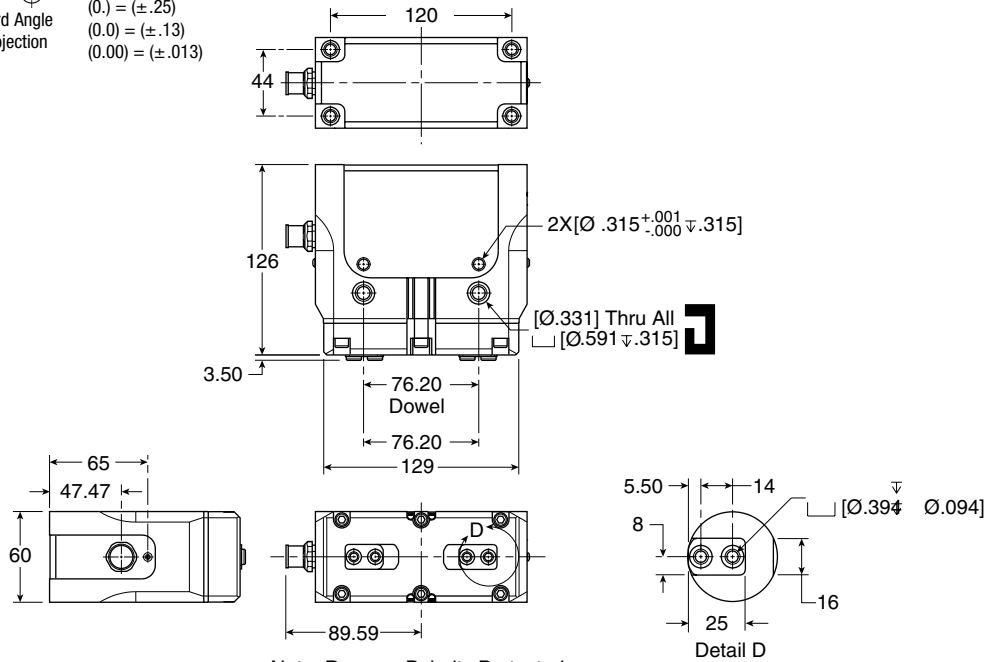

Dimensions in millimeters

P8S-CABL-052: 8 Wire power and signal cable, 5m long, straight M12 connector

P8S-CABL-053: 8 Wire power and signal cable, 5m long, 90 degree M12 connector

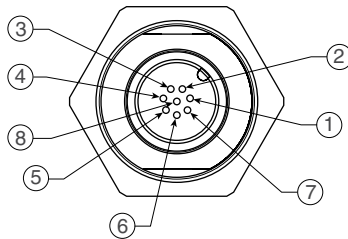

Electrical interface: Pin out (Looking into the head of the connector on gripper)

Pin #	Color	Signal	Description	Current
1	White	Force	0-5 VDC (Analog)	5mA
2	Brown	+24V	Motor power	2A (max), 0.4 A (avg)
3	Green	Open	24 VDC active (Inputs)	10mA
4	Yellow	Open sense	NPN / PNP (Outputs)	300mA (max)
5	Gray	Close	24 VDC active (Inputs)	10mA
6	Pink	Close sense	NPN / PNP (Outputs)	300mA (max)
7	Blue	Ground	Motor ground	2A (max)
8	Red	I/O power	24 VDC (PNP outputs only)	300mA (max)

- Multiple side or top air ports (top ports require o-ring)
- Optional spring assist retains the component should the air supply fail, to assist the gripper for internal (-O) or external (-C) gripping, or in single acting or spring assist mode
- Finger locating sleeves for precise finger mounting
- Jaw components hardened and precision ground steel for minimum jaw play with hard plating for wear resistance and long life
- Standard purge / scavenge port used with vacuum for clean room environments or positive pressure for harsh environments
- Gripper can be mounted from the top or bottom
- Gripper body is shielded to repel chips and other particulate from internal drive mechanism
- Magnetic piston standard

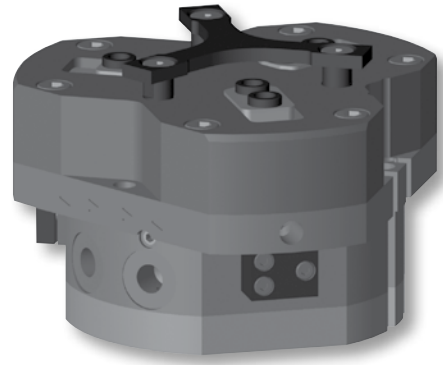

Operating information

Operating pressure:	0.3 to 7 bar (4 to 102 PSIG)
Temperature range:	
Nitrile seals (Standard)	-35° to 80° C (-30° to 180° F)
Fluorocarbon seals (Optional)	-30° to 150° C (-20° to 300° F)
Filtration requirements:	
Air filtration	40 micron or better
Air lubrication	Not necessary*
Air humidity	Low moisture content (dry)

*Addition of lubrication will greatly increase service life

Ordering Information: P5GW 3-Jaw Centering Series

Function	Bore size (mm)	Stroke (mm)	Grip force @ 7 bar (N)	Accuracy +/- mm	Repeatability +/-mm	Weight (kg)	Part number Fluorocarbon	Part number Nitrile
Double acting magnetic	32	4.0	682	0.04	0.02	0.25	P5GW-032MFG004B	P5GW-032MSG004B
Double acting magnetic	43	6.0	1238	0.04	0.02	0.53	P5GW-043MFG006B	P5GW-043MSG006B
Double acting magnetic	55	8.0	2078	0.04	0.02	1.08	P5GW-055MFG008B	P5GW-055MSG008B
Double acting magnetic	72	10.0	3644	0.06	0.03	1.95	P5GW-072MFG010B	P5GW-072MSG010B
Double acting magnetic	95	13.0	6353	0.06	0.03	3.9	P5GW-095MFG013B	P5GW-095MSG013B
Double acting magnetic	120	16.0	10202	0.08	0.04	7.89	P5GW-120MFG016B	P5GW-120MSG016B
Double acting magnetic	156	25.0	17165	0.10	0.05	15.7	P5GW-156MFG025B	P5GW-156MSG025B
Double acting magnetic	225	35.0	35288	0.10	0.05	43.9	P5GW-225MFG035B	P5GW-225MSG035B

Function	Bore size (mm)	Stroke (mm)	Grip force @ 7 bar (N)	Accuracy +/- mm	Repeatability +/-mm	Weight (kg)	Part number Spring close
Spring closing magnetic	32	4.0	889	0.04	0.02	0.25	P5GW-032DSG004B
Spring closing magnetic	43	6.0	1490	0.04	0.02	0.53	P5GW-043DSG006B
Spring closing magnetic	55	8.0	2627	0.04	0.02	1.08	P5GW-055DSG008B
Spring closing magnetic	72	10.0	4562	0.06	0.03	1.95	P5GW-072DSG010B
Spring closing magnetic	95	13.0	7877	0.06	0.03	3.9	P5GW-095DSG013B
Spring closing magnetic	120	16.0	13786	0.08	0.04	7.89	P5GW-120DSG016B
Spring closing magnetic	156	25.0	22093	0.10	0.05	15.7	P5GW-156DSG025B
Spring closing magnetic	225	35.0	44354	0.10	0.05	43.9	P5GW-225DSG035B

Sensor part numbers: Page 53.

Most popular.

Loading information - P5GW-032

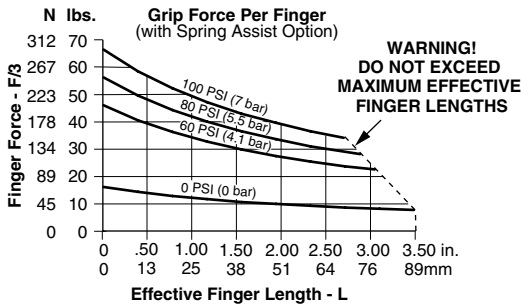

Loading information - P5GW-095

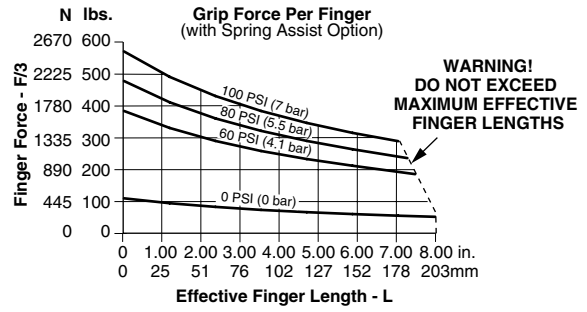

Loading information - P5GW-043

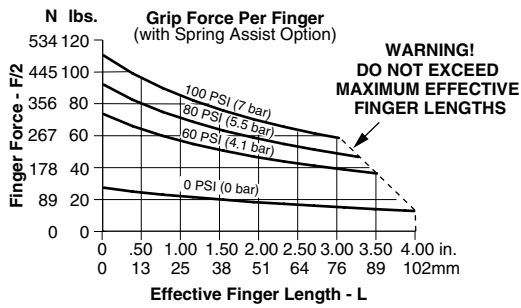

Loading information - P5GW-120

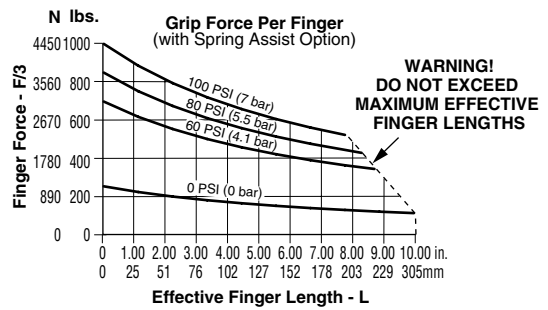

Loading information - P5GW-055

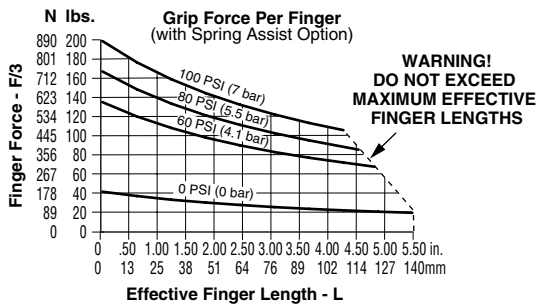

Loading information - P5GW-156

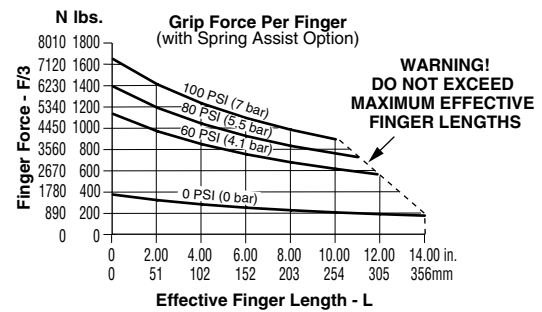

Loading information - P5GW-072

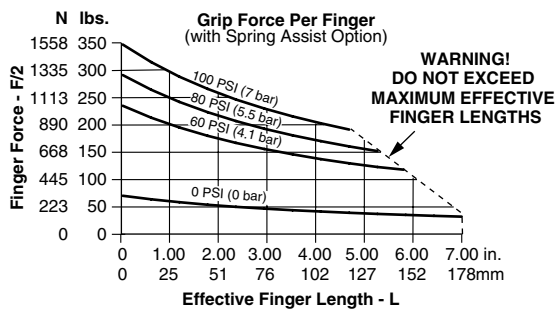

Loading information - P5GW-225

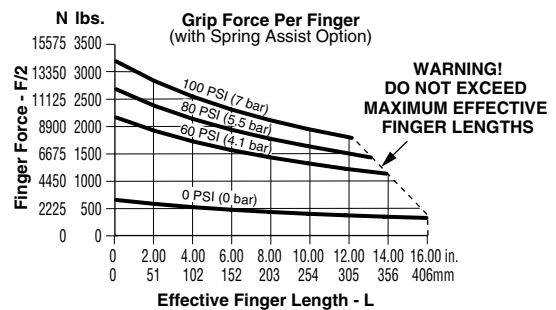

Loading capacity† - P5GW 3-Jaw Centering Series

	P5GW-32		P5GW-43		P5GW-55		P5GW-72	
	Static (metric)	Dynamic (metric)	Static (metric)	Dynamic (metric)	Static (metric)	Dynamic (metric)	Static (metric)	Dynamic (metric)
Maximum tensile T	810 N	89 N	1200 N	129 N	1680 N	302 N	2110 N	425 N
Maximum compressive C	1060 N	89 N	1560 N	129 N	2180 N	302 N	2790 N	425 N
Maximum moment Mx	22 Nm	2 Nm	45 Nm	4 Nm	72 Nm	11 Nm	92 Nm	16 Nm
Maximum moment My	28 Nm	3 Nm	64 Nm	6 Nm	102 Nm	16 Nm	182 Nm	22 Nm
Maximum moment Mz	18 Nm	3 Nm	41 Nm	6 Nm	66 Nm	16 Nm	84 Nm	22 Nm

	P5GW-95		P5GW-120		P5GW-156		P5GW-225	
	Static (metric)	Dynamic (metric)	Static (metric)	Dynamic (metric)	Static (metric)	Dynamic (metric)	Static (metric)	Dynamic (metric)
Maximum tensile T	2990 N	674 N	4320 N	1315 N	5400 N	1763 N	8230 N	2733 N
Maximum compressive C	3980 N	674 N	5810 N	1315 N	7120 N	1763 N	10700 N	2733 N
Maximum moment Mx	127 Nm	25 Nm	172 Nm	45 Nm	215 Nm	60 Nm	455 Nm	131 Nm
Maximum moment My	179 Nm	35 Nm	250 Nm	65 Nm	305 Nm	86 Nm	578 Nm	167 Nm
Maximum moment Mz	117 Nm	35 Nm	164 Nm	65 Nm	208 Nm	86 Nm	362 Nm	167 Nm

† Capacities are per set of jaws and are not simultaneous

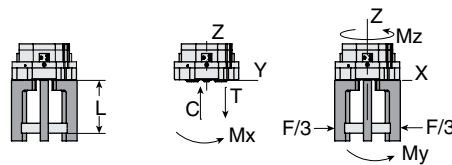

Dimensions: P5GW 3-Jaw Centering Series

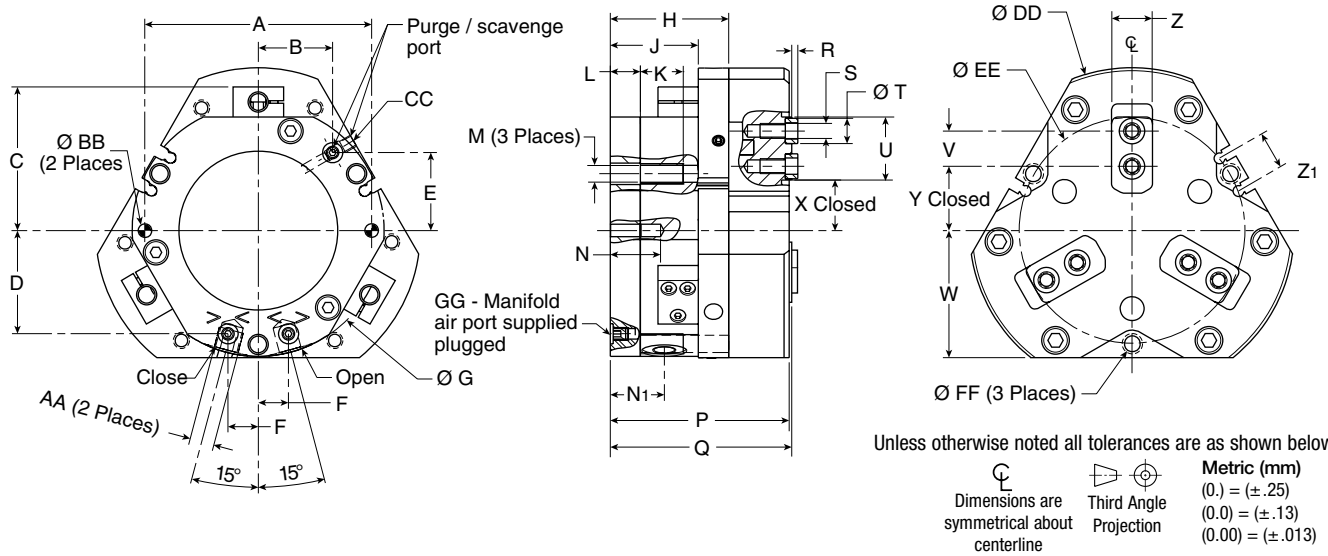

Part number	A	B	C	D	E	F	G	H	J	K	L	M	N	N ₁	P	Q	R	S
P5GW-032	45.00	13.4	—	19.5	15.8	7.0	51	24.5	18.5	9	6.0	M4	12	11.5	36.5	37.0	1.5	M3 x 5 Dp
P5GW-043	56.00	17.2	37.7	25.0	20.3	9.0	64	32.5	25.5	13	9.0	M6	15	15.5	48.5	49.0	1.5	M4 x 6 Dp
P5GW-055	70.00	23.2	46.7	32.0	23.8	9.0	80	43.5	33.5	17	12.0	M8	20	20.0	63.5	64.0	2.0	M5 x 9 Dp
P5GW-072	90.00	29.5	57.0	41.0	30.9	12.0	100	47.0	35.0	17	12.0	M8	20	21.5	71.0	72.0	2.5	M6 x 10 Dp
P5GW-095	112.00	38.4	71.0	53.0	39.5	15.0	125	57.0	42.0	22	14.0	M10	24	25.0	87.0	88.0	2.5	M6 x 10 Dp
P5GW-120	146.00	49.0	87.0	67.5	50.2	19.0	160	72.0	53.0	22	20.0	M10	30	33.0	109.0	110.0	3.0	M8 x 17 Dp
P5GW-156	184.00	64.3	106.0	87.5	63.7	23.0	200	92.0	70.0	26	24.0	M12	36	43.0	142.0	143.0	4.0	M12 x 17 Dp
P5GW-225	270.00	90.5	150.0	123.0	89.2	32.0	300	125.0	99.0	40	30.0	M20	46	60.0	195.0	196.0	5.0	M16 x 21 Dp

Part number	T	U	V	W	X	Y	Z	Z ₁	AA	BB	CC	DD	EE	FF	GG
P5GW-032	5h7	14.0	8.00	26.0	9.0	12.0	8.0	12.0	M5 x 5 Dp	3h7	M5 x 5 Dp	63	45	3.3	M3 x 4
P5GW-043	6h7	16.0	9.00	32.5	13.0	16.5	10.0	15.0	M5 x 5 Dp	4h7	M5 x 5 Dp	83	56	5.2	M3 x 4
P5GW-055	8h7	20.0	11.00	40.5	16.0	20.5	12.5	15.0	M5 x 5 Dp	5h7	M5 x 5 Dp	104	70	6.8	M4 x 6
P5GW-072	10h7	25.0	14.00	50.5	20.0	25.5	16.0	15.0	M5 x 5 Dp	5h7	M5 x 5 Dp	129	90	6.8	M5 x 6
P5GW-095	10h7	32.0	20.00	63.0	24.5	30.5	20.0	18.0	G1/8 x 8 Dp	6h7	M5 x 5 Dp	162	112	8.5	M5 x 6
P5GW-120	12h7	40.0	25.00	83.5	32.0	39.5	25.0	18.0	G1/8 x 8 Dp	6h7	M5 x 5 Dp	205	146	8.5	M5 x 6
P5GW-156	16h7	43.0	25.00	105.0	42.0	51.0	31.0	21.0	G1/8 x 8 Dp	8h7	G1/8 x 8 Dp	258	184	10.3	M5 x 6
P5GW-225	22h7	58.0	34.00	155.0	57.0	69.0	46.0	29.0	G1/8 x 12 Dp	10h7	G1/8 x 8 Dp	355	260	17.5	M8 x 10

Dimensions in millimeters

- Combination of dual bore cylinder and linear rail
- Magnetic piston standard
- Rubber bumper standard
- Available with stroke adjusters
- Available with shock absorbers



Operating information

Operating pressure: 1.5 to 7 bar (21.8 to 102 PSIG)
 Temperature range: -5° to 60° C (23° to 140° F)
 Filtration requirements:
 Air filtration: 40 micron or better
 Air lubrication: Not necessary*
 Air humidity: Low moisture content (dry)

*Addition of lubrication will greatly increase service life

Ordering Information: P5SS Slide Tables

P5	S	S	-	***	D	S	G	***	B	N	A	N	N	N																												
Family	Series	Spare		Function	Temperature / Finish	Ports	Stroke	Options	Fitting	Spare	Spare	Spare																														
S Slide	S Slide table	-		D Double acting magnetic	S Standard	G BSPP	010 10mm 020 20mm 030 30mm 040 40mm 050 50mm 075 75mm 100 100mm 125 125mm 150 150mm	B No options W With specified options pos 16-20	N None	N None	N None	N None																														
<table border="1"> <thead> <tr> <th colspan="2">Bore size</th> </tr> </thead> <tbody> <tr> <td>006</td> <td>6mm bore: 10, 20, 30, 40, 50mm stroke</td> </tr> <tr> <td>008</td> <td>8mm bore: 10, 20, 30, 40, 50, 75mm stroke</td> </tr> <tr> <td>012</td> <td>12mm bore: 10, 20, 30, 40, 50, 75, 100mm stroke</td> </tr> <tr> <td>016</td> <td>16mm bore: 10, 20, 30, 40, 50, 75, 100, 125mm stroke</td> </tr> <tr> <td>020</td> <td>20mm bore: 10, 20, 30, 40, 50, 75, 100, 125mm stroke</td> </tr> <tr> <td>025</td> <td>25mm bore: 10, 20, 30, 40, 50, 75, 100, 125, 150mm stroke</td> </tr> </tbody> </table>															Bore size		006	6mm bore: 10, 20, 30, 40, 50mm stroke	008	8mm bore: 10, 20, 30, 40, 50, 75mm stroke	012	12mm bore: 10, 20, 30, 40, 50, 75, 100mm stroke	016	16mm bore: 10, 20, 30, 40, 50, 75, 100, 125mm stroke	020	20mm bore: 10, 20, 30, 40, 50, 75, 100, 125mm stroke	025	25mm bore: 10, 20, 30, 40, 50, 75, 100, 125, 150mm stroke														
Bore size																																										
006	6mm bore: 10, 20, 30, 40, 50mm stroke																																									
008	8mm bore: 10, 20, 30, 40, 50, 75mm stroke																																									
012	12mm bore: 10, 20, 30, 40, 50, 75, 100mm stroke																																									
016	16mm bore: 10, 20, 30, 40, 50, 75, 100, 125mm stroke																																									
020	20mm bore: 10, 20, 30, 40, 50, 75, 100, 125mm stroke																																									
025	25mm bore: 10, 20, 30, 40, 50, 75, 100, 125, 150mm stroke																																									
<table border="1"> <thead> <tr> <th colspan="2">Options</th> </tr> </thead> <tbody> <tr> <td>A</td> <td>5mm adjuster extension</td> </tr> <tr> <td>B</td> <td>5mm adjuster retraction</td> </tr> <tr> <td>C</td> <td>5mm adjuster both ends</td> </tr> <tr> <td>D</td> <td>15mm adjuster extension</td> </tr> <tr> <td>E</td> <td>15mm adjuster retraction</td> </tr> <tr> <td>F</td> <td>15mm adjuster both ends</td> </tr> <tr> <td>G†</td> <td>25mm adjuster extension</td> </tr> <tr> <td>H†</td> <td>25mm adjuster retraction</td> </tr> <tr> <td>J</td> <td>25mm adjuster both ends</td> </tr> <tr> <td>K*</td> <td>Shock absorber extension</td> </tr> <tr> <td>L*</td> <td>Shock absorber retraction</td> </tr> <tr> <td>M*</td> <td>Shock absorber both ends</td> </tr> <tr> <td>N</td> <td>None</td> </tr> </tbody> </table>															Options		A	5mm adjuster extension	B	5mm adjuster retraction	C	5mm adjuster both ends	D	15mm adjuster extension	E	15mm adjuster retraction	F	15mm adjuster both ends	G†	25mm adjuster extension	H†	25mm adjuster retraction	J	25mm adjuster both ends	K*	Shock absorber extension	L*	Shock absorber retraction	M*	Shock absorber both ends	N	None
Options																																										
A	5mm adjuster extension																																									
B	5mm adjuster retraction																																									
C	5mm adjuster both ends																																									
D	15mm adjuster extension																																									
E	15mm adjuster retraction																																									
F	15mm adjuster both ends																																									
G†	25mm adjuster extension																																									
H†	25mm adjuster retraction																																									
J	25mm adjuster both ends																																									
K*	Shock absorber extension																																									
L*	Shock absorber retraction																																									
M*	Shock absorber both ends																																									
N	None																																									

* Option K, L & M shock absorber is not available on 6mm bore

† Option G & H 25mm adjuster is not available on 6mm bore

Sensor part numbers: Page 53.

Selection Flow Chart

Operating conditions	Formula and charts	Selection example
List out the operating conditions according to mounting position and shape of the workpiece	Model used Cushion style Workpiece install position Mounting position Average speed V_a (mm/s) Allowable load W (kg) (Figure 1) Overhang L_n (mm) (Figure 2)	Cylinder: P5SS-6-10 Cushion: Cushion pad Workpiece table mounting Mounting: Lateral mounting Average speed: $V_a = 150$ mm/s Load: $W = 0.3$ kg $L_1 = 4$ mm $L_2 = 4$ mm $L_3 = 4$ mm
		
Kinetic energy		
Calculate kinetic energy E (J) of work	$E = 1/2 \cdot W (V/1000)^2$	$E = 1/2 \cdot 0.3 (210/1000)^2 = 0.0066$
	Collision speed $V = 1.4 \cdot V_a$	Collision speed $V = 1.4 \cdot 150 = 210$
Calculate allowable kinetic energy E_a (J)	$E_a = K \cdot E_{max}$	$E_a = 1 \cdot 0.015 = 0.015$
	Workpiece mounting coefficient K : Figure 3	Possible to use by $E = 0.0066 \leq E_a = 0.015$
Make sure that kinetic energy of work is less / lower than allowable kinetic energy.	Max. allowable kinetic energy E_{max} : Table 1 Kinetic energy (E) \leq Allowable kinetic energy (E_a)	
Load rate		
Load rate of work		
Calculate static work W_a (kg)	$W_a = K \cdot \beta \cdot W_{max}$ Workpiece mounting coefficient K : Figure 3 Allowable load coefficient β : Figure 4 Maximum allowable moment W_{max} : Table 2	$W_a = 1 \times 1 \times 0.6 = 0.66$ $K = 1$ $\beta = 1$ $W_{max} = 0.6$
Calculate load rate α_1 of static work	$\alpha_1 = W/W_a$	$\alpha_1 = 0.3/0.6 = 0.5$
Load rate of static moment		Yawing Rolling
Calculate static moment M (Nm).	$M = W \times 9.8 (L_n + A_n)/1000$ Correction value for moment center distance A_n : Table 3	Calculate M_y Calculate M_r $M_y = W \times 9.8 (L_1 + A_3)/1000 = 0.3 \times 9.8 (4 + 13)/1000 = 0.05$ $M_r = W \times 9.8 (L_3 + A_2)/1000 = 0.3 \times 9.8 (5 + 6)/1000 = 0.033$
Calculate allowable static moment M_a (Nm).	$M_a = K \cdot \gamma \cdot M_{max}$ Workpiece mounting coefficient K : Figure 3 Allowable moment coefficient γ : Figure 5 Max. allowable moment M_{max} : Table 4	$A_3 = 13$ $A_2 = 6$ $M_{ay} = 1 \times 1 \times 0.7 = 0.7$ $M_{ar} = 0.7$ (Same value as M_a) $M_{y_{max}} = 0.7$
Calculate load rate α_2 of static moment	$\alpha_2 = M/M_a$	$\alpha_2 = 0.05/0.7 = 0.072$ $\alpha_2' = 0.033/0.7 = 0.047$
Load rate of kinetic moment		Pitching Yawing
Calculate kinetic moment M_e (Nm).	$M_e = 1/3 \cdot W_e \cdot 9.8 (L_n + A_n)/1000$ Collision equivalence load $W_e = \delta \cdot W \cdot V$ δ : Cushion coefficient with cushion pad (Standard) = 4/100 with shock absorber = 1/100	Calculate M_{ep} Calculate M_{ey} $M_{ep} = 1/3 \times 2.52 \times 9.8 \times (5 + 6)/1000 = 0.09$ $M_{ey} = 1/3 \times 2.52 \times 9.8 \times (4 + 16)/1000 = 0.165$ $W_e = 4/100 \times 0.3 \times 210 = 2.52$ $W_e = 2.52$
Calculate allowable kinetic moment M_{ea} (Nm).	Correction value for moment center distance A_n : Table 3 $M_{ea} = K \cdot \gamma \cdot M_{max}$ Workpiece mounting coefficient t K : Figure 3 Allowable moment coefficient γ : Figure 5 Max. allowable moment M_{max} : Table 4	$A_2 = 6$ $A_4 = 16$ $M_{ep} = 1 \times 0.97 \times 0.7 = 0.679$ $M_{ey} = 0.679$ (Same value as M_{ep}) $K = 1$ $\gamma = 0.97$ $M_{p_{max}} = 0.$
Calculate load rate α_3 of kinetic moment.	$\alpha_3 = M_e/M_{ea}$	$\alpha_3 = 0.09/0.679 = 0.13$ $\alpha_3' = 0.165/0.679 = 0.243$
Sum of load rate		
When sum of load rate does not exceed 1, it is possible to use.	$\sum \alpha_n = \alpha_1 + \alpha_2 + \alpha_3 \leq 1$	$\sum \alpha_n = \alpha_1 + \alpha_2 + \alpha_2' + \alpha_3 + \alpha_3' \leq 1$ $= 0.5 + 0.072 + 0.047 + 0.133 + 0.243 = 0.995 \leq 1$ And it is possible to use.

Table 1: Maximum allowable kinetic energy: Emax (J)

Allowable kinetic energy		
Cushion pad	Shock absorber	Model
0.015	—	P5SS-006
0.023	0.041	P5SS-008
0.05	0.105	P5SS-012
0.104	0.214	P5SS-016
0.153	0.313	P5SS-020
0.232	0.472	P5SS-025

Table 2: Maximum allowable static load: Wmax (kg)

Max. allowable kinetic energy	Model
0.6	P5SS-006
0.8	P5SS-008
2	P5SS-012
3.7	P5SS-016
6	P5SS-020
8.5	P5SS-025

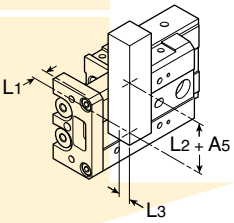
Table 3: Correction value for moment center distance: An (mm) (Refer to Figure 2)

A1	A2	A3	A4	A5	Model
11	6	13	16	16	P5SS-006
11	8	13	20	20	P5SS-008
24	9.5	26	25	25	P5SS-012
27	10.5	30	31	31	P5SS-016
34	15.5	36	38	38	P5SS-020
42	20.5	44	46	46	P5SS-025

Figure 1: Allowable load: W (kg)

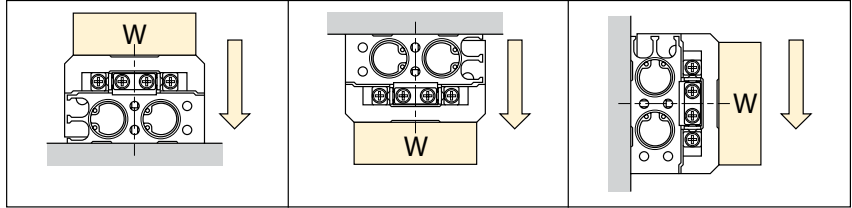
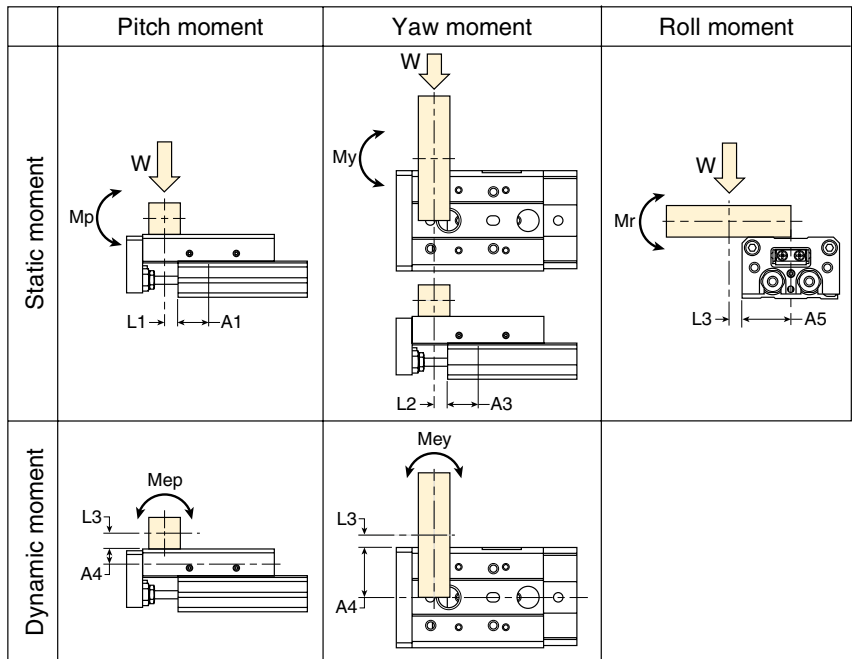

Figure 2: Overhang: Ln (mm) Correction value for moment center distance: An (mm)



Note: Static moment: Moment by gravity.
Kinetic moment: Moment by stopper collision.

Figure 3: Workpiece mounting coefficient: K

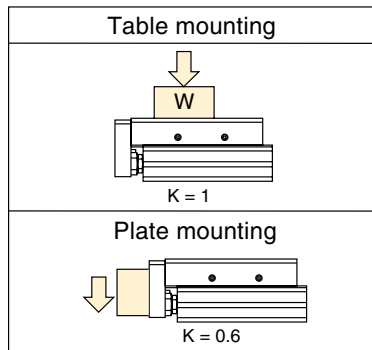

Figure 4: Allowable static load coefficient: β

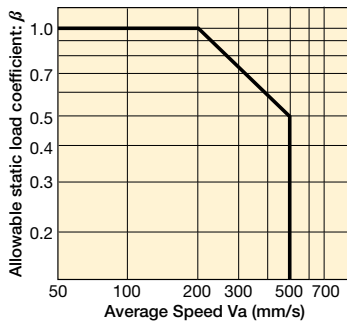
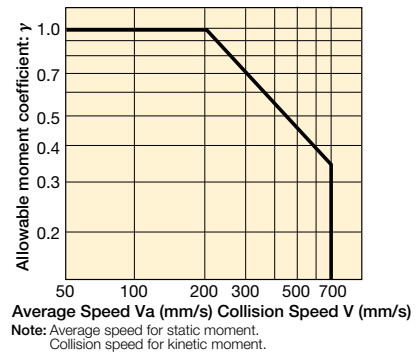

Figure 5: Allowable moment coefficient: γ



Note: Average speed for static moment.
Collision speed for kinetic moment.

Table 4: Maximum allowable moment: Mmax (Nm)

Stroke (mm)									
10	20	30	40	50	75	100	125	150	Model
0.7	1.0	1.1	1.1	1.1	—	—	—	—	P5SS-006
2.0	2.0	2.6	3.5	3.9	3.9	—	—	—	P5SS-008
3.9	3.9	3.9	5.5	6.8	9.6	9.6	—	—	P5SS-012
9.8	9.8	9.8	9.8	12.0	21.0	30.0	30.0	—	P5SS-016
16.4	16.4	16.4	16.4	24.2	31.4	45.5	45.5	45.5	P5SS-020
26.5	26.5	26.5	26.5	37.8	49.8	62.2	62.2	62.2	P5SS-025

Material

Ø 6, Ø 8

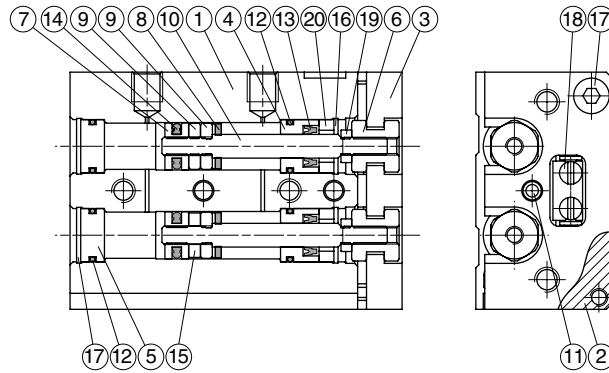

Ø 12 thru Ø 25

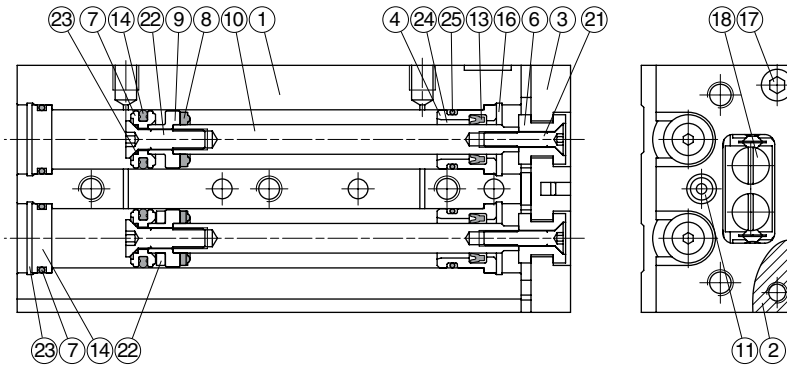

No.	Part name	6	8	12 to 25
1	Body		Aluminum alloy	
2	Table		Aluminum alloy	
3	Plate		Aluminum alloy	
4	Rod cover		Aluminum alloy	
5	Head cover		Aluminum alloy	
6	Floating connector		Stainless steel	
7	Piston		Stainless steel	Aluminum alloy
8	Cushion pad		NBR	
9	Spacer ring	Aluminum alloy	Stainless steel	Aluminum alloy
10	Piston rod		Stainless steel	
11	End cushion		PU	
12	Cover ring		NBR	
13	Rod packing		NBR	

No.	Part name	6	8	12 to 25
14	Piston packing		NBR	
15	Magnet ring		Magnet material	
16	Snap ring	Spring steel	Stainless steel	
17	Bolt		Stainless steel	
18	Slide way		Bearing steel	
19	Nut	Copper	—	
20	Rod cover washer	Stainless steel	—	
21	Floating connector bolt	Stainless steel	—	
22	Piston screw		—	Stainless steel
23	Piston gasket		—	NBR
24	Rod bush		Copper	
25	Cover ring		NBR	

Weight (g)

Stroke (mm)	Tube I.D.					
	Ø6	Ø8	Ø12	Ø16	Ø20	Ø25
10	78	137	335	536	1001	1573
20	98	148	339	546	1012	1587
30	111	171	343	552	1020	1605
40	147	216	393	630	1098	1735
50	172	255	482	723	1254	1930
75	—	367	684	1030	1690	2553
100	—	—	910	1341	2214	3180
125	—	—	—	1646	2729	4082
150	—	—	—	—	3310	4420

Dimensions: P5SS Slide Table - Ø 8

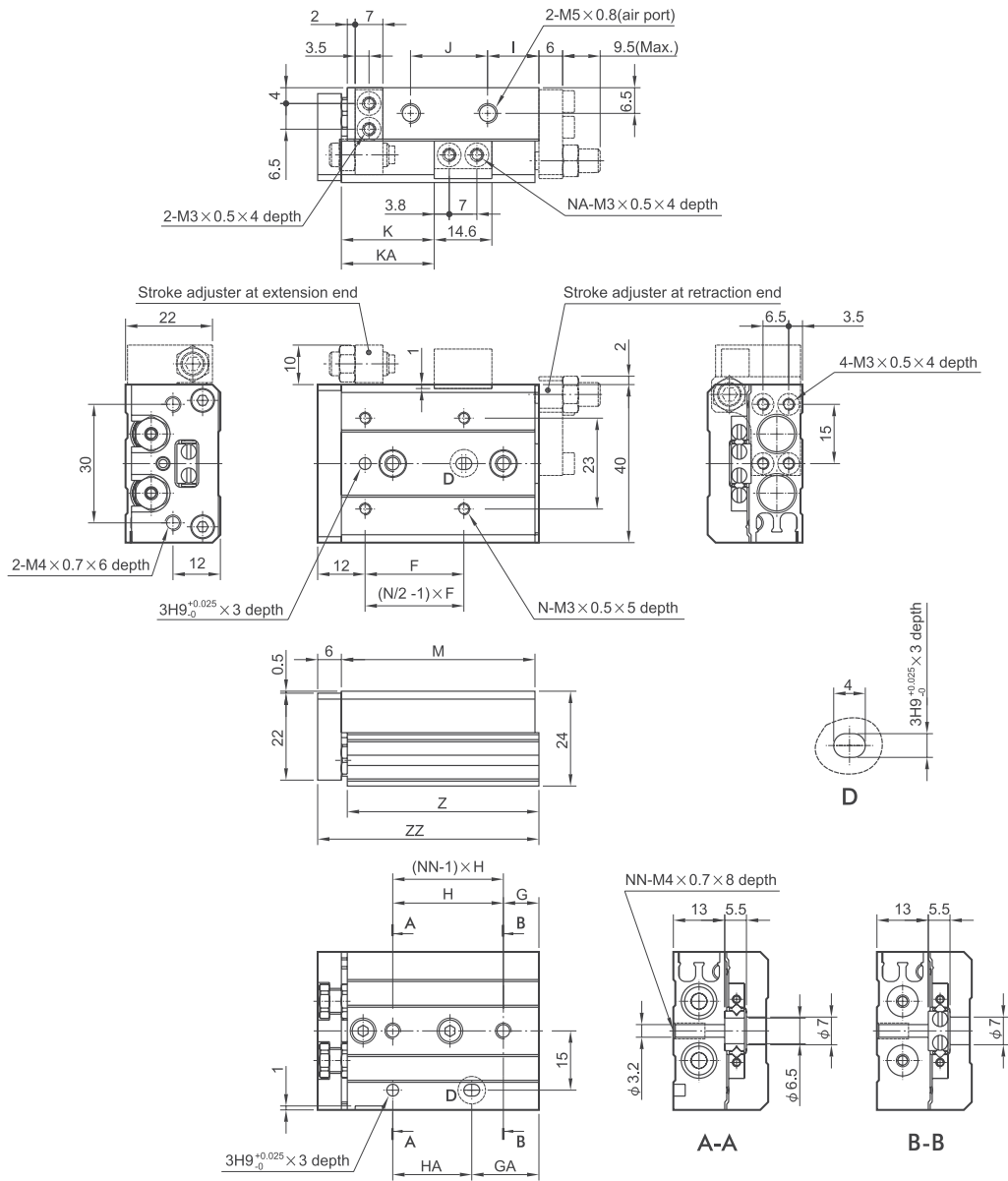

Stroke (mm)	F	G	GA	H	HA	I	J	K	KA	M	N	NA	NN	Z	ZZ
10	25	9	17	28	20	13	19.5	23.5	—	49	4	2	2	48.5	56
20	25	12	12	30	30	8.5	29	33.5	—	54	4	2	2	53.5	61
30	40	13	33	20	20	9.5	39	43.5	—	65	4	2	3	64.5	72
40	50	15	43	28	28	10.5	56	53.5	—	83	4	2	3	82.5	90
50	38	20	43	23	46	24.5	60	63.5	82.5	101	6	4	4	100.5	108
75	50	27	83	28	56	38.5	96	88.5	132.5	151	6	4	5	150.5	158

Dimensions in millimeters

Dimensions: P5SS Slide Table - Ø 12

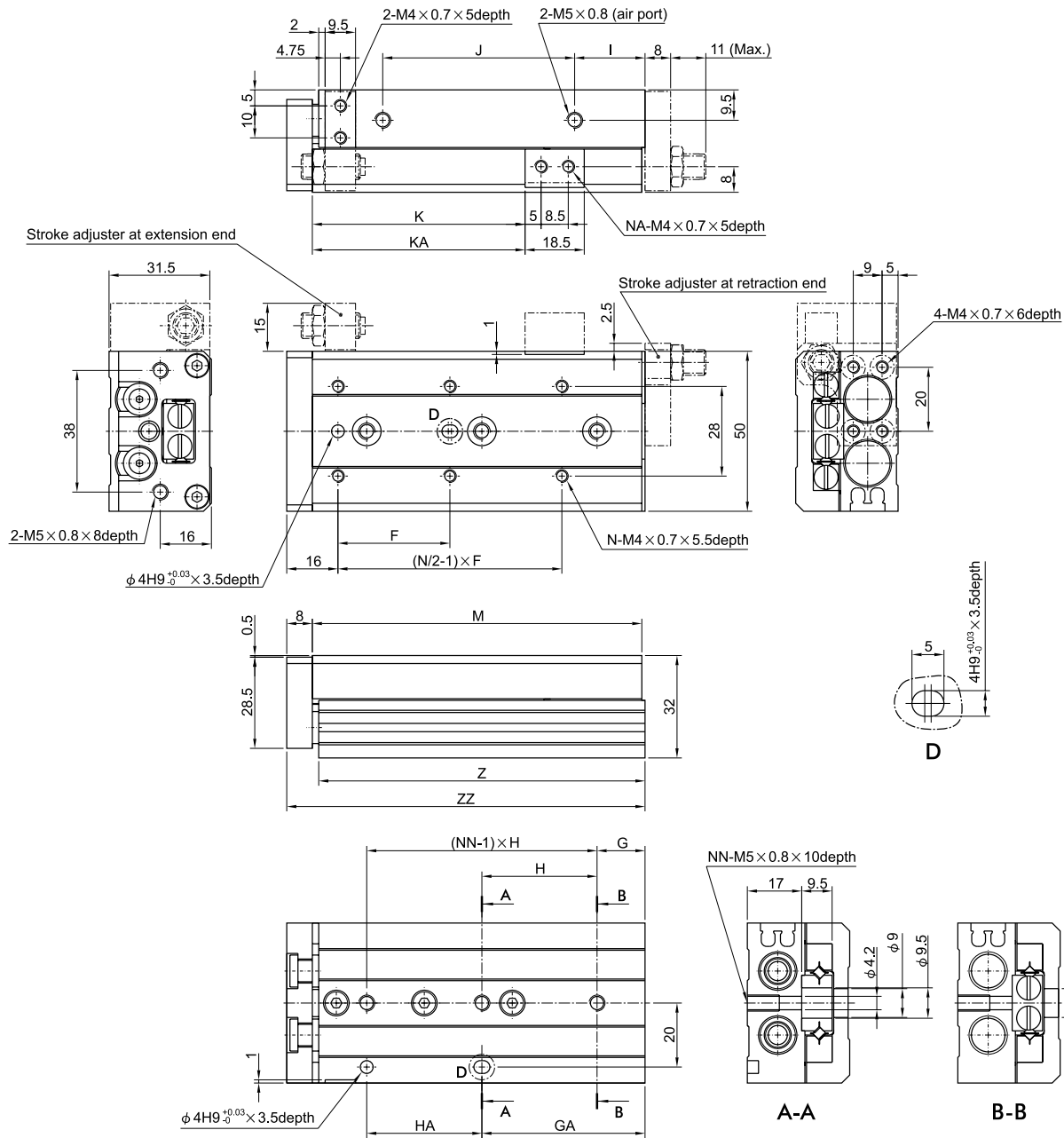

Stroke (mm)	F	G	GA	H	HA	I	J	K	KA	M	N	NA	NN	Z	ZZ
10	35	15	15	40	40	10	40	26.5	—	71	4	2	2	70	80
20	35	15	15	40	40	10	40	36.5	—	71	4	2	2	70	80
30	35	15	15	40	40	10	40	46.5	—	71	4	2	2	70	80
40	50	17	42	25	25	10	52	56.5	—	83	4	2	3	82	92
50	35	15	51	36	36	22	60	66.5	—	103	6	2	3	102	108
75	55	25	61	36	72	43	85	91.5	125.5	149	6	4	4	148	158
100	65	35	111	38	76	52	130	116.5	179.5	203	6	4	5	202	212

Dimensions in millimeters

Dimensions: P5SS Slide Table - Ø 16

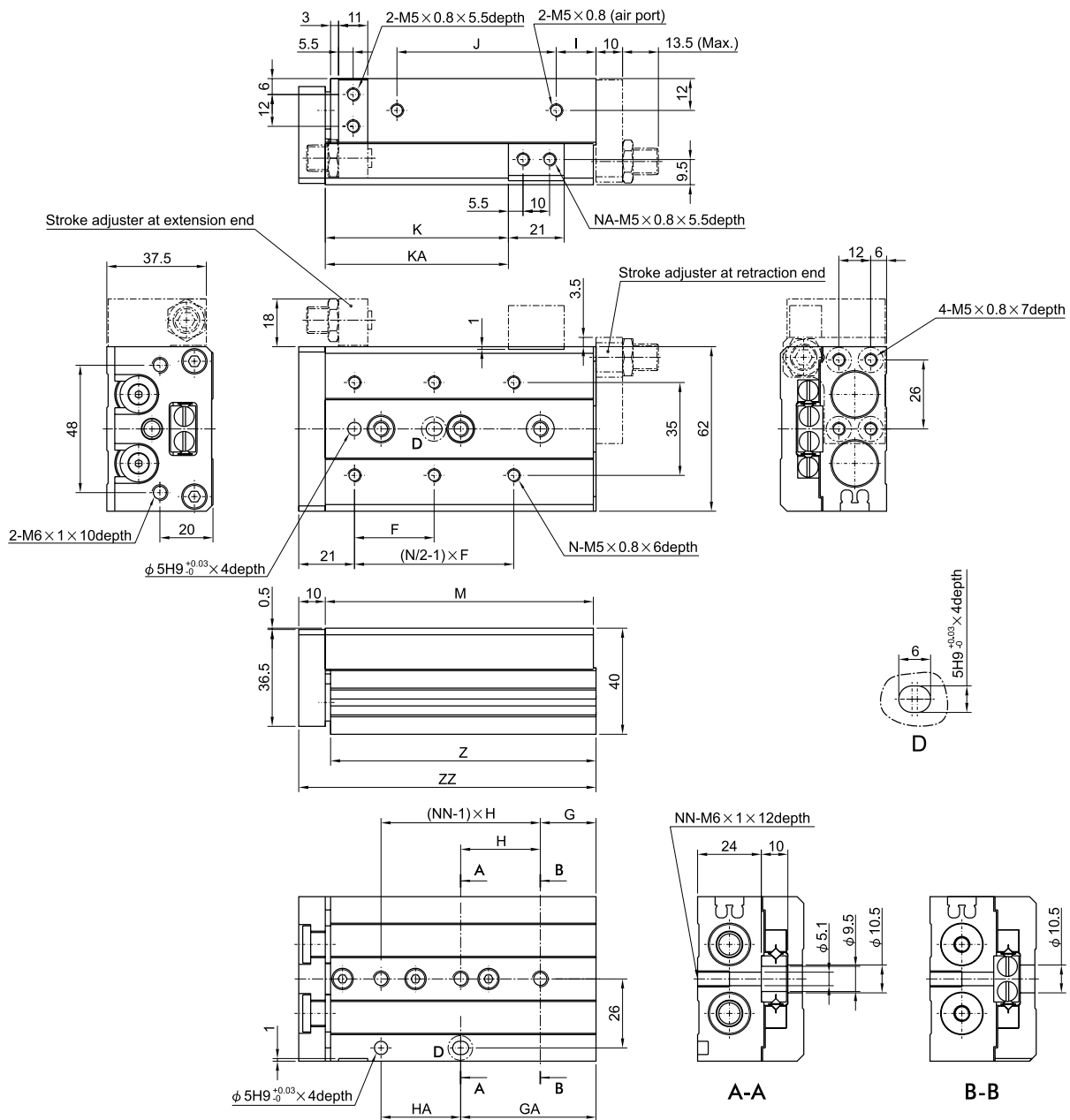

Stroke (mm)	F	G	GA	H	HA	I	J	K	KA	M	N	NA	NN	Z	ZZ
10	35	16	16	40	40	10	40	29	—	76	4	2	2	75	87
20	35	16	16	40	40	10	40	39	—	76	4	2	2	75	87
30	35	16	16	40	40	10	40	49	—	76	4	2	2	75	87
40	40	16	16	50	50	10	50	59	—	86	4	2	2	85	97
50	30	21	51	30	30	15	60	69	—	101	6	2	3	100	112
75	55	26	61	35	70	40	85	94	125	151	6	4	4	150	162
100	65	39	109	35	70	55	118	119	173	199	6	4	5	198	210
125	70	19	159	35	70	68	155	144	223	249	8	4	7	248	260

Dimensions in millimeters

Dimensions: P5SS Slide Table - Ø 25

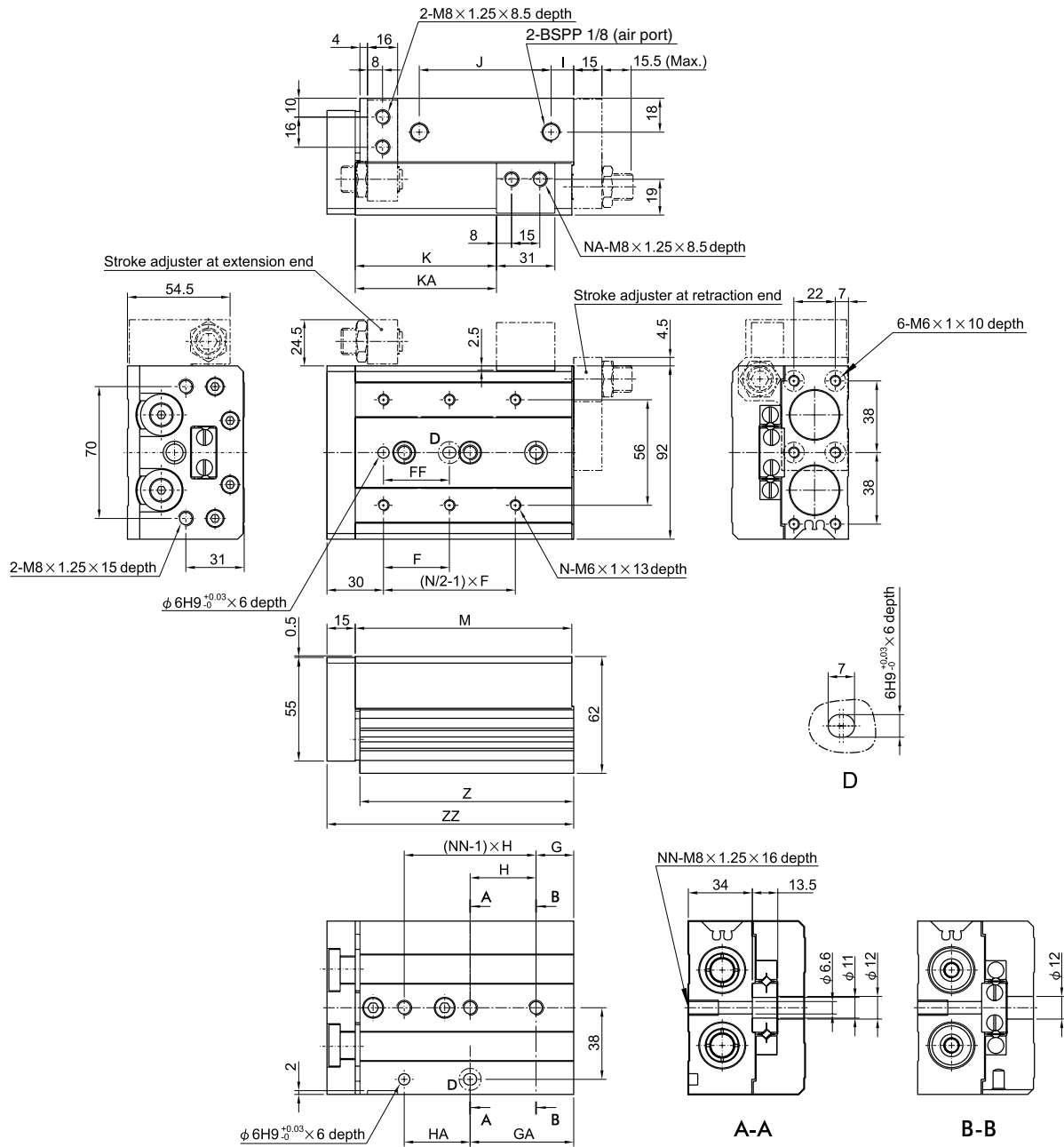

Stroke (mm)	F	FF	G	GA	H	HA	I	J	K	KA	M	N	NA	NN	Z	ZZ
10	50	40	22	22	45	45	12	47	35	—	92	4	2	2	90.5	108
20	50	40	22	22	45	45	12	47	45	—	92	4	2	2	90.5	108
30	50	40	22	22	45	45	12	47	55	—	92	4	2	2	90.5	108
40	60	50	22	22	55	55	12	57	65	—	102	4	2	2	100.5	118
50	35	35	20	55	35	35	12	70	75	—	115	6	2	3	113.5	131
75	60	60	26	61	35	70	33	90	100	—	156	6	2	4	154.5	172
100	70	70	32	102	35	70	50	114	125	162	197	6	4	5	195.5	213
125	75	75	40	154	38	76	67	155	150	218	255	8	4	6	253.5	271
150	80	80	30	190	40	80	82	180	175	258	295	8	4	7	293.5	311

Dimensions in millimeters



Stroke Adjusters

Stroke Adjuster at Extension End

Mounted to Body

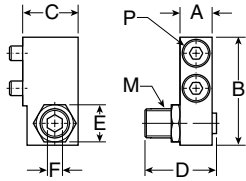

Mounted to Table

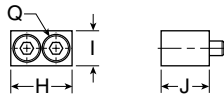

Tube I.D.	Part number	Adjustable stroke range (mm)	Mounted to body								Mounted to table			
			A	B	C	D	E	F	M	P*	H	I	J	Q*
6	P5SS-006-EA-05	5				16.5	7	2.5	M5 x .08	M2.5 x 10	12.5	6	8.5	M2.5 x .08
	P5SS-006-EA-15	15	6	17.8	10.5	26.5								
8	P5SS-008-EA-05	5				16.5								
	P5SS-008-EA-15	15	7	21.5	11	26.5	8	3	M6 x 1	M3 x 10	14.6	7	10	M3 x 10
	P5SS-008-EA-25	25				36.5								
12	P5SS-012-EA-05	5				20								
	P5SS-012-EA-15	15	9.5	31	16	30	11	4	M8 x 1	M4 x 16	18.5	10	13	M4 x 12
	P5SS-012-EA-25	25				40								
16	P5SS-016-EA-05	5				24.5								
	P5SS-016-EA-10	15	11	37	19	34.5	14	5	M10 x 1	M5 x 16	21	12	16.5	M5 x 16
	P5SS-016-EA-25	25				44.5								
20	P5SS-020-EA-05	5				27.5								
	P5SS-020-EA-15	15	13	45.5	24	37.5	17	6	M12 x 1.25	M6 x 20	25	13	21	M6 x 20
	P5SS-020-EA-25	25				47.5								
25	P5SS-025-EA-05	5				32.5								
	P5SS-025-EA-15	15	16	53.5	26.5	42.5	19	6	M14 x 1.5	M8 x 25	31	17	25.5	M8 x 25
	P5SS-025-EA-25	25				52.5								

*Size of hexagon socket head cap screws

Stroke Adjuster at Retraction End

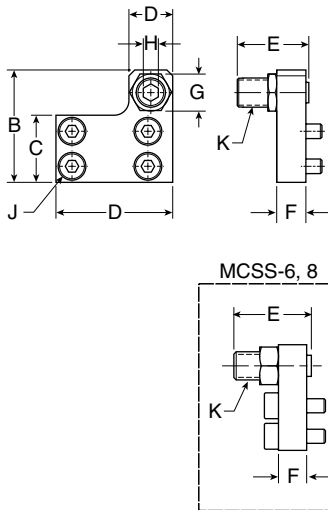

Tube I.D.	Part number	Adjustable stroke range (mm)	Mounted to table										
			A	B	C	D	E	F	G	H	J*	K	
6	P5SS-006-RA-05	5	21	19	10.5	8	16.5	5	7	2.5	M2.5 x 8	M5 x .08	
	P5SS-006-RA-15	15				26.5							
8	P5SS-008-RA-05	5				16.5							
	P5SS-008-RA-15	15	25	22.5	12.5	9	26.5	6	8	3	M3 x 10	M6 x 1	
	P5SS-008-RA-25	25				36.5							
12	P5SS-012-RA-05	5				20							
	P5SS-012-RA-15	15	32	31	18.5	13	30	8	12	4	M4 x 8	M8 x 1	
	P5SS-012-RA-25	25				40							
16	P5SS-016-RA-05	5				24.5							
	P5SS-016-RA-15	15	40	38.5	12	15	34.5	10	14	5	M5 x 10	M10 x 1	
	P5SS-016-RA-25	25				44.5							
20	P5SS-020-RA-05	5				27.5							
	P5SS-020-RA-15	15	50	48	29	21	37.5	12	17	6	M5 x 12	M12 x 1.25	
	P5SS-020-RA-25	25				47.5							
25	P5SS-025-RA-05	5				32.5							
	P5SS-025-RA-15	15	60	58	35	23	42.5	15	19	6	M6 x 16	M14 x 1.5	
	P5SS-025-RA-25	25				52.5							

*Size of hexagon socket head cap screws

Dimensions in millimeters



Shock Absorbers

Shock Absorber at Extension End

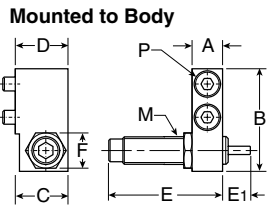

Mounted to Table

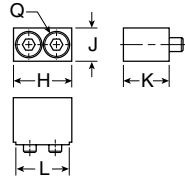

Tube		Mounted to body										Mounted to table				
I.D.	Part number	A	B	C	D	E	E1	F	M	P*	H	J	K	L	Q*	
8	P5SS-008-ESK	7	23	14	15.5	40.8	8	11	M8 x 1	M3 x 16	16.6	7	15.5	14.6	M3 x 16	
12	P5SS-012-ESK	9.5	31	14.5	16	40.8	8	11	M8 x 1	M4 x 16	20.5	10	15	18.5	M4 x 12	
16	P5SS-016-ESK	11	37	17.5	19	43.2	6.6	12.7	M10 x 1	M5 x 16	23	12	18.5	21	M5 x 16	
20	P5SS-020-ESK	13	45.5	23.5	26	86.6	12.7	19	M14 x 1.5	M6 x 25	25.5	13	25.5	25	M6 x 25	
25	P5SS-025-ESK	16	53.5	23.5	26.5	86.6	12.7	19	M14 x 1.5	M8 x 25	25.5	17	25.5	31	M8 x 25	

*Size of hexagon socket head cap screws

Shock Absorber at Retraction End

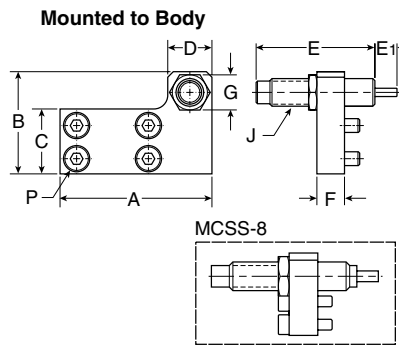

Mounted to Table

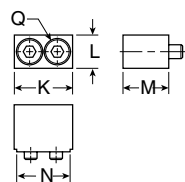

Tube		Mounted to body										Mounted to table				
I.D.	Part number	A	B	C	D	E	E1	F	G	M	P*	K	L	M	N	Q*
8	P5SS-008-RSK	38	23	12.5	14	40.8	8	8	12	M8 x 1	M3 x 12	16.6	7	15.5	14.6	M3 x 16
12	P5SS-012-RSK	45	31	18	14	40.8	8	8	11	M8 x 1	M4 x 8	20.5	10	15	18.5	M4 x 12
16	P5SS-016-RSK	55	37	23.5	16	43.2	6.6	10	12.7	M10 x 1	M5 x 10	23	12	18.5	21	M5 x 16
20	P5SS-020-RSK	70	47	29	23	86.6	12.7	12	19	M14 x 1.5	M5 x 12	25.5	13	25.5	25	M6 x 25
25	P5SS-025-RSK	80	54	35	23	86.6	12.7	15	19	M14 x 1.5	M6 x 16	25.5	17	25.5	31	M8 x 25

*Size of hexagon socket head cap screws

Dimensions in millimeters

- Twin rack and pinion
- Adjustable between 0° and 190°
- Magnetic piston standard
- Stroke adjusters standard
- Available with shock absorbers

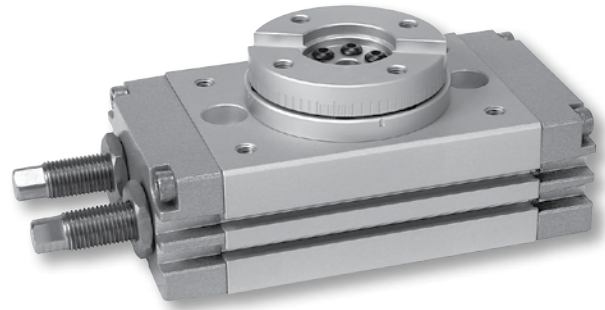

Operating information

Operating pressure:	1 to 9 bar (14.5 to 130.5 PSIG)
Temperature range:	-5° to 60° C (23° to 140° F)
Filtration requirements:	
Air filtration	40 micron or better
Air lubrication	Not necessary*
Air humidity	Low moisture content (dry)

*Addition of lubrication will greatly increase service life

Ordering Information: P5RS Rotary Tables

Description	Ports (BSPP)	Rotation	Torque (N-m at 7 bar)	Weight (kg)	Part number
Rotary table, stroke adjusters	1/8	190 degrees	1.69	0.7	P5RS-016DSG190B
Rotary table, stroke adjusters	1/8	190 degrees	3.52	1.16	P5RS-020DSG190B
Rotary table, stroke adjusters	1/8	190 degrees	6.87	1.57	P5RS-025DSG190B
Rotary table, stroke adjusters	1/8	190 degrees	13.52	3.07	P5RS-032DSG190B
Rotary table, shock absorber	1/8	190 degrees	1.69	0.7	N/A
Rotary table, shock absorber	1/8	190 degrees	3.52	1.16	N/A
Rotary table, shock absorber	1/8	190 degrees	6.87	1.57	P5RS-025DSG190WNSNNN
Rotary table, shock absorber	1/8	190 degrees	13.52	3.07	P5RS-032DSG190WNSNNN

Sensor part numbers: Page 53.

Material

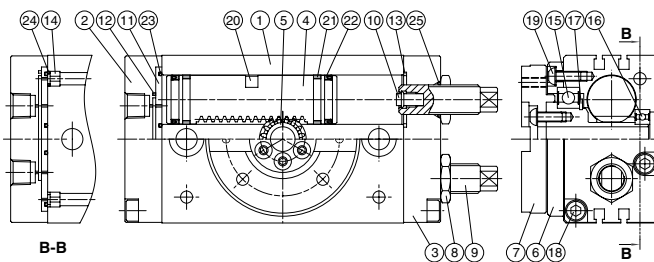

No.	Part name	Material	No.	Part name	Material
1	Body	Aluminum alloy	14	Fixed	Copper
2	Cover	Aluminum alloy	15	Ball bearing	Bearing steel
3	End cover	Aluminum alloy	16	Ball bearing	Bearing steel
4	Piston	Stainless steel	17	Snap ring	Spring steel
5	Pinion	SCM	18	Screw	SCM
6	Bearing retainer	Aluminum alloy	19	Screw	SCM
7	Table	Aluminum alloy	20	Magnet	Magnet material
8	Seal nut	Stainless steel	21	Wearing	PTFE
9	Shock absorber	Stainless steel	22	Piston packing	NBR
10	Cushion pad	NBR	23	O-ring	NBR
11	Plate	Aluminum alloy	24	O-ring	NBR
12	Packing	NBR	25	O-ring	NBR
13	Gasket	NBR			

☐ Most popular.



Load capacity - P5RS Rotary Table

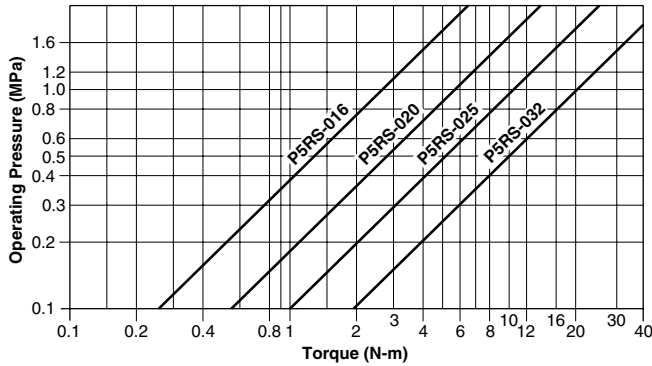

Allowable load

Set the load and moment to be applied to the table within the allowable values shown in the table below. (Values outside of limitations will cause excessive play, deteriorate accuracy, and shorten service life)

Bore	Allowable radial load (N)	Allowable thrust load (N)		Allowable moment (Nm)
		(a)	(b)	
16	78	74	78	2.4
20	147	137	137	4.0
25	196	197	363	5.3
32	314	296	451	9.7

Dimensions: P5RS Rotary Tables

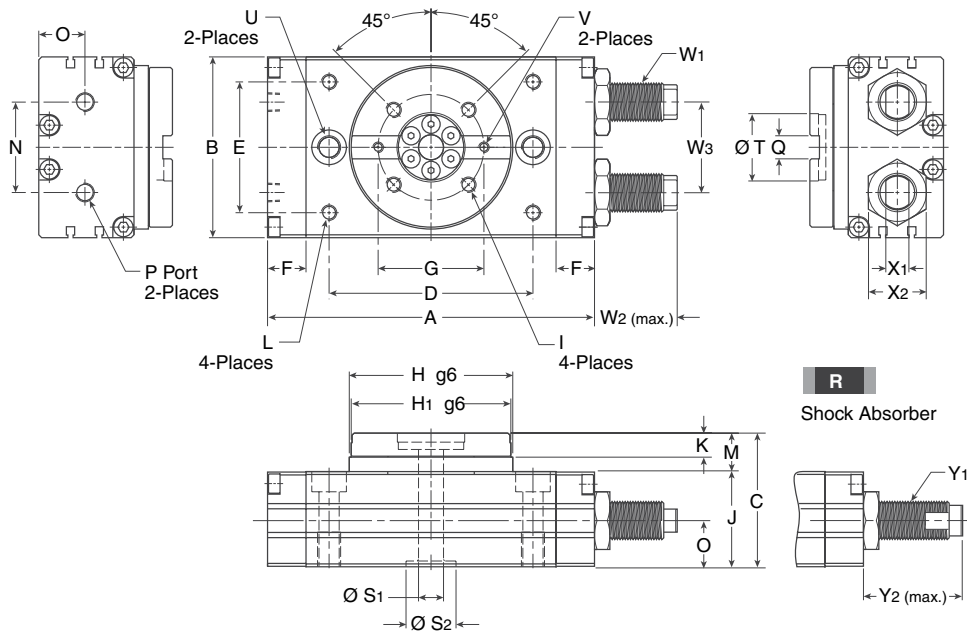

Tube I.D.	A	B	C	D	E	F	G	H	H ₁	I	J	K	L	M	N	O	P	Q
16	108	58	47	62	38	15	38	50	48	M5 x 7 Dp, P.C.D38	33	8	M5 x 8 Dp	14	26	15.5	BSPP 1/8	8 ^{+0.03} ₀ (wide) x 3.3 Dp
20	128	68	55	78	47	15	46	62.5	60	M6 x 7 Dp, P.C.D46	38	10	M6 x 8 Dp	17	27	18.5	BSPP 1/8	10 ^{+0.03} ₀ (wide) x 3.5 Dp
25	135.5	77	58.5	84	55	15.5	48	67	65	M6 x 9 Dp, P.C.D48	41.5	10	M6 x 8 Dp	17	37	20	BSPP 1/8	12 ^{+0.03} ₀ (wide) x 4 Dp
32	170	94	69.5	106	68	20	55	85	83	M8 x 10 Dp, P.C.D55	49.5	12.5	M8 x 8.5 Dp	20	47	24	BSPP 1/8	12 ^{+0.03} ₀ (wide) x 5 Dp

Tube I.D.	S ₁	S ₂	T	U	V	W ₁	W ₂	W ₃	X ₁	X ₂	Y ₁	Y ₂
16	6	17 (H7) x 2.5 Dp	24 (H7) x 3 Dp	2-Ø 6.8 thru, Ø 11 x 6.5 Dp, M8 x 12 Dp (Sink)	M3 x 4 Dp	M10 x 1.0	27	26	7	17	N/A	31
20	10	22 (H7) x 2.5 Dp	32 (H7) x 3 Dp	2-Ø 8.6 thru, Ø 14 x 8.5 Dp, M10 x 15 Dp (Sink)	M4 x 6 Dp	M12 x 1.0	23	32	8	19	N/A	36
25	13	22 (H7) x 3 Dp	32 (H7) x 3.7 Dp	2-Ø 8.6 thru, Ø 14 x 8.5 Dp, M10 x 15 Dp (Sink)	M4 x 8 Dp	M14 x 1.5	36	37	8	22	MC150M-NB	52
32	13	26 (H7) x 3 Dp	35 (H7) x 4.7 Dp	2-Ø 10.5 thru, Ø 18 x 10.5 Dp, M12 x 18 Dp (Sink)	M5 x 8.5 Dp	M20 x 1.5	43	47	12	30	MC225M-NB	62

Dimensions in millimeters



- Most effective mechanism for separating parts fed from a track or conveyor
- 7075-T6 aircraft quality aluminum body hard-coat anodized 60 RC with PTFE impregnation
- Adjustable retract stops
- Built-in sensor mounting slots
- Built-in sensor magnet for use with Hall Effect sensors
- Sealed design repels contaminants
- Slip fit dowel holes in body for precision applications
- Dynamic components are precision ground and hardened for wear resistance and long life
- Locking key ensures part separation and eliminates jams

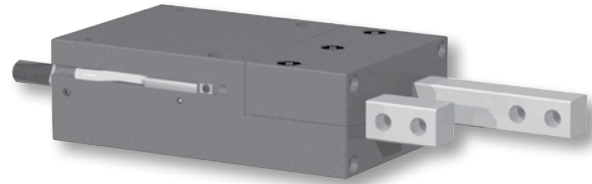

Operating information

Operating pressure:	3 to 7 bar (44 to 102 PSIG)
Temperature range:	
Nitrile seals (Standard)	-35° to 80° C (-30° to 180° F)
Filtration requirements:	
Air filtration	40 micron or better
Air lubrication	Not necessary*
Air humidity	Low moisture content (dry)
*Addition of lubrication will greatly increase service life	

Ordering Information: P5MD Feed Escapements

Stroke (mm)	Thrust force @ 7 Bar (N)	Parts escaped per minute	Weight (kg)	Side finger mount	Top finger mount
15.9	111	150	0.15	P5MD-014SSG016B	P5MD-014TSG016B
25.4	222	100	0.39	P5MD-020SSG025B	P5MD-020TSG025B
31.8	400	85	0.83	P5MD-027SSG032B	P5MD-027TSG032B

Sensor part numbers: Page 53.

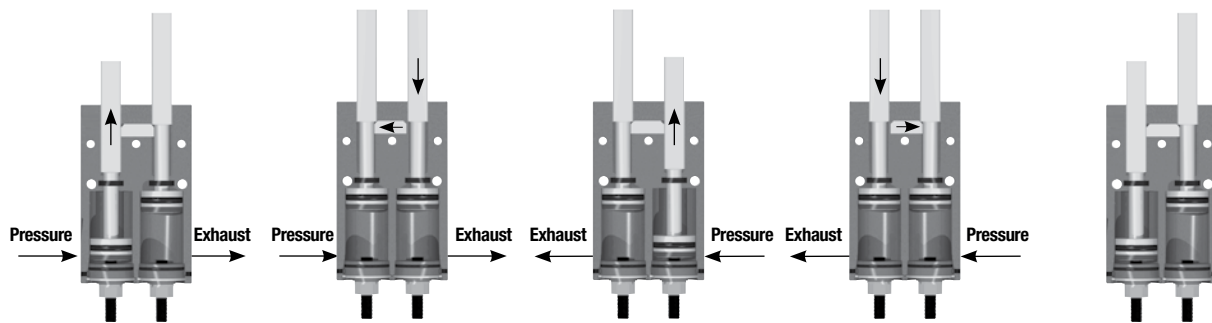

- Dual double acting pistons slide in opposite directions within the body through the use of internal porting.
- When pressure is applied, one piston extends and passes a port in its cylinder wall which is linked to the retract side of the other piston's cylinder.
- The second piston then begins to retract and pushes the locking key aside into the cavity on the side of the first finger.
- Locking Key ensures only 1 finger can be retracted at a time.
- Finger must be allowed to fully extend for proper operation.

Most popular.



Loading capacity - P5MD Feed Escapements

	P5MD-014		P5MD-020		P5MD-027	
	Static (metric)	Dynamic (metric)	Static (metric)	Dynamic (metric)	Static (metric)	Dynamic (metric)
Maximum moment Mx	6 Nm	0.57 Nm	17 Nm	1.70 Nm	28 Nm	2.83 Nm
Maximum moment My	6 Nm	0.57 Nm	17 Nm	1.70 Nm	28 Nm	2.83 Nm
Maximum moment Mz	6 Nm	0.57 Nm	17 Nm	1.70 Nm	28 Nm	2.83 Nm

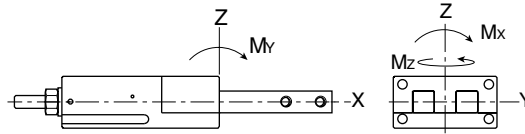

Dimensions: P5MD Feed Escapements

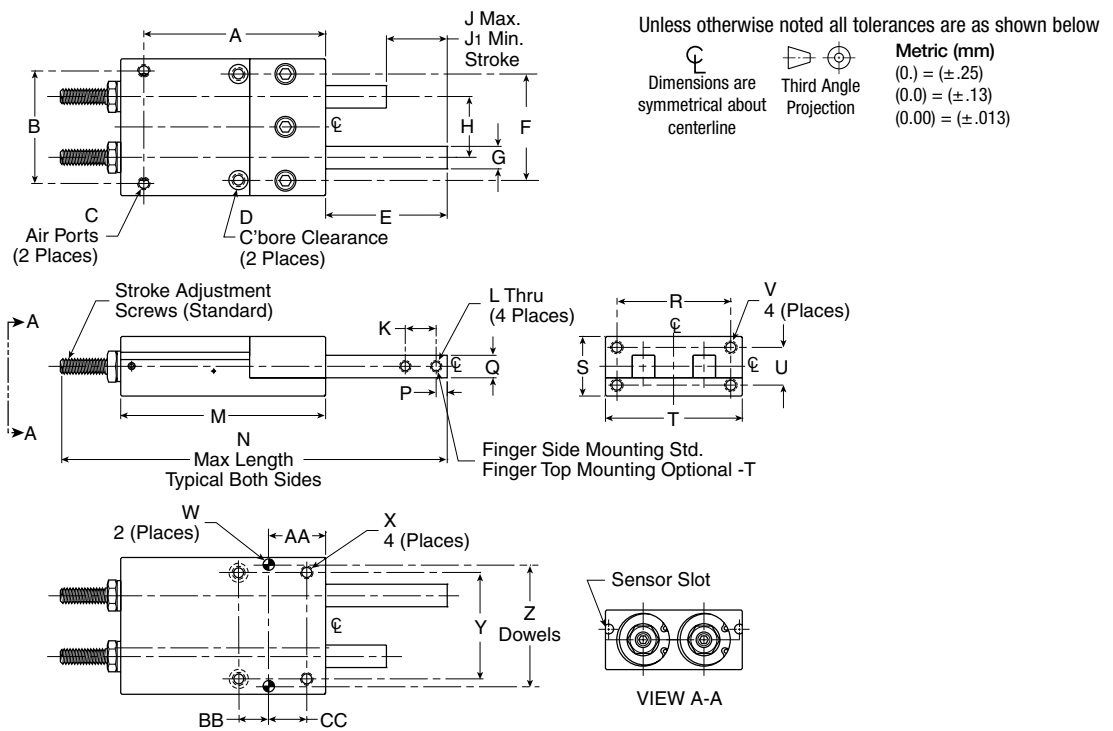

Magnetic

Series	PNP with quick disconnect M8	NPN with quick disconnect M8	PNP with quick disconnect (90 degrees) M8	NPN with quick Disconnect (90 Degrees) M8	Page
P5GM	P8S-HHSP-017	P8S-HHSN-017	P8S-HHSP-011	P8S-HISN-011	20
P5GN	P8S-HHSP-017	P8S-HHSN-017	P8S-HHSP-011	P8S-HISN-011	17
P5GP	P8S-HHSP-017	P8S-HHSN-017	NA	NA	29
P5GQ	P8S-HHSP-017	P8S-HHSN-017	NA	NA	31
P5GR	P8S-HHSP-017	P8S-HHSN-017	P8S-HHSP-011	P8S-HISN-011	23
P5GS	P8S-HHSP-017	P8S-HHSN-017	P8S-HHSP-011	P8S-HISN-011	20
P5GT	NA	NA	NA	NA	26
P5GU	P8S-HHSP-017	P8S-HHSN-017	NA	NA	14
P5GV	NA	NA	NA	NA	9
P5GW	P8S-HHSP-017	P8S-HHSN-017	P8S-HHSP-011	P8S-HISN-011	29
P5MD	P8S-HHSP-017	P8S-HHSN-017	NA	NA	51

Inductive

Series	PNP M8 disconnent	NPN M8 disconnent	PNP M12 disconnent	NPN M12 disconnent	Inductive sensor mounting kit	Page
P5GR-010	P8S-HISP-014	P8S-HISN-014	NA	NA	P8S-HSMK-119	11
P5GR-014					P8S-HSMK-119	11
P5GR-021					P8S-HSMK-120	11
P5GS-016	P8S-HISP-019	P8S-HISN-019	NA	NA	P8S-HSMK-116	23
P5GS-024					P8S-HSMK-117	23
P5GS-032					P8S-HSMK-118	23
P5GT-025	P8S-HISP-019	P8S-HISN-019	NA	NA	P8S-HSMK-003	26
P5GT-025					P8S-HSMK-003	26
P5GT-032					P8S-HSMK-003	26
P5GT-046	P8S-HISP-011	P8S-HISN-011	NA	NA	P8S-HSMK-072	26
P5GT-064					P8S-HSMK-072	26
P5GT-089					P8S-HSMK-073	26
P5GW-072	P8S-HISP-011	P8S-HISN-011	NA	NA	NA	26
P5GW-95					NA	33
P5GW-120					NA	33
P5GW-156	NA	NA	P8S-HISN-017	P8S-HISP-017	NA	33
P5GW-220					NA	33

Sensors for Economy Grippers, Slide Tables, Rotary Tables

Series	Reed switch 5-120V AC/DC	Reed switch 5-120V AC/DC M8	NPN 5-30 VDC	NPN 5-30VDC M8	PNP 5-30 VDC	PNP 5-30VDC M8	Page
P5SS	P8S-ERFXS	P8S-ERSUS	P8S-ENFXS	P8S-ENSUS	P8S-EPFXS	P8S-EPSUS	37
P5GA	P8S-ERFXS	P8S-ERSUS	P8S-ENFXS	P8S-ENSUS	P8S-EPFXS	P8S-EPSUS	5
P5GB	P8S-ERFXS	P8S-ERSUS	P8S-ENFXS	P8S-ENSUS	P8S-EPFXS	P8S-EPSUS	7
P5RS	P8S-FRFXS	P8S-FRSUS	P8S-FNFXS	P8S-FNSUS	P8S-FPFXS	P8S-FPSUS	49

Cables

2 meter cable M8	5 meter cable M8	2 meter cable M12	5 meter cable M12
P8S-CABL-010	P8S-CABL-013	P8S-CABL-014	P8S-CABL-018



Model	P8S-FRFXS P8S-FRSUS (M8)	P8S-FNFXS	P8S-FPFXS
Wiring method	2 wire	3 wire	
Switching logic	SPST normally open	Solid state output, normally open	
Switch type	Reed switch	NPN current sinking	PNP current sourcing
Operating voltage	5 to 120 V DC/AC	5 to 30 VDC	
Switching voltage	100 mA max.	200 mA max.	
Contact rating	10 W max.	6 W max.	
Current consumption	—	8 mA @ 24 V max. (Switch active)	
Voltage drop	3.5 V max.	1 V @ 200 mA max.	
Leakage current	—	0.01 mA max.	
Indicator	Red LED	Red LED	Green LED
Cable	2.8 Ø, 2C	2.8 Ø, 3C	
Magnet frequency (1)	60 Gauss	40 Gauss	
Temperature range	-10°C to 70°C (14°F to 158°F)		
Shock (2)	30 G	50 G	
Vibration (3)	9 G		
Enclosure classification	IEC 529, IP67		
Protection circuit	None	Power source reverse polarity; surge suppression	
Connect diagram			

(1) Measuring standard target: Ø 15.5 x Ø 8 x 5t (Anisotropy rubber magnet).

(2) Sine wave / X.Y.Z 3 directions / 3 times each direction / 11ms each time.

(3) Double amplitude 1.5 mm / 10 Hz -55 Hz-10 Hz (Sweep 1min / X.Y.Z. 3 directions / 1 hour each time.

Model	P8S-ERFXS P8S-ERSUS (M8)	P8S-ENFXS P8S-ENSUS (M8)	P8S-EPFXS P8S-EPSUS (M8)
Switch type	Reed switch	NPN current sinking	PNP current sourcing
Contacts	Normal open		
Voltage range	5 to 120 V DC/AC	5 to 30 V DC	
Current range	100 mA max.	50 mA max.	
Contact rating	6 W max.	1.5 W max.	
Shock resistance	30 G	50 G	
Voltage drop	0.5 V max.		1.5V max.
Response time	Max. 1 ms		
Temperature range	-10°C to 70°C (14°F to 158°F)		
Lead wire	2.8 Ø, 3C		3.0 Ø, 3C, PU
Lead wire length	2 m		
Indicator lamp	LED lights up when ON		
Enclosure classification	IP67 (NEMA 6)		IEC 529, IP67
Indicator	Red LED		Green LED
Connect diagram			

Wiring of the QD

2 wire QD wiring

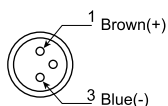

3 wire QD wiring

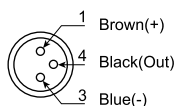

P8S-HHSP-011 and P8S-HISN-011 Sensors

P8S-HHSP-011 ↔ P8S-HISN-011

Description: Solid state magnetoresistive (MR) sensor
Function: PNP (N.O.) or NPN (N.O.)
Voltage supply range: 4.5 - 30 VDC
Current consumption: Max. 9 mA @ 24 V
Voltage drop: Max. 1.2 V
Max. switching current: 50 mA
Reverse polarity protection: Yes
Short circuit (transient) protection: Yes
Temperature range: -10°C to 70°C (14°F to 158°F)
Protection class: IP67
Response frequency: 1 kHz

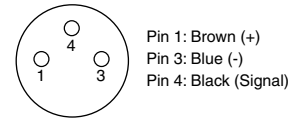

P8S-HHSP-011

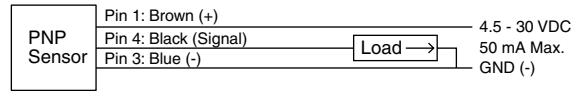

P8S-HISN-011

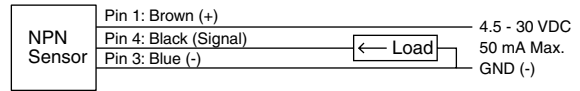

P8S-HHSP-017 and P8S-HHSN-017 Sensors

P8S-HHSP-017 ↔ P8S-HHSN-017

Description: Magnetoresistive 4mm Dovetail
Function: PNP (N.O.) or NPN (N.O.)
Voltage supply range: 4.5 - 28 VDC
Current consumption: Max. 10 mA @ 24 V
Voltage drop: Max. 0.5 V
Max. switching current: 100 mA
Reverse polarity protection: Yes
Short circuit (transient) protection: Yes
Temperature range: -10°C to 70°C (14°F to 158°F)
Protection class: IP67
Response frequency: 1 kHz
Hysteresis: <0.2 mm
Repeatability: <0.1 mm
Insulation resistance: Min 100 M OHM (Lead to case @ 500 VDC)
Withstand voltage: (Lead to case) 1000 VAC RMS for 1 min or 1500 VAC RMS for 2 sec

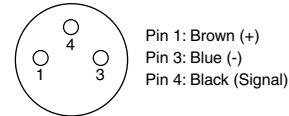

P8S-HHSP-017

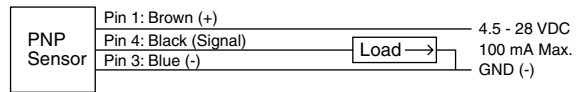

P8S-HHSN-017

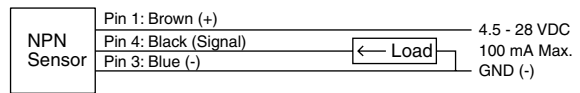

P8S-HISP-011 and P8S-HISN-011 Sensors

P8S-HISP-011 ↔ P8S-HISN-011

Description: Inductive 8mm proximity sensor
Connection: 3-pole quick disconnect
Function: PNP (N.O.) or NPN (N.O.)
Indicator: LED
Load current: 200 mA max.
Internal voltage drop: < 1 V
Current consumption: 15 mA max.
Operating voltage: 5 - 30 VDC
Reverse polarity protection: Yes
Response frequency: 800 - 1000 Hz
Relative humidity: 35 - 95%
Shielded design: Yes
Sensing range: 1.5 mm
Temperature range: -25°C to 7°C (-13°F to 45°F)
NEMA rating: 6
IEC rating: IP67
Ratings: CE, ISO 9001

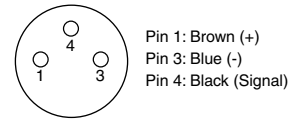

P8S-HISP-011

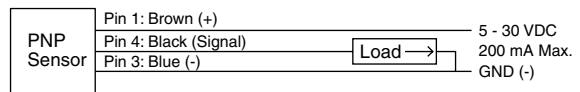

P8S-HISN-011

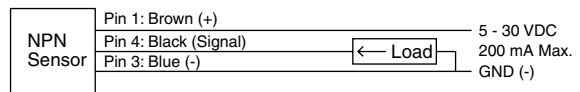

P8S-HISP-014 and P8S-HISN-014 Sensors

P8S-HISP-014 ↔ P8S-HISN-014

Description: Inductive 4mm proximity sensor
Connection: 3-pole quick disconnect
Function: PNP (N.O.) or NPN (N.O.)
Indicator: LED
Load current: 100 mA max.
Internal voltage drop: < 2.5 V
Current consumption: 18 mA
Operating voltage: 10 - 30 VDC
Reverse polarity protection: Yes
Response frequency: 5 kHz
Relative humidity: 35 - 95%
Shielded design: Yes
Sensing range: 1.0 mm
Temperature range: -25°C to 75°C (-13°F to 167°F)
NEMA rating: 6
IEC rating: IP67
Ratings: CE, ISO 9001

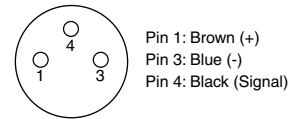

P8S-HISP-014

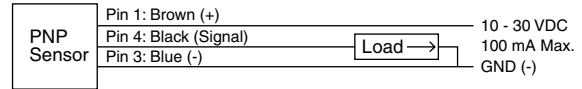

P8S-HISN-014

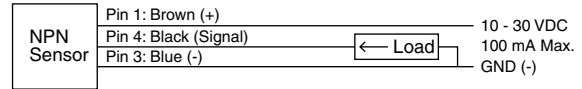

P8S-HISP-017 and P8S-HISN-017 Sensors

P8S-HISP-017 ↔ P8S-HISN-017

Description: Inductive 12mm proximity sensor
Connection: 4-pole quick disconnect
Function: PNP (N.O.) or NPN (N.O.)
Indicator: 360° LED
Load current: 200 mA max.
Internal voltage drop: < 2.0 V
Current consumption: 10 mA max.
Operating voltage: 10 - 30 VDC
Reverse polarity protection: Yes
Response frequency: 2 kHz
Shielded design: Yes
Sensing range: 4 mm
Temperature range: -25°C to 75°C (-13°F to 167°F)
NEMA rating: 6
IEC rating: IP67
Ratings: UL, CSA, CE

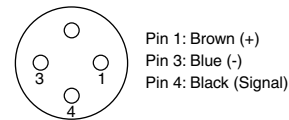

P8S-HISP-017

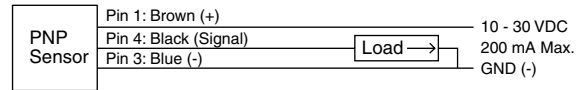

P8S-HISN-017

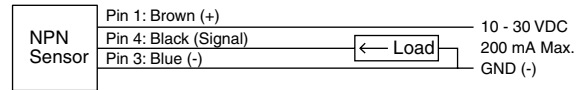



Male Connector

Thread (BSPP) / Tube	3mm	4mm (5/32 in)	6mm	8mm (5/16 in)	10mm	12mm
M3	68LF-3M-M3					
M5	68LF-3M-M5	68LF-4M-M5	68LF-6M-M5			
1/8		68LF-4M-2G	68LF-6M-2G	68LF-8M-2G		
1/4		68LF-4M-4G	68LF-6M-4G	68LF-8M-4G	68LF-10M-4G	68LF-12M-4G
3/8			68LF-6M-6G	68LF-8M-6G	68LF-10M-6G	68LF-12M-6G
1/2			68LF-6M-8G	68LF-8M-8G	68LF-10M-8G	68LF-12M-8G



Male Elbow
90 Degree Swivel

Thread (BSPP) / Tube	3mm	4mm (5/32 in)	6mm	8mm (5/16 in)	10mm	12mm
M3	369PLP-3M-M3	369PLP-4M-M3				
M5	369PLP-3M-M5	369PLP-4M-M5	369PLP-6M-M5			
1/8		369PLP-4M-2G	369PLP-6M-2G	369PLP-8M-2G		
1/4		369PLP-4M-4G	369PLP-6M-4G	369PLP-8M-4G	369PLP-10M-4G	369PLP-12M-4G
3/8			369PLP-6M-6G	369PLP-8M-6G	369PLP-10M-6G	369PLP-12M-6G
1/2			369PLP-6M-8G	369PLP-8M-8G	369PLP-10M-8G	369PLP-12M-8G



Flow Control
Right Angle

Thread (BSPP) / Tube	3mm	4mm (5/32 in)	6mm	8mm (5/16 in)	10mm	12mm
M3	FCM731-3M-M3	FCM731-4M-M3				
M5	FCM731-3M-M5	FCM731-4M-M5	FCM731-6M-M5			
1/8		FCM731-4M-2G	FCM731-6M-2G	FCM731-8M-2G		
1/4			FCM731-6M-4G	FCM731-8M-4G	FCC731-10M-4G	
3/8				FCM731-8M-6G	FCC731-10M-6G	FCC731-12M-6G
1/2						FCC731-12M-8G

Safety Guide for Selecting and Using Hydraulic, Pneumatic Cylinders and Their Accessories

WARNING: ⚠ FAILURE OF THE CYLINDER, ITS PARTS, ITS MOUNTING, ITS CONNECTIONS TO OTHER OBJECTS, OR ITS CONTROLS CAN RESULT IN:

- Unanticipated or uncontrolled movement of the cylinder or objects connected to it.
- Falling of the cylinder or objects held up by it.
- Fluid escaping from the cylinder, potentially at high velocity.

THESE EVENTS COULD CAUSE DEATH OR PERSONAL INJURY BY, FOR EXAMPLE, PERSONS FALLING FROM HIGH LOCATIONS, BEING CRUSHED OR STRUCK BY HEAVY OR FAST MOVING OBJECTS, BEING PUSHED INTO DANGEROUS EQUIPMENT OR SITUATIONS, OR SLIPPING ON ESCAPED FLUID.

Before selecting or using Parker (The Company) cylinders or related accessories, it is important that you read, understand and follow the following safety information. Training is advised before selecting and using The Company's products.

1.0 General Instructions

1.1 Scope – This safety guide provides instructions for selecting and using (including assembling, installing, and maintaining) cylinder products. This safety guide is a supplement to and is to be used with the specific Company publications for the specific cylinder products that are being considered for use.

1.2 Fail Safe – Cylinder products can and do fail without warning for many reasons. All systems and equipment should be designed in a fail-safe mode so that if the failure of a cylinder product occurs people and property won't be endangered.

1.3 Distribution – Provide a free copy of this safety guide to each person responsible for selecting or using cylinder products. Do not select or use The Company's cylinders without thoroughly reading and understanding this safety guide as well as the specific Company publications for the products considered or selected.

1.4 User Responsibility – Due to very wide variety of cylinder applications and cylinder operating conditions, The Company does not warrant that any particular cylinder is suitable for any specific application. This safety guide does not analyze all technical parameters that must be considered in selecting a product. The hydraulic and pneumatic cylinders outlined in this catalog are designed to The Company's design guidelines and do not necessarily meet the design guideline of other agencies such as American Bureau of Shipping, ASME Pressure Vessel Code etc. The user, through its own analysis and testing, is solely responsible for:

- Making the final selection of the cylinders and related accessories.
- Determining if the cylinders are required to meet specific design requirements as required by the Agency(s) or industry standards covering the design of the user's equipment.
- Assuring that the user's requirements are met, OSHA requirements are met, and safety guidelines from the applicable agencies such as but not limited to ANSI are followed and that the use presents no health or safety hazards.
- Providing all appropriate health and safety warnings on the equipment on which the cylinders are used.

1.5 Additional Questions – Call the appropriate Company technical service department if you have any questions or require any additional information. See the Company publication for the product being considered or used, or call 1-800-CPARKER, or go to www.parker.com, for telephone numbers of the appropriate technical service department.

2.0 Cylinder and Accessories Selection

2.1 Seals – Part of the process of selecting a cylinder is the selection of seal compounds. Before making this selection, consult the "seal information page(s)" of the publication for the series of cylinders of interest.

The application of cylinders may allow fluids such as cutting fluids, wash down fluids etc. to come in contact with the external area of the cylinder. These fluids may attack the piston rod wiper and or the primary seal and must be taken into account when selecting and specifying seal compounds.

Dynamic seals will wear. The rate of wear will depend on many operating factors. Wear can be rapid if a cylinder is mis-aligned or if the cylinder has been improperly serviced. The user must take seal wear into consideration in the application of cylinders.

2.2 Piston Rods – Possible consequences of piston rod failure or separation of the piston rod from the piston include, but are not limited to are:

- Piston rod and or attached load thrown off at high speed.
- High velocity fluid discharge.
- Piston rod extending when pressure is applied in the piston retract mode.

Piston rods or machine members attached to the piston rod may move suddenly and without warning as a consequence of other conditions occurring to the machine such as, but not limited to:

- Unexpected detachment of the machine member from the piston rod.
- Failure of the pressurized fluid delivery system (hoses, fittings, valves, pumps, compressors) which maintain cylinder position.
- Catastrophic cylinder seal failure leading to sudden loss of pressurized fluid.
- Failure of the machine control system.

Follow the recommendations of the "Piston Rod Selection Chart and Data" in the publication for the series of cylinders of interest. The suggested piston rod diameter in these charts must be followed in order to avoid piston rod buckling.

Piston rods are not normally designed to absorb bending moments or loads which are perpendicular to the axis of piston rod motion. These additional loads can cause the piston rod to fail. If these types of additional loads are expected to be imposed on the piston rod, their magnitude should be made known to our engineering department.

The cylinder user should always make sure that the piston rod is securely attached to the machine member.

On occasion cylinders are ordered with double rods (a piston rod extended from both ends of the cylinder). In some cases a stop is threaded on to one of the piston rods and used as an external stroke adjuster. On occasions spacers are attached to the machine member connected to the piston rod and also used as a stroke adjuster. In both cases the stops will create a pinch point and the user should consider appropriate use of guards. If these external stops are not perpendicular to the mating contact surface, or if debris is trapped between the contact surfaces, a bending moment will be placed on the piston rod, which can lead to piston rod failure. An external stop will also negate the effect of cushioning and will subject the piston rod to impact loading. Those two (2) conditions can cause piston rod failure. Internal stroke adjusters are available with and without cushions. The use of external stroke adjusters should be reviewed with our engineering department.

The piston rod to piston and the stud to piston rod threaded connections are secured with an anaerobic adhesive. The strength of the adhesive decreases with increasing temperature. Cylinders which can be exposed to temperatures above +250°F (+121°C) are to be ordered with a non studded piston rod and a pinned piston rod to rod joint.

2.3 Cushions – Cushions should be considered for cylinder applications when the piston velocity is expected to be over 4 inches/second.

Cylinder cushions are normally designed to absorb the energy of a linear applied load. A rotating mass has considerably more energy than the same mass moving in a linear mode. Cushioning for a rotating mass application should be reviewed by our engineering department.

2.4 Cylinder Mountings – Some cylinder mounting configurations may have certain limitations such as but not limited to minimum stroke for side or foot mounting cylinders or pressure de-ratings for certain mounts. Carefully review the catalog for these types of restrictions.

Always mount cylinders using the largest possible high tensile alloy steel socket head cap screws that can fit in the cylinder mounting holes and torque them to the manufacturer's recommendations for their size.

2.5 Port Fittings – Hydraulic cylinders applied with meter out or deceleration circuits are subject to intensified pressure at piston rod end.

The rod end pressure is approximately equal to:

$$\frac{\text{operating pressure} \times \text{effective cap end area}}{\text{effective rod end piston area}}$$

Contact your connector supplier for the pressure rating of individual connectors.

3.0 Cylinder and Accessories Installation and Mounting

3.1 Installation

3.1.1 – Cleanliness is an important consideration, and cylinders are shipped with the ports plugged to protect them from contaminants entering the ports. These plugs should not be removed until the piping is to be installed. Before making the connection to the cylinder ports, piping should be thoroughly cleaned to remove all chips or burrs which might have resulted from threading or flaring operations.

3.1.2 – Cylinders operating in an environment where air drying materials are present such as fast-drying chemicals, paint, or weld splatter, or other hazardous conditions such as excessive heat, should have shields installed to prevent damage to the piston rod and piston rod seals.

3.1.3 – Proper alignment of the cylinder piston rod and its mating component on the machine should be checked in both the extended and retracted positions. Improper alignment will result in excessive rod gland and/or cylinder bore wear. On fixed mounting cylinders attaching the piston rod while the rod is retracted will help in achieving proper alignment.

3.1.4 – Sometimes it may be necessary to rotate the piston rod in order to thread the piston rod into the machine member. This operation must always be done with zero pressure being applied to either side of the piston. Failure to follow this procedure may result in loosening the piston to rod-threaded connection. In some rare cases the turning of the piston rod may rotate a threaded piston rod gland and loosen it from the cylinder head. Confirm that this condition is not occurring. If it does, re-tighten the piston rod gland firmly against the cylinder head.

For double rod cylinders it is also important that when attaching or detaching the piston rod from the machine member that the torque be applied to the piston rod end of the cylinder that is directly attaching to the machine member with the opposite end unrestrained. If the design of the machine is such that only the rod end of the cylinder opposite to where the rod attaches to the machine member can be rotated, consult the factory for further instructions.

3.2 Mounting Recommendations

3.2.1 – Always mount cylinders using the largest possible high tensile alloy steel socket head screws that can fit in the cylinder mounting holes and torque them to the manufacturer's recommendations for their size.

3.2.2 – Side-Mounted Cylinders – In addition to the mounting bolts, cylinders of this type should be equipped with thrust keys or dowel pins located so as to resist the major load.

3.2.3 – Tie Rod Mounting – Cylinders with tie rod mountings are recommended for applications where mounting space is limited. The standard tie rod extension is shown as BB in dimension tables. Longer or shorter extensions can be supplied. Nuts used for this mounting style should be torqued to the same value as the tie rods for that bore size.

3.2.4 – Flange Mount Cylinders – The controlled diameter of the rod gland extension on head end flange mount cylinders can be used as a pilot to locate the cylinders in relation to the machine. After alignment has been obtained, the flanges may be drilled for pins or dowels to prevent shifting.

3.2.5 – Trunnion Mountings – Cylinders require lubricated bearing blocks with minimum bearing clearances. Bearing blocks should be carefully aligned and rigidly mounted so the trunnions will not be subjected to bending moments. The rod end should also be pivoted with the pivot pin in line and parallel to axis of the trunnion pins.

3.2.6 – Clevis Mountings – Cylinders should be pivoted at both ends with centerline of pins parallel to each other. After cylinder is mounted, be sure to check to assure that the cylinder is free to swing through its working arc without interference from other machine parts.

4.0 Cylinder and Accessories Maintenance, Troubleshooting and Replacement

4.1 Storage – At times cylinders are delivered before a customer is ready to install them and must be stored for a period of time. When storage is required the following procedures are recommended.

4.1.1 – Store the cylinders in an indoor area which has a dry, clean and noncorrosive atmosphere. Take care to protect the cylinder from both internal corrosion and external damage.

4.1.2 – Whenever possible cylinders should be stored in a vertical position (piston rod up). This will minimize corrosion due to possible condensation which could occur inside the cylinder. This will also minimize seal damage.

4.1.3 – Port protector plugs should be left in the cylinder until the time of installation.

4.1.4 – If a cylinder is stored full of hydraulic fluid, expansion of the fluid due to temperature changes must be considered. Installing a check valve with free flow out of the cylinder is one method.

4.1.5 – When cylinders are mounted on equipment that is stored outside for extended periods, exposed unpainted surfaces, e.g. piston rod, must be coated with a rust-inhibiting compound to prevent corrosion.

4.2 Cylinder Trouble Shooting

4.2.1 – External Leakage

4.2.1.1 – Rod seal leakage can generally be traced to worn or damaged seals. Examine the piston rod for dents, gouges or score marks, and replace piston rod if surface is rough.

Rod seal leakage could also be traced to gland wear. If clearance is excessive, replace rod bushing and seal. Rod seal leakage can also be traced to seal deterioration. If seals are soft or gummy or brittle, check compatibility of seal material with lubricant used if air cylinder, or operating fluid if hydraulic cylinder. Replace with seal material, which is compatible with these fluids. If the seals are hard or have lost elasticity, it is usually due to exposure to temperatures in excess of 165°F. (+74°C). Shield the cylinder from the heat source to limit temperature to 350°F. (+177°C.) and replace with fluorocarbon seals.

4.2.1.2 – Cylinder body seal leak can generally be traced to loose tie rods. Torque the tie rods to manufacturer's recommendation for that bore size.

Excessive pressure can also result in cylinder body seal leak. Determine maximum pressure to rated limits. Replace seals and retorqued tie rods as in paragraph above. Excessive pressure can also result in cylinder body seal leak. Determine if the pressure rating of the cylinder has been exceeded. If so, bring the operating pressure down to the rating of the cylinder and have the tie rods replaced.

Pinched or extruded cylinder body seal will also result in a leak. Replace cylinder body seal and retorqued as in paragraph above.

Cylinder body seal leakage due to loss of radial squeeze which shows up in the form of flat spots or due to wear on the O.D. or I.D. – Either of these are symptoms of normal wear due to high cycle rate or length of service. Replace seals as per paragraph above.

4.2.2 – Internal Leakage

4.2.2.1 – Piston seal leak (by-pass) 1 to 3 cubic inches per minute leakage is considered normal for piston ring construction. Virtually no static leak with lipseal type seals on piston should be expected. Piston seal wear is a usual cause of piston seal leakage. Replace seals as required.

4.2.2.2 – With lipseal type piston seals excessive back pressure due to over-adjustment of speed control valves could be a direct cause of rapid seal wear. Contamination in a hydraulic system can result in a scored cylinder bore, resulting in rapid seal wear. In either case, replace piston seals as required.

4.2.2.3 – What appears to be piston seal leak, evidenced by the fact that the cylinder drifts, is not always traceable to the piston. To make sure, it is suggested that one side of the cylinder piston be pressurized and the fluid line at the opposite port be disconnected. Observe leakage. If none is evident, seek the cause of cylinder drift in other component parts in the circuit.

4.2.3 – Cylinder Fails to Move the Load

4.2.3.1 – Pneumatic or hydraulic pressure is too low. Check the pressure at the cylinder to make sure it is to circuit requirements.

4.2.3.2 – Piston Seal Leak – Operate the valve to cycle the cylinder and observe fluid flow at valve exhaust ports at end of cylinder stroke. Replace piston seals if flow is excessive.

4.2.3.3 – Cylinder is undersized for the load – Replace cylinder with one of a larger bore size.

4.3 Erratic or Chatter Operation

4.3.1 – Excessive friction at rod gland or piston bearing due to load misalignment – Correct cylinder-to-load alignment.

4.3.2 – Cylinder sized too close to load requirements – Reduce load or install larger cylinder.

4.3.3 – Erratic operation could be traced to the difference between static and kinetic friction. Install speed control valves to provide a back pressure to control the stroke.

4.4 Cylinder Modifications, Repairs, or Failed Component – Cylinders as shipped from the factory are not to be disassembled and or modified. If cylinders require modifications, these modifications must be done at company locations or by The Company's certified facilities. The Cylinder Division Engineering Department must be notified in the event of a mechanical fracture or permanent deformation of any cylinder component (excluding seals). This includes a broken piston rod, tie rod, mounting accessory or any other cylinder component. The notification should include all operation and application details. This information will be used to provide an engineered repair that will prevent recurrence of the failure.

It is allowed to disassemble cylinders for the purpose of replacing seals or seal assemblies. However, this work must be done by strictly following all the instructions provided with the seal kits.

The items described in this document and other documents and descriptions provided by Parker Hannifin Corporation, its subsidiaries and its authorized distributors ("Seller") are hereby offered for sale at prices to be established by Seller. This offer and its acceptance by any customer ("Buyer") shall be governed by all of the following Terms and Conditions. Buyer's order for any item described in its document, when communicated to Seller verbally, or in writing, shall constitute acceptance of this offer. All goods or work described will be referred to as "Products".

1. Terms and Conditions. Seller's willingness to offer Products, or accept an order for Products, to or from Buyer is subject to these Terms and Conditions or any newer version of the terms and conditions found on-line at www.parker.com/saleterms/. Seller objects to any contrary or additional terms or conditions of Buyer's order or any other document issued by Buyer.

2. Price Adjustments; Payments. Prices stated on Seller's quote or other documentation offered by Seller are valid for 30 days, and do not include any sales, use, or other taxes unless specifically stated. Unless otherwise specified by Seller, all prices are F.C.A. Seller's facility (INCOTERMS 2010). Payment is subject to credit approval and is due 30 days from the date of invoice or such other term as required by Seller's Credit Department, after which Buyer shall pay interest on any unpaid invoices at the rate of 1.5% per month or the maximum allowable rate under applicable law.

3. Delivery Dates; Title and Risk; Shipment. All delivery dates are approximate and Seller shall not be responsible for any damages resulting from any delay. Regardless of the manner of shipment, title to any products and risk of loss or damage shall pass to Buyer upon placement of the products with the shipment carrier at Seller's facility. Unless otherwise stated, Seller may exercise its judgment in choosing the carrier and means of delivery. No deferment of shipment at Buyers' request beyond the respective dates indicated will be made except on terms that will indemnify, defend and hold Seller harmless against all loss and additional expense. Buyer shall be responsible for any additional shipping charges incurred by Seller due to Buyer's acts or omissions.

4. Warranty. Seller warrants that the Products sold hereunder shall be free from defects in material or workmanship for a period of twelve months from the date of delivery to Buyer or 2,000 hours of normal use, whichever occurs first. The prices charged for Seller's products are based upon the exclusive limited warranty stated above, and upon the following disclaimer: **DISCLAIMER OF WARRANTY: THIS WARRANTY COMPRISES THE SOLE AND ENTIRE WARRANTY PERTAINING TO PRODUCTS PROVIDED HEREUNDER. SELLER DISCLAIMS ALL OTHER WARRANTIES, EXPRESS AND IMPLIED, INCLUDING DESIGN, MERCHANTABILITY AND FITNESS FOR A PARTICULAR PURPOSE.**

5. Claims; Commencement of Actions. Buyer shall promptly inspect all Products upon delivery. No claims for shortages will be allowed unless reported to the Seller within 10 days of delivery. No other claims against Seller will be allowed unless asserted in writing within 30 days after delivery. Buyer shall notify Seller of any alleged breach of warranty within 30 days after the date the defect is or should have been discovered by Buyer. Any action based upon breach of this agreement or upon any other claim arising out of this sale (other than an action by Seller for an amount due on any invoice) must be commenced within 12 months from the date of the breach without regard to the date breach is discovered.

6. LIMITATION OF LIABILITY. UPON NOTIFICATION, SELLER WILL, AT ITS OPTION, REPAIR OR REPLACE A DEFECTIVE PRODUCT, OR REFUND THE PURCHASE PRICE. **IN NO EVENT SHALL SELLER BE LIABLE TO BUYER FOR ANY SPECIAL, INDIRECT, INCIDENTAL OR CONSEQUENTIAL DAMAGES ARISING OUT OF, OR AS THE RESULT OF, THE SALE, DELIVERY, NON-DELIVERY, SERVICING, USE OR LOSS OF USE OF THE PRODUCTS OR ANY PART THEREOF, OR FOR ANY CHARGES OR EXPENSES OF ANY NATURE INCURRED WITHOUT SELLER'S WRITTEN CONSENT, EVEN IF SELLER HAS BEEN NEGLIGENT, WHETHER IN CONTRACT, TORT OR OTHER LEGAL THEORY. IN NO EVENT SHALL SELLER'S LIABILITY UNDER ANY CLAIM MADE BY BUYER EXCEED THE PURCHASE PRICE OF THE PRODUCTS.**

7. User Responsibility. The user, through its own analysis and testing, is solely responsible for making the final selection of the system and Product and assuring that all performance, endurance, maintenance, safety and warning requirements of the application are met. The user must analyze all aspects of the application and follow applicable industry standards and Product information. If Seller provides Product or system options, the user is responsible for determining that such data and specifications are suitable and sufficient for all applications and reasonably foreseeable uses of the Products or systems.

8. Loss to Buyer's Property. Any designs, tools, patterns, materials, drawings, confidential information or equipment furnished by Buyer or any other items which become Buyer's property, may be considered obsolete and may be destroyed by Seller after two consecutive years have elapsed without Buyer ordering the items manufactured using such property. Seller shall not be responsible for any loss or damage to such property while it is in Seller's possession or control.

9. Special Tooling. A tooling charge may be imposed for any special tooling, including without limitation, dies, fixtures, molds and patterns, acquired to manufacture Products. Such special tooling shall be and remain Seller's property notwithstanding payment of any charges by Buyer. In no event will Buyer acquire any interest in apparatus belonging to Seller which is utilized in the manufacture of the Products, even if such apparatus has been specially converted or adapted for such manufacture and notwithstanding any charges paid by Buyer. Unless otherwise agreed, Seller shall have the right to alter, discard or otherwise dispose of any special tooling or other property in its sole discretion at any time.

10. Buyer's Obligation; Rights of Seller. To secure payment of all sums due or otherwise, Seller shall retain a security interest in the goods delivered and this agreement shall be deemed a Security Agreement under the Uniform Commercial Code. Buyer authorizes Seller as its attorney to execute and file on Buyer's behalf all documents Seller deems necessary to perfect its security interest.

11. Improper use and Indemnity. Buyer shall indemnify, defend, and hold Seller harmless from any claim, liability, damages, lawsuits, and costs (including attorney fees), whether for personal injury, property damage, patent, trademark or copyright

infringement or any other claim, brought by or incurred by Buyer, Buyer's employees, or any other person, arising out of: (a) improper selection, improper application or other misuse of Products purchased by Buyer from Seller; (b) any act or omission, negligent or otherwise, of Buyer; (c) Seller's use of patterns, plans, drawings, or specifications furnished by Buyer to manufacture Product; or (d) Buyer's failure to comply with these terms and conditions. Seller shall not indemnify Buyer under any circumstance except as otherwise provided.

12. Cancellations and Changes. Orders shall not be subject to cancellation or change by Buyer for any reason, except with Seller's written consent and upon terms that will indemnify, defend and hold Seller harmless against all direct, incidental and consequential loss or damage. Seller may change product features, specifications, designs and availability with notice to Buyer.

13. Limitation on Assignment. Buyer may not assign its rights or obligations under this agreement without the prior written consent of Seller.

14. Force Majeure. Seller does not assume the risk and shall not be liable for delay or failure to perform any of Seller's obligations by reason of circumstances beyond the reasonable control of Seller (hereinafter "Events of Force Majeure") Events of Force Majeure shall include without limitation: accidents, strikes or labor disputes, acts of any government or government agency, acts of nature, delays or failures in delivery from carriers or suppliers, shortages of materials, or any other cause beyond Seller's reasonable control.

15. Waiver and Severability. Failure to enforce any provision of this agreement will not waive that provision nor will any such failure prejudice Seller's right to enforce that provision in the future. Invalidation of any provision of this agreement by legislation or other rule of law shall not invalidate any other provision herein. The remaining provisions of this agreement will remain in full force and effect.

16. Termination. Seller may terminate this agreement for any reason and at any time by giving Buyer thirty (30) days written notice of termination. Seller may immediately terminate this agreement, in writing, if Buyer: (a) commits a breach of any provision of this agreement (b) appointments a trustee, receiver or custodian for all or any part of Buyer's property (c) files a petition for relief in bankruptcy on its own behalf, or by a third party (d) makes an assignment for the benefit of creditors, or (e) the dissolves or liquidates all or a majority of its assets.

17. Governing Law. This agreement and the sale and delivery of all Products hereunder shall be deemed to have taken place in and shall be governed and construed in accordance with the laws of the State of Ohio, as applicable to contracts executed and wholly performed therein and without regard to conflicts of laws principles. Buyer irrevocably agrees and consents to the exclusive jurisdiction and venue of the courts of Cuyahoga County, Ohio with respect to any dispute, controversy or claim arising out of or relating to this agreement.

18. Indemnity for Infringement of Intellectual Property Rights. Seller shall have no liability for infringement of any patents, trademarks, copyrights, trade dress, trade secrets or similar rights except as provided in this Section. Seller will defend and indemnify Buyer against allegations of infringement of U.S. patents, U.S. trademarks, copyrights, trade dress and trade secrets ("Intellectual Property Rights"). Seller will defend at its expense and will pay the cost of any settlement or damages awarded in an action brought against Buyer based on an allegation that a Product sold pursuant to this Agreement infringes the Intellectual Property Rights of a third party. Seller's obligation to defend and indemnify Buyer is contingent on Buyer notifying Seller within ten (10) days after Buyer becomes aware of such allegations of infringement, and Seller having sole control over the defense of any allegations or actions including all negotiations for settlement or compromise. If a Product is subject to a claim that it infringes the Intellectual Property Rights of a third party, Seller may, at its sole expense and option, procure for Buyer the right to continue using the Product, replace or modify the Product so as to make it noninfringing, or offer to accept return of the Product and return the purchase price less a reasonable allowance for depreciation. Notwithstanding the foregoing, Seller shall have no liability for claims of infringement based on information provided by Buyer, or directed to Products delivered hereunder for which the designs are specified in whole or part by Buyer, or infringements resulting from the modification, combination or use in a system of any Product sold hereunder. The foregoing provisions of this Section shall constitute Seller's sole and exclusive liability and Buyer's sole and exclusive remedy for infringement of Intellectual Property Rights.

19. Entire Agreement. This agreement contains the entire agreement between the Buyer and Seller and constitutes the final, complete and exclusive expression of the terms of sale. All prior or contemporaneous written or oral agreements or negotiations with respect to the subject matter are herein merged.

20. Compliance with Law, U. K. Bribery Act and U.S. Foreign Corrupt Practices Act. Buyer agrees to comply with all applicable laws and regulations, including both those of the United Kingdom and the United States of America, and of the country or countries of the Territory in which the Buyer may operate, including without limitation the U. K. Bribery Act, the U.S. Foreign Corrupt Practices Act ("FCPA") and the U.S. Anti-Kickback Act (the "Anti-Kickback Act"), and agrees to indemnify and hold harmless Seller from the consequences of any violation of such provisions by Buyer, its employees or agents. Buyer acknowledges that they are familiar with the provisions of the U. K. Bribery Act, the FCPA and the Anti-Kickback Act, and certifies that Buyer will adhere to the requirements thereof. In particular, Buyer represents and agrees that Buyer shall not make any payment or give anything of value, directly or indirectly to any governmental official, any foreign political party or official thereof, any candidate for foreign political office, or any commercial entity or person, for the purpose of influencing such person to purchase products or otherwise benefit the business of Seller.

Parker Hannifin Corporation
Pneumatic Division
135 Quadral Drive
Wadsworth, OH 44281 USA
Tel: 330 336 3511
Fax: 330 334 3335
Web site: www.parker.com/pneumatics

