



Lincoln installation components, accessories and lubrication fittings



MFP AUTOMATION ENGINEERING



LINCOLN

People, capabilities and systems to save money and increase productivity

Industry leader

Continually satisfying our customers with the world's best lubrication equipment and pumping systems has made Lincoln the largest and most successful company in our field. For nearly a century, companies have relied on our technical and quality leadership; our world-class manufacturing and customer service, and our vast network of distributors and support facilities.

Research and development

In order to provide the best worldwide and regional application solutions, Lincoln develops new products and systems at research and development facilities in the United States, Germany and India.

Providing solutions

Industrial customers in large processing plants, automotive manufacturing, pulp and paper mills, food and beverage and other manufacturing facilities can depend on solutions from Lincoln. For the toughest mobile applications, on the road or in the field, Lincoln protects heavy equipment used in mining, construction, agriculture and over-the-road trucking. In addition, Lincoln offers the best lubrication equipment to meet the needs of automotive service professionals.

Complete product line

Lincoln supplies automatic lubrication systems, pumps and pump stations and top quality lubrication equipment and accessories. Our quality systems in the United States and Germany are ISO 9001 registered and our fittings business is QS 9000 registered.

Worldwide support

With five technical support centers on three continents, and a network of distributors supported by regional sales and service offices, our customers can always draw on our worldwide resources.



Lubrication Fittings & Accessories:

<i>Introduction</i>	2
<i>Threaded Fittings</i>	4
<i>Spin-Drive Fittings</i>	7
<i>Drive-Type Fittings</i>	8
<i>Flush-Type Fittings</i>	8
<i>Stainless Steel Fittings</i>	9
<i>Special Purpose Fittings</i>	10
<i>Elbows and Plugs</i>	11
<i>Design Tips</i>	12
<i>Remote Lube Fitting Systems</i>	14
<i>Carton Quantities</i>	20

Installation Components:

<i>Tubing</i>	22
<i>Clamps and Screws</i>	23
<i>Heavy-Duty Tube Fittings</i>	24
<i>Standard-Duty Tube Fittings</i>	26
<i>Threaded Sleeve Tube Fittings</i>	28
<i>Snap-On Coupler Tube Fittings</i>	29
<i>Tubing Adapters</i>	30
<i>Supply Line and Material Hose</i>	31
<i>Feed Line Hose</i>	32
<i>Bulk Feed Line Hose and Fittings</i>	33
<i>Heavy-Duty Air Line Quick Disconnects</i>	34
<i>Pipe Fittings</i>	35
<i>Accessories</i>	38
<i>AirCare Air Preparation Systems</i>	41
<i>Decimal Equivalents</i>	51
<i>Numerical Index</i>	52

Introduction

A Lincoln lubrication fitting can be used for all of your lubrication needs. Our fittings are used in the automobile, agricultural, marine, truck, construction equipment and machine manufacturing industries.

Lincoln offers a full line of lubrication fittings to meet the manufacturing requirements of today's industries. Our line consists of common threaded, thread-forming, drive-type, stainless steel, pressure relief, standard button head and vent fittings.



Common Threaded Fitting



Thread Forming Fitting



Drive-Type Fitting



Stainless Steel Fitting



Pressure Relief Fitting



Standard Button Head Fitting



Vent Fitting

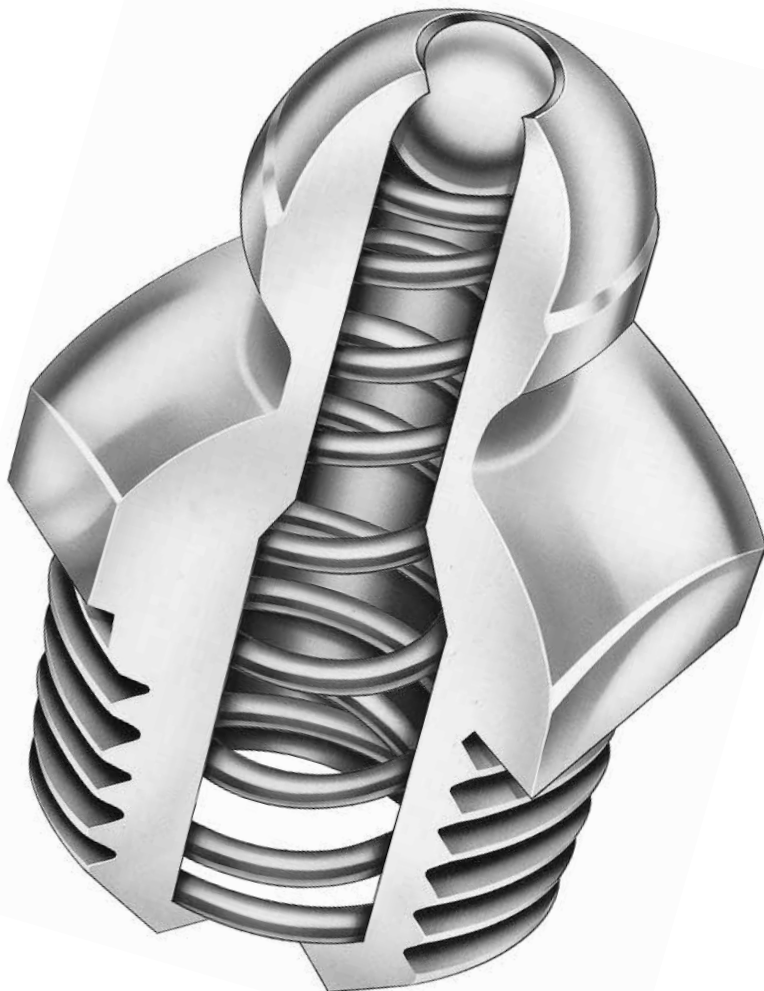

The ball check in the head of the fitting prevents dirt and grit from getting into the bearing. The fittings can be wiped clean without forcing foreign material into the fitting and the bearing. The true spherical contour of the fitting head provides a natural ball and socket joint between the fitting head and any commercial hydraulic coupler for a wide-angularity of contact, and a tight metal-to-metal seal. The internal spring on the fittings is tempered with music wire, coiled so that it cannot be compressed to restrict the flow of heavy lubricants, or forced out of the body under normal pressures. The fittings have a specially formed lip at the fitting base that locks the spring and ball securely in place.

Remote Lube Fitting Systems: To easily reach hidden, inaccessible or hazardous bearings

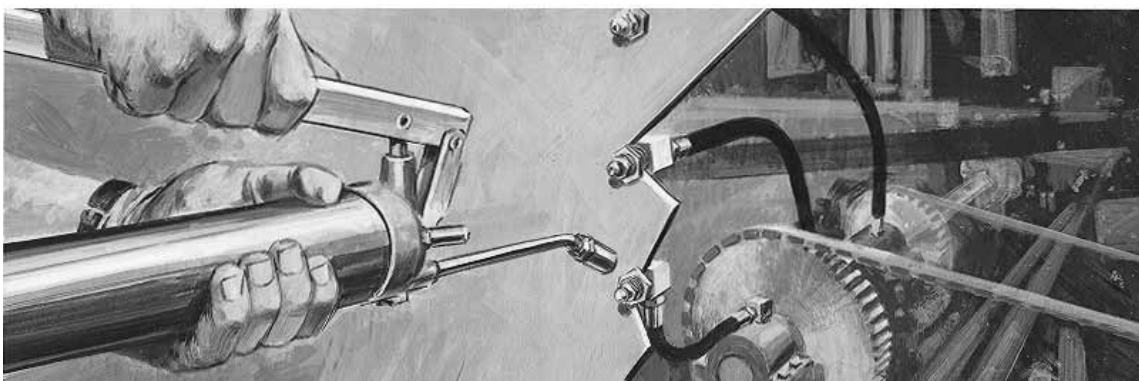
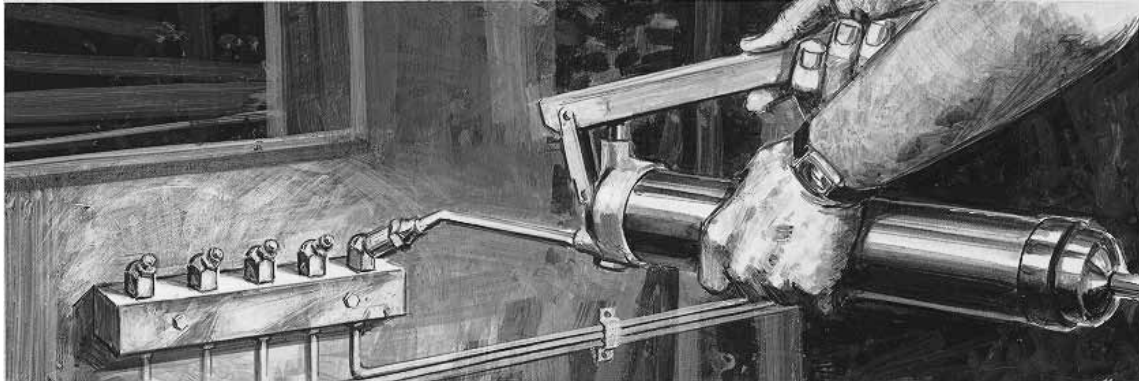

Hard-to-reach lubrication fittings present a major maintenance problem for the proper care of all types of machinery. Hidden or guarded lubrication fittings can lead to production downtime, higher operating and maintenance costs and the risk of personal injury to operators and employees—all directly traceable to poor lubrication fitting access.

How do you eliminate these problems?

Lincoln's Remote Lube Fitting Systems

Benefits

- Easy access to lubrication fittings
- Easier, quicker and safer lubrication
- Assures that all bearings are lubricated
- Bearings can be safely lubricated while machine is operating
- Reaches hidden, inaccessible or hazardous bearings

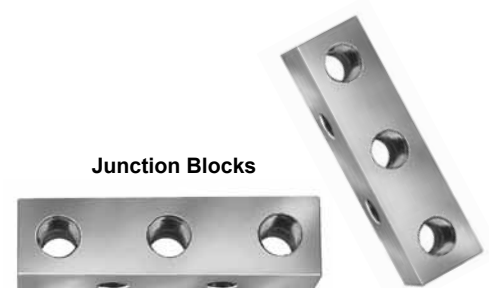

Lubrication Fittings & Accessories

Threaded Fittings



On the straight and angle fittings, the ball check end or the greasing end is heat treated. The spin-drive and drive-type angle fittings are entirely heat treated. All fittings are zinc plated and have a supplemental coating.

1/4" - 28 Thread (Straight & Taper)

This type of thread is used mostly on cars and light trucks. The SAE-LT is a thread that conforms to the Society of Automotive Engineers lubrication fittings thread specification.



No. 5010
*No. 5010-1
1/4" -28 Taper Thd.
(SAE-LT)



No. 5527
1/4" -28 U.N.F.
2A Thd.



No. 5013
1/4" -28 Taper Thd.
(SAE-LT)



No. 5014
1/4" -28 Taper Thd.
(SAE-LT)



No. 5210
1/4" -28 Taper Thd.
(SAE-LT)



No. 5410
1/4" -28 Taper Thd.
(SAE-LT)



No. 700396
1/4" -28 Taper Thd.
(SAE-LT)

Part No.	A in./mm	B in./mm	C in./mm	D in./mm	E	F in./mm	G in./mm
5527	1 ⁷ / ₃₂ / 14.0	1 ¹ / ₆₄ / 4.4	9 ³² / 7.1	.250 / 6.4	—	—	—
5010	1 ⁷ / ₃₂ / 13.5	3 ¹⁶ / 4.8	5 ¹⁶ / 7.9	.260 / 6.6	—	—	—
* 5010-1	3 ⁵ / ₆₄ / 13.9	7 ³² / 5.6	5 ¹⁶ / 7.9	.260 / 6.6	—	—	—
5013	1 ¹ / ₁₆ / 17.5	2 ³ / ₆₄ / 9.1	5 ¹⁶ / 7.9	.260 / 6.6	—	—	—
5014	1 ⁵ / ₁₆ / 23.8	3 ⁹ / ₆₄ / 15.5	5 ¹⁶ / 7.9	.260 / 6.6	—	—	—
5210	1 ³ / ₁₆ / 20.6	1 ³ / ₆₄ / 5.1	3 ⁸ / 9.5	.260 / 6.6	45°	3 ⁷ / ₆₄ / 14.7	2 ⁷ / ₆₄ / 10.7
5410	3 ⁴ / 19.1	3 ¹⁶ / 4.8	3 ⁸ / 9.5	.260 / 6.6	90°	2 ¹ / ₃₂ / 16.7	1 ⁵ / ₃₂ / 11.9
700396	2 ⁵ / ₃₂ / 19.8	1 ⁹ / ₆₄ / 7.5	3 ⁸ / 9.5	.260 / 6.6	65°	2 ¹ / ₃₂ / 16.7	1 ⁵ / ₃₂ / 11.9

* Not illustrated. Same as No. 5010 but without Ball Check.

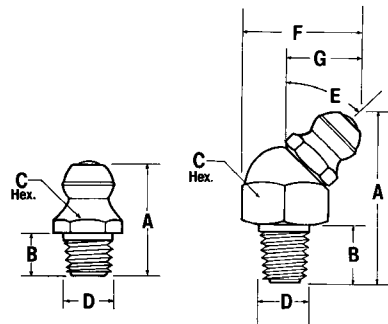

1/8" Pipe Thread

The 1/8" pipe threaded fittings are constructed for additional strength. This type of fitting is popular for use in the construction and agricultural industry and large industrial machinery.



No. 5000
1/8" P.T.F. Spec.
Extra Short



No. 5003
1/8" P.T.F.
Spec. Short



No. 5009
1/8" P.T.F.
Spec. Short



No. 5505
1/8" N.P.T.F.



No. 5200
1/8" P.T.F.
Spec. Short



No. 5300
1/8" P.T.F.
Spec. Short



No. 5308
1/8" P.T.F.
Spec. Short



No. 5400
1/8" P.T.F.
Spec. Short

Part No.	A in./mm	B in./mm	C in./mm	D in./mm	E	F in./mm	G in./mm
5000	2 1/32 / 16.7	19/64 / 7.5	7/16 / 11.1	.400 / 10.2	—	—	—
5003	1 1/4 / 31.8	25/32 / 19.8	7/16 / 11.1	.400 / 10.2	—	—	—
5009	2 5/8 / 66.7	2 5/32 / 54.8	7/16 / 11.1	.400 / 10.2	—	—	—
5505	1 / 25.4	5/16 / 7.9	1/2 / 12.7	.480 / 12.2	—	—	—
5200	5 7/64 / 22.6	19/64 / 7.5	7/16 / 11.1	.400 / 10.2	45°	4 1/64 / 16.3	2 7/64 / 10.7
5300	7/8 / 22.2	9/32 / 7.1	7/16 / 11.1	.400 / 10.2	65°	2 3/32 / 18.3	1/2 / 12.7
5308	1 7/32 / 31.0	9/16 / 14.3	7/16 / 11.1	.400 / 10.2	65°	2 3/32 / 18.3	1/2 / 12.7
5400	2 7/32 / 21.4	9/32 / 7.1	7/16 / 11.1	.400 / 10.2	90°	4 7/64 / 18.7	1/2 / 12.7

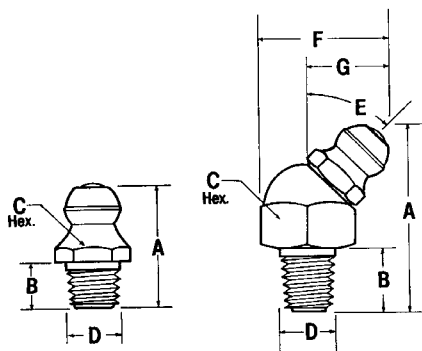



No. 5050
1/4" N.P.T.

1/4" Pipe Thread

Part No.	A in./mm	B in./mm	C in./mm	D in./mm	E in./mm	F in./mm	G in./mm
5050	53/64 / 21.0	3/8 / 9.5	9/16 / 14.3	.535 / 13.6	—	—	—
5350	1 1/32 / 26.2	3/8 / 9.5	9/16 / 14.3	.535 / 13.6	65°	13/16 / 20.6	7/32 / 13.5



No. 5350
1/4" N.P.T.F. Spec.
Extra Short

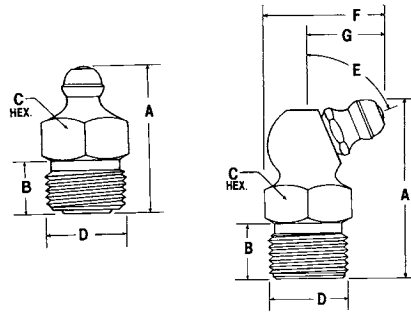

No. 5181
10 mm x 1



No. 5182
10 mm x 1



No. 5183
10 mm x 1

Metric Fittings – 6mm, 8mm, 10mm

Part No.	A in./mm	B in./mm	C mm	D mm	E	F in./mm	G in./mm
* 5175	33/64 / 13.1	13/64 / 5.2	7	6 mm x 1	—	—	—
* 5176	7/8 / 22.2	7/32 / 5.6	9		45°	37/64 / 14.7	25/64 / 9.9
* 5177	45/64 / 17.9	7/32 / 5.6	9		90°	3/4 / 19.1	9/16 / 14.3
* 5178	37/64 / 14.7	7/32 / 5.6	9	8 mm x 1	—	—	—
* 5179	7/8 / 22.2	7/32 / 5.6	9		45°	37/64 / 14.7	25/64 / 9.9
* 5180	45/64 / 17.9	7/32 / 5.6	9		90°	3/4 / 19.1	9/16 / 14.3
5181	39/64 / 15.5	7/32 / 5.6	11	10 mm x 1	—	—	—
5182	15/16 / 23.8	7/32 / 5.6	11		45°	41/64 / 16.3	27/64 / 10.7
5183	47/64 / 18.7	7/32 / 5.6	11		90°	45/64 / 17.9	1/2 / 12.7

* Not illustrated.

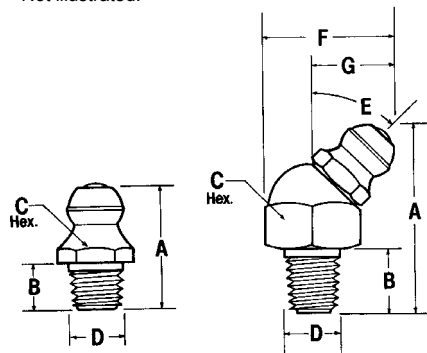

Spin-Drive

Spin-Drive (thread forming) fittings have special tapered drive threads for fast production line installation in untapped holes to save tapping cost. Spinning into the hole with a power wrench provides the most effective installation. Installation torque limits, to avoid stripping, should be established by test in the type of material in which production fittings are to be installed. Installation force causes a rearrangement of mating material to conform with the fitting thread contour creating a leak-tight permanent seal. Not recommended for heat treated parts. Fitting threads are heat treated to Rockwell 83-89 on the 15N scale.

For field servicing, Spin-Drive fittings may be replaced by any standard fitting having the same thread size or another Spin-Drive fitting.

Spin-Drive Fittings



No. 205010
1/4"-28 Spec. Taper Drive Th'd.



No. 205000
1/8" Pipe-Special Taper Drive Th'd.



No. 247235
1/8" Pipe-Special Taper Drive Th'd.



No. 205210
1/4" -28 Spec. Taper Drive Th'd.



No. 205200
1/8" Pipe-Special Taper Drive Th'd.



No. 205410
1/4" -28 Spec. Taper Drive Th'd.



No. 205400
1/8" Pipe-Special Taper Drive Th'd.

Part No.	A in./mm	B in./mm	C in./mm	D in./mm	E	F in./mm	G in./mm
205010	9/16 / 14.3	3/16 / 4.8	5/16 / 7.9	.256 / 6.5	—	—	—
205000	5/8 / 15.9	1/4 / 6.4	7/16 / 11.1	.396 / 10.1	—	—	—
247235	45/64 / 17.9	21/64 / 8.3	7/16 / 11.1	.400 / 10.2	—	—	—
205210	13/16 / 20.6	13/64 / 5.1	3/8 / 9.5	.256 / 6.5	45°	37/64 / 14.7	3/8 / 9.7
205200	21/32 / 21.4	13/64 / 5.2	7/16 / 11.1	.396 / 10.1	45°	21/32 / 16.7	27/64 / 10.7
205410	3/4 / 19.1	3/16 / 4.8	3/8 / 9.5	.256 / 6.5	90°	21/32 / 16.7	15/32 / 11.9
205400	49/64 / 19.3	13/64 / 5.2	7/16 / 11.1	.396 / 10.1	90°	47/64 / 18.7	33/64 / 13.0

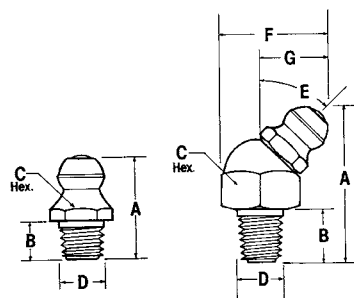

Drive-Type Fittings

Drive-type fittings are designed for fast production line installation in untapped holes to save thread tapping costs. Circumferential serrations on shank provide a hydraulic tight seal when fitting is installed properly. Cannot be used where high lubricant back pressures can be developed.

Hole sizes and shank dimensions are for reference use only. To determine optimum hole size, test applications should be conducted using the type of material into which the fitting is to be installed—steel, cast iron, brass, aluminum, etc. Production tolerances of hole size must be taken into consideration when test is conducted.

Drive-Type Fittings



No. 5033
For 3/16" / 4.8 mm
Dia. Hole



No. 5031
For 3/16" / 7.9 mm
Dia. Hole



No. 5036
For 3/16" / 9.5 mm
Dia. Hole



No. 5385
For 3/16" / 4.8 mm
Dia. Hole



No. 5318
For 1/4" / 6.4 mm
Dia. Hole



No. 700504
For 3/16" / 4.8 mm
Dia. Hole

Part No.	A in./mm	B in./mm	C in./mm	D in./mm	E	F in./mm	G in./mm
5033	33/64 / 13.1	15/64 / 6.0	5/16 / 7.9	.196 / 5.0	—	—	—
5031	35/64 / 13.9	1/4 / 6.4	3/8 / 9.5	.322 / 8.2	—	—	—
5036	5/8 / 15.9	1/4 / 6.4	7/16 / 11.1	.383 / 9.7	—	—	—
5385	23/32 / 18.3	7/32 / 5.6	3/8 / 9.5	.196 / 5.0	65°	1 1/16 / 17.5	1/2 / 12.7
5318	49/64 / 19.4	9/32 / 7.1	3/8 / 9.5	.259 / 6.6	65°	1 1/16 / 17.5	1/2 / 12.7
700504	1/2 / 12.7	3/16 / 4.8	5/16 / 7.9	.196 / 5.0	—	—	—

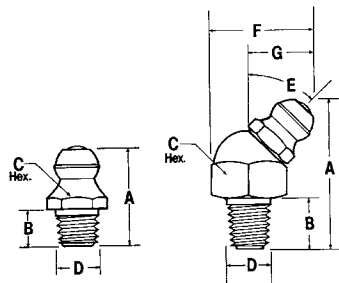

No. 700502
For 1/4" / 6.4 mm
Dia. Hole

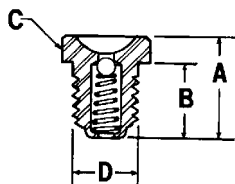

Flush Type Fittings

For use where installation of protruding fitting cannot be used. Can be used on shafts, pulleys, or other type of rotating bearing or parts.

Part No.	A in./mm	B in./mm	C in./mm	D in. / mm
700502	3/32 / 7.1	15/64 / 6.0	5/16 / 7.9 Dia.	.256 / 6.5

Stainless Steel Fittings

Select Lincoln stainless steel fittings for marine applications, food processing machinery, sewage disposal systems or any use where protection against corrosive elements is a design criteria. Stainless steel ball checks and springs are securely housed in passivated austenitic type 303 stainless steel bodies for maximum usable life and performance. To avoid use of inferior substitutes specify Lincoln Stainless Steel fittings by part number on your drawings.



No. 5010-9
1/4" -28 Taper Thd.
(SAE-LT)



No. 5000-9
1/8" P.T.F. Spec. Extra
Short



No. 5410-9
1/4" -28 Taper Thd.
(SAE-LT)



No. 5033-9
For 3/16"/4.8 mm
Dia. Hole

Stainless Steel Fittings

Part No.	A in./mm	B in./mm	C in./mm	D in./mm	E	F in./mm	G in./mm
5010-9	1 1/32 / 13.5	3/16 / 4.8	5/16 / 7.9 Hex.	.260 / 6.6	—	—	—
5000-9	4 1/64 / 16.3	9/32 / 7.1	7/16 / 11.1 Hex.	.400 / 10.2	—	—	—
5410-9	3/4 / 19.1	3/16 / 4.8	3/8 / 9.5 Hex.	.260 / 6.6	90°	2 1/32 / 16.7	1 1/32 / 11.9
5033-9	9/16 / 14.3	1/4 / 6.4	5/16 / 7.9 Dia.	.196 / 5.0	—	—	—

Max. 600°F (315°C)

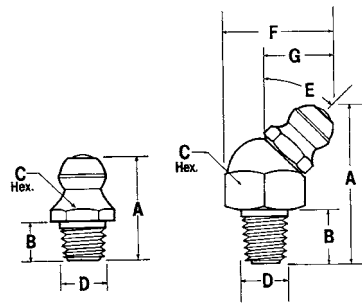

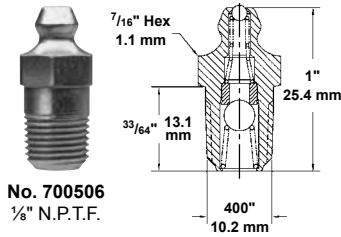

No. 700506
1/8" N.P.T.F.

Leakproof Fitting

Leakproof fittings are special purpose fittings for use in those applications where a positive seal is essential. A special steel ball check, brass insert seat and a surface ball check provide an effective seal. Designed for grease, medium and heavy oils, it withstands a back pressure up to 10,000 psi (690 bar).

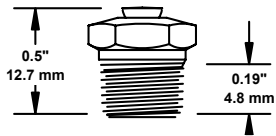

No. 5677
1/8" P.T.F. Spec. Short

Pressure Relief Valves

Use wherever control of oil or grease pressure is required. Releases pressure build up during equipment operation or when filling gear cases or bearing housings with pressure guns. Twin vent ports provide visual indication of pressure relief. Select valve with pressure range best suited to design application.

Part	Relief Pressure
5677	1 to 5 psig / .07 to .34 bars
5678	7½ to 15 psig / .52 to 1 bars
5679	15 to 25 psig / 1 to 1.7 bars
5680	45 to 80 psig / 3.1 to 5.5 bars

Operating parts are positioned internally for maximum protection against entry of dirt or valve damage. Ball check is located at base of valve body as close as possible to protected material. Not recommended to be used below the fluid level.

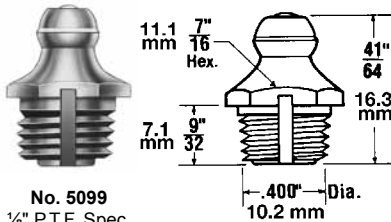

No. 5099
1/8" P.T.F. Spec. Extra Short

Safety Vent Fitting

Required for use in those applications where a build up of pressure in the bearing is undesirable or damaging. A vent slot cut vertical to the threads provides an air escape during bearing fill and when grease appears serves as a bearing fill indicator. Vent slot restriction permits bearing fill without build up of prohibitive pressure.

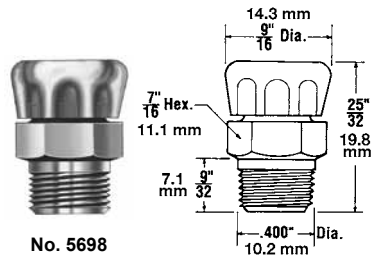

No. 5698
1/8" P.T.F. Spec. Short

Atmospheric Vent

For use on differentials, transmissions and gear boxes. It allows air to escape and enter as the internal pressure increases or decreases. The cap prevents dirt from entering. Must be installed above the normal level of fluid.



No. 5701
1/8" N.P.T.F.



No. 5706
1/4" N.P.T.F.

Button Head Fittings

Lincoln standard button head fittings (5/8" diameter head) are designed for use where volume flow of lubricant is required, such as bearings on earth moving equipment, conveyors and mining machinery. Heat treated and zinc plated for long service life.

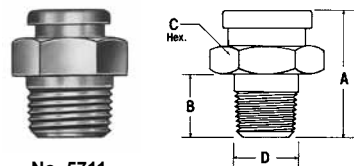

No. 5711
3/8" N.P.T.F.

Part No.	A in./mm	B in./mm	C in./mm	D in./mm
5701	3/4 / 19.1	23/64 / 9.1	5/8 / 15.9	.405 / 10.3
5706	27/32 / 21.4	7/16 / 11.1	5/8 / 15.9	.540 / 13.7
5711	1 1/16 / 27.0	37/64 / 14.7	3/4 / 19.1	.675 / 17.1

Button head coupler needed: 81458
Adapter: 10460
Gasket: 31138

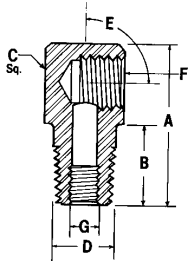

Street Elbows

Part No.	Style	A in./mm	B in./mm	C in./mm	D in./mm	E	F	G in./mm
20026	1	1 ³ / ₁₆ / 20.6	5 ¹ / ₁₆ / 7.9	1/2 / 12.7 Sq.	1/4-28 Taper	90°	1/8 PTF	—
247616	2	1 ¹ / ₁₆ / 27	1 ⁷ / ₃₂ / 13.5	1/2 / 12.7 Sq.	1/4-28 Taper	45°	1/8 PTF	—
20028	2	1 / 25.4	1 ⁵ / ₃₂ / 11.9	1/2 / 12.7 Sq.	1/8 PTF	45°	1/8 PTF	—
20031	1	1 ³ / ₁₆ / 20.6	9 ³ / ₃₂ / 7.1	1/2 / 12.7 Sq.	1/8 PTF	90°	1/8 PTF	—
20029	1	1 / 25.4	1 ⁵ / ₃₂ / 11.9	1/2 / 12.7 Sq.	1/8 PTF	90°	1/8 PTF	—
13155	2	1 / 25.4	3/8 / 9.5	1/2 / 12.7 Sq.	1/8 NPSM	90°	1/8 NPTF	1/4-28 UNF
13129	1	1 1/2 / 38.1	7/8 / 22.2	5/8 / 5.9 Sq.	1/8 NPTF	90°	1/8 NPTF	—

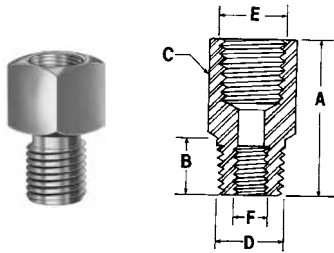

Adapters

Part No.	A in./mm	B in./mm	C in./mm	D	E	F
20024	7/8 / 22.2	5/16 / 7.9	1/2 / 12.7 Hex.	1/2" / 12.7 mm	1/8 NPSF	—
10182	1 ⁵ / ₁₆ / 23.8	3/8 / 9.5	9/16 / 14.3 Hex.	1/8 NPTF	1/8 NPTF	—
13154	7/8 / 22.2	3/8 / 9.5	1/2 / 12.7 Sq.	3/16" / 4.8 mm	1/8 NPTF	1/4-28 UNF
14054	7/8 / 22.2	7/16 / 11.1	1/2 / 12.7 Sq.	1/4" / 6.4 mm	1/8 NPTF	1/4-28 UNF

Plugs



No. 12511
1/8" P.T.F. Spec. Extra Short

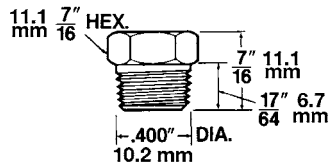

No. 700337
1/4"-28 Spec. Taper Drive Th'd.

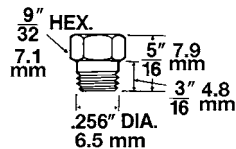



Fitting Installation and Removal Tools

Model 11485

For use to install straight drive-type fittings into untapped holes.



Model 11509

For use to install angle drive-type fittings into untapped holes.



Easy Out Tool

Combination tool for removing worn or broken fittings and retapping holes for new fitting installation, two models available:

Model G904

For tapping $\frac{1}{4}$ " -28 threads and removal of both $\frac{3}{8}$ " and $\frac{5}{16}$ " Hex, straight or angle fittings.

Model G905

For tapping $\frac{1}{8}$ " NPT threads and removal of both $\frac{7}{16}$ " Hex, straight or angle fittings.

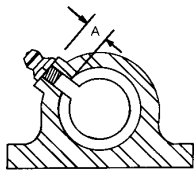

Depth of Engagement

When selecting a lubrication fitting, either straight, angle, standard thread, spin-drive or straight drive, be sure to measure engagement depth "A," taking manufacturing tolerance into consideration. Then select fitting with thread length or drive shank length that will not penetrate bearing material or rest against rotating member.

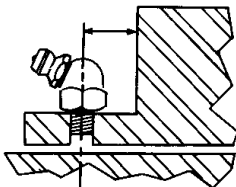

Turning Radius

The turning radius is given for all angle fittings shown in this manual. Be sure that this is taken into consideration during initial machine design and then select a fitting with a turning radius that will permit easy production line installation.

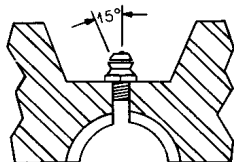

Deep Set Fittings

Deep set fittings are sometimes necessary in machine design. When required, make sure sufficient clearance is provided for easy disengagement of hydraulic coupler.

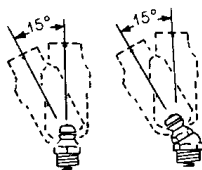

Angularity of Contact

Lincoln hydraulic couplers and fittings are designed to provide a hydraulic seal at any coupler angle up to 15° . Movement beyond this angle will cause coupler to disengage.

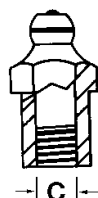
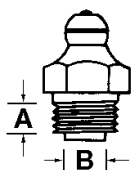

Determination of Pipe Thread Sizes

Nominal Pipe Thread Size	Threads Per Inch	Major Dia. B or C in. / mm	Nominal Engagement for tight Joint A in. / mm
1/8"	27	.405 / 10.3	1/4 / 6.4
1/4"	18	.540 / 13.7	3/8 / 9.5
3/8"	18	.675 / 17.1	3/8 / 9.5
1/2"	14	.840 / 21.3	1/2 / 12.7
3/4"	14	1.050 / 26.7	5/16 / 14.3
1"	11 1/2	1.315 / 33.4	11/16 / 17.5

Drill Size Selection

Fitting Thread Size	Tap Drill Selection for Standard Thread Fitting	Drilling Size Selection for Spin-Drive Fittings
1/4" -28	#3 (for soft metal, use #5)	"A" - .234" / 5.9mm Dia. *
5/16" -32	5/32" / 7.1mm (for soft metal, use "J")	-
1/8" Pipe	11/32" / 8.7mm (for soft metal, use "R")	3/8" - .375" / 9.5mm Dia. *
1/4" Pipe	7/16" / 11.1mm	-

* Drill sizes given are nominal and may vary with different types of material. For maximum effectiveness, test applications should be conducted using the type of material into which the fitting is to be installed (steel, cast iron, brass, aluminum, etc.). Production tolerances of hole must be taken into consideration when conducting test.

Lubrication Fitting Thread Symbols

The identification symbols and their meaning which have been adopted for the various threads used in the manufacture of lubrication fittings are given below:

Symbol	Meaning
NPT	American Standard Taper Pipe Thread
NPTF	Dryseal American Standard Taper Pipe Thread
PTF	Same as NPTF except full thread length has been shortened by one thread on small end of thread—also designated as PTF—SAE Short
PTF Special Short	Same as PTF Short except one full thread has been shortened from large end of thread
PTF Special Extra Short	Same as PTF Short except two full threads have been shortened from large end of thread
NPSF	Dryseal American Fuel Internal Straight Pipe Thread
NPSI	Dryseal American Intermediate Internal Straight Pipe Thread
NPSM	American Standard Straight Mechanical Pipe Thread
1/4" -28 Taper Thread (SAE-LT)	Thread has a 3/4" taper per foot and a pitch diameter of .2257/.2224 at small end. The mating tapped hole is 1/4" -28 UNF 3B straight thread. Tap drill must not exceed .215" diameter.
1/4" -28 Special Taper Drive Thread	Thread Forming-Forms thread in mating part during installation—when removed can be replaced by standard 1/4" -28 taper thread (SAE-LT) fitting.
1/8" Pipe Special Taper Drive Thread	Thread Forming-Forms thread in mating part during installation—when removed can be replaced by standard 1/8" -27 PTF series fitting.

Symbol	Designation	Symbol	Designation
N	American Standard	S	Straight
P	Pipe	M	Mechanical
T	Taper	I	Intermediate
F	Fuel	LT	Lubrication Thread

Lubrication Fittings & Accessories

Remote Lube Fitting Systems



Hard-to-reach lubrication fittings present a major maintenance problem for the proper care of all types of machinery. Hidden or guarded lubrication fittings can mean production downtime, higher operating and maintenance costs and risk of personal injury to operators and employees—all directly traceable to poor lubrication fitting access. How do you eliminate these problems? Lincoln's Remote Lube Fitting Systems benefit you by providing easy access to lubrication fittings; lubrication is easier, quicker and safer; assures all bearings will be lubricated—and can be safely lubricated while machine is operating; and finally, it's possible to reach hidden, inaccessible or hazardous bearings.



Junction Blocks

Junction block surface mount systems are used to bring multiple lubrication points to a common, easily accessible location. The junction blocks provide a means for coupling lubricant feed lines to bearings with lubrication fittings. They are available in three basic design groups and may be mounted in multiple units to meet all application requirements.

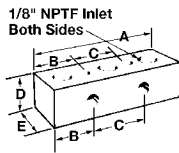

No. 13147

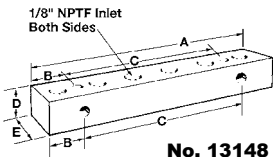

No. 13148

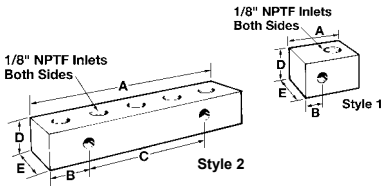

Style 1

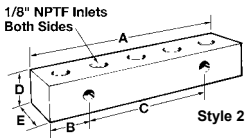

Style 2

Group I

Have $1\frac{1}{32}$ " diameter mounting holes at 90° intervals, for use with $\frac{5}{16}$ " diameter mounting bolts. This permits horizontal or vertical positioning of lubricant inlet passages.

Part No.	No. of Inlets	A in./mm	B in./mm	C in./mm	D in./mm	E in./mm
13147	3	2 $\frac{3}{4}$ / 69.9	$\frac{7}{8}$ / 22.2	1 / 25.4	$\frac{3}{4}$ / 19.1	$\frac{3}{4}$ / 19.1
13148	6	5 $\frac{3}{4}$ / 146.1	$\frac{7}{8}$ / 22.2	4 / 101.6	$\frac{3}{4}$ / 19.1	$\frac{3}{4}$ / 19.1

Group II

Have $\frac{9}{32}$ " diameter mounting holes for use with $\frac{1}{4}$ " diameter mounting bolts. Mounting holes are perpendicular to inlet passages permitting vertical positioning only.

Group II without Fitting Part No.	Style	No. of Inlets	A in./mm	B in./mm	C in./mm	D in./mm	E in./mm
14570	1	1	1 $\frac{1}{4}$ / 31.8	$\frac{3}{8}$ / 9.5	—	$\frac{3}{4}$ / 19.1	$\frac{3}{4}$ / 19.1
14562	1	2	1 $\frac{3}{4}$ / 44.5	$\frac{7}{8}$ / 22.2	—	$\frac{3}{4}$ / 19.1	$\frac{3}{4}$ / 19.1
14771	2	3	2 $\frac{3}{4}$ / 69.9	$\frac{7}{8}$ / 22.2	1 / 25.4	$\frac{3}{4}$ / 19.1	$\frac{3}{4}$ / 19.1
14563	2	4	3 $\frac{3}{4}$ / 95.3	$\frac{7}{8}$ / 22.2	2 / 50.8	$\frac{3}{4}$ / 19.1	$\frac{3}{4}$ / 19.1
14564	2	5	4 $\frac{3}{4}$ / 120.7	$\frac{7}{8}$ / 22.2	3 / 76.2	$\frac{3}{4}$ / 19.1	$\frac{3}{4}$ / 19.1
14772	2	6	5 $\frac{3}{4}$ / 146.1	$\frac{7}{8}$ / 22.2	4 / 101.6	$\frac{3}{4}$ / 19.1	$\frac{3}{4}$ / 19.1



Mounting Bolts and Nuts

Part No.	A in./mm	B in./mm	C in./mm
50057	¼"-20	1½ / 38.1	¾ / 19.1

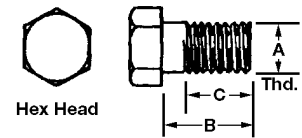

Part No.	A in./mm	B in./mm	C in./mm
51304	¼"-20	⅞ / 5.6	⅞ / 11.1
51026	⅝"-18	1⅞ / 6.7	½ / 12.7

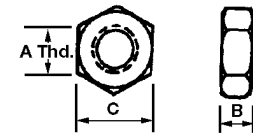

Accessories

Supply and Feed Line Hose ⅛" ID



Part No.	Alvania #2 Grade Grease Filled Coils	Minimum Burst	Max. Working Pressure	Minimum Bending	Hose Construction
241286	26 ft. / 7.9 M	10,000 psig 690 bar	4,000 psig 276 bar	3½" 88.9 mm	Nylon Tube, Dacron Braid, Polyurethane Cvr
241287	35 ft. / 10.7 M				
241288	40 ft. / 12.2 M				
252717	200 ft. / 61 M non grease filled				

Note: Use with hose ends No. 241289 or No. 246002. Temperature range: -40° F to 212° F.

Feed Line Nylon Tubing



Part No.	Description	O.D.	Wall Thickness	Burst Pressure	Working Pressure	Minimum Bending Radius	Working Temp.
247022	500 ft./152.4 M coil non-grease filled	¼" 6.4 mm	.050" 1.3 mm	2500 psig 172 bar	625 psig 42.5 bar	.875 / 22.2	-65°F to +150°F -54°C to +65°C
242025	25 ft. / 7.6 M coil grease filled						
242050	50 ft. / 15.2 M coil grease filled						
62357	100 ft./30.5 M coil non-grease filled						
274047	25 ft. / 7.6 M coil grease filled		.062" 1.6 mm	2000 psig 138 bar	500 psig 34.5 bar	0.5 / 12.7	-65°F to +200°F -54°C to +93°C
274048	50 ft. / 15.2 M coil grease filled						
274049	100 ft./30.5 M coil non-grease filled						
274050	500 ft./152.4 M coil non-grease filled						

Steel Tubing



Part No.	Description	Max. Working Pressure
62175	⅛" OD x .020" wall 25' coil 3.2mm OD x .5mm wall 7.6m coil	4400 psig 300 bar
62176	¼" OD x .028" wall 25' coil 6.4 mm OD x .7mm wall 7.6m coil	2800 psig 190 bar

Installation Tools



Plastic Tube & Hose Cutter
Part No. 226-12508-5
 Replacement Blade
Part No. 226-13095-7



Hose Ends for 1/8" I.D. Hose

Part No.	Description
241289	1/8" NPT swedge on hose stud (Requires swedging tool)
246002	1/8" NPT field installable hose coupling (swedging tool not required)

Installation Tools



Hose Ends for Use with Quickline Fittings

Part No.	Description
272394	Hose stud, 90° (to be used with 272427)
272401	Hose stud, straight (to be used with 272427)
272427	Threaded sleeve
274238	Stainless steel hose stud sleeve
274239	Stainless steel straight hose

Hose End Connecting Tools

Part No.	Description
274062	Hand vise for quick connect and reusable hose ends

Bulkhead Connectors

Part No.	Style	A	B	C	D
13154	1	1/8" PTF	1/2" / 12.7 mm	1/4" -28	3/16" / 4.8 mm
14054	1	1/8" PTF	1/2" / 12.7 mm	1/4" -28	1/4" / 6.4 mm
13155	2	1/8" PTF	1/2" / 12.7 mm	1/4" -28	3/16" / 4.8 mm
51055	Lock Nut 1/8" N.P.S.M. thread				

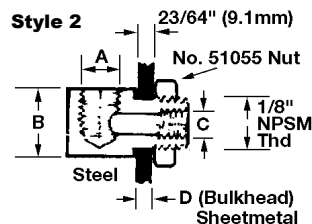
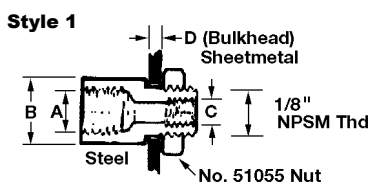
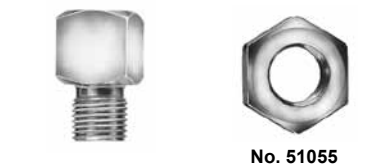

Adapter Union

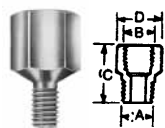

Part No.	A	B	C	D
20024	1/4" -28 THD	1/8" NPSF	7/8" / 22.2mm	1/2" / 12.7 mm
67132	3/8" NPT	1/8" NPT	3/4" / 19.1mm	1 1/16" / 17.5mm Hex
20011	3/8" NPT	1/4" NPT	3/4" / 19.1mm	3/4" / 19.1mm Hex
273482	8 mm x 1.0	1/8" NPT	0.96" / 24.4mm	9/16" / 14.2mm

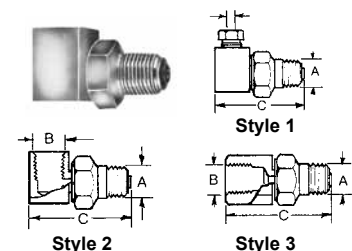

Swivels

Part No.	Style	A	B	C
66717	1	1/8" NPT	—	1 1/4" / 31.8mm
91048	2	1/8" NPT	1/8" NPT	1 1/4" / 31.8mm
91308	3	1/8" NPT	1/8" NPT	1 3/8" / 34.9mm

Note: Not suitable for installations requiring continuous rotation.

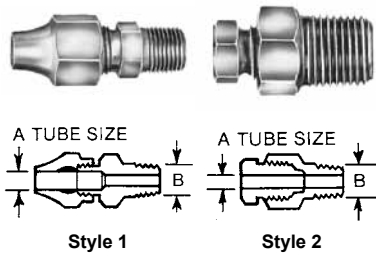

Tube Connectors

Part No.	Style	A	B	Type
66200	1	¼" O.D.	⅛" NPT	STGT
66201	1	¼" O.D.	⅛" NPT	90°
66414	2	⅛" O.D.	⅛" NPT	90°
66415	2	⅛" O.D.	⅛" NPT	STGT
66714	2	⅛" O.D.	¼"-28 thd.	STGT
66716	2	⅛" O.D.	¼"-28 thd.	90°



Compression Nut

No. 66260 for use with Style 2 Tube Connectors and 66717 Swivel.
For ⅛" O.D. Tubing. Thread size is ⅝"-24.



Sleeve

No. 68462 for use with Style 1 Tube Connectors. For ¼" O.D. Tubing.



Nut

No. 68464 for use with Style 1 Tube Connectors. For ¼" O.D. Tubing.

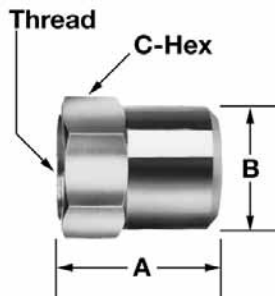

Zerk-Lock® Grease Fitting Adapter

Connects any ⅛" NPTF male tube adapter directly to a standard grease fitting. Aluminum, carbon steel construction; fluorocarbons elastomer seal. Useful for connecting to drive-type fittings or metric fittings. Once installed, the Zerk-Lock cannot be removed from the fitting.

Part No.	Threads in. / mm	A in./mm	B in./mm	C in./mm
270784	⅛" NPSL Female	.625 / 15.9	.500 / 12.7	.500 / 12.7

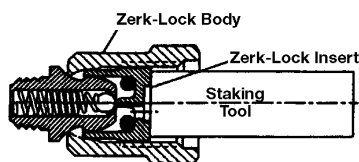

Installation Accessories



No. 247615 Staking Tool



Quicklinec® Fittings

Use for connections to 1/4" nylon tubing only. Can be used with Zerk-Lock® adapter or be screwed directly into bearing.

Part No.	Description
243699	1/4" tube x 1/8" NPT male 90° swivel fitting
244047	1/4" tube x 1/8" NPT male straight fitting
244048	1/4" tube x 1/8" NPT male 90° fitting
244053	1/4" tube x 1/4" -28 male 90° swivel fitting
244054	1/4" tube x 1/4" -28 male 90° fitting
244055	1/4" tube x 1/4" -28 male straight fitting
244058	1/4" tube x 1/4" tube splicer union



Divider Valve Outlet & Inlet Adapters for use with 272401 and 272394 Hose Stud

Part No.	Description
272658	Valve outlet fitting with check - 10mm
272659	1/8" NPT male straight fitting

IMPORTANT: Use the valve adapters for connecting the 1/8" high pressure hose (incl. hose stud with groove) to the main divider valve. The collet of the adapter is not knurled and has a wide collar.

Part No.	Description
432-24313-1	Protective Quicklinec rubber boot



Standard Compression Fittings

Part No.	Description
241290	1/4" tube x 1/8" NPT male straight fitting
241293	1/4" tube x 1/8" NPT male 90° fitting

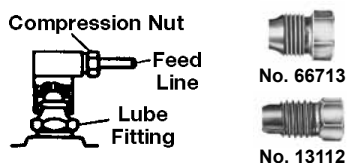

Snap-On Connector Fittings

Part No.	Description
241388	90° snap-on connector for 1/4" O.D. tubing
241389	Straight snap-on connector for 1/4" O.D. tubing
66713	Compression nut for 241388 and 241389
82617	Straight snap-on connector for 1/8" O.D. tubing
82618	90° snap-on connector for 1/8" O.D. tubing
13112	Compression nut

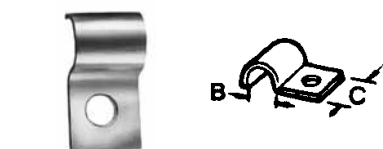

Tube Clamps for 1/4" O.D. Tubing

Part No.	A	B	C	No. of Tubes
64533-1	—	1/4" / 6.4	1/2" / 12.7	1
64533-2	15/16" / 23.8 mm	1/2" / 12.7	3/8" / 9.5	2
64533-3	13/16" / 30.2 mm	3/4" / 19.1	3/8" / 9.5	3
64533-4	17/16" / 36.5 mm	1" / 25.4	3/8" / 9.5	4
64533-5	111/16" / 42.9 mm	1 1/4" / 31.8	3/8" / 9.5	5

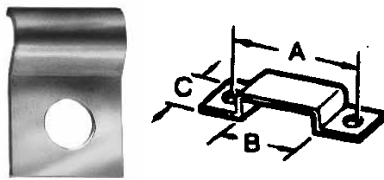

Tube Clamps for 1/8" O.D. Tubing

Part No.	A	B	C	No. of Tubes
64532-1	—	1/8" / 3.2	1/2" / 12.7	1
64532-2	1 1/16" / 17.5 mm	1/4" / 6.4	3/8" / 9.5	2
64532-3	1 3/16" / 20.6 mm	3/8" / 9.5	3/8" / 9.5	3
64532-4	1 5/16" / 23.8 mm	1/2" / 12.7	3/8" / 9.5	4
64532-5	1 1/16" / 27.0 mm	5/8" / 15.9	3/8" / 9.5	5

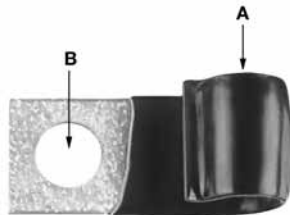

Insulated "J" Type Clamps

Part No.	A	B
68511	7/16" / 11.1 mm opening	1 3/32" / 10.3 dia. hole
68535	7/16" / 11.1 mm opening	1 7/32" / 13.5 dia. hole
68987	1 1/16" / 17.5 mm opening	7/16" / 11.1 dia. hole

Clip Screw



#6 Thd - 1/4" Long

No. 66202 for use in mounting 64532 and 64533 series tube clamps.



Spiral Wrap

Bulk Supply and Feed Line Hose and Tubing

Part No.	Description
241110	Feed line bundling spiral wrap (10 ft. / 3 m length)
241120	Feed line bundling spiral wrap (20 feet/6m of spiral wrap)
241054	Nylon ties (100 count poly bag) 7" / 177.8 m length
241055	Nylon ties (50 count poly bag) 7" / 177.8 m length
241056	Nylon ties (25 count poly bag) 7" / 177.8 m length
242125	Plastic grease fitting cap
274097	20 feet/6m of 3/8" convoluted loom/split wrap
274098	20 feet/6m of 1/2" convoluted loom/split wrap
274099	20 feet/6m of 5/8" convoluted loom/split wrap



Nylon Ties



Plastic Cap
242125



Convoluted Loom/Split Wrap

Lubrication Fittings & Accessories

Carton Quantities



Our popular fitting models are packaged in a convenient 100 piece carton for your small order requirements. Order a quantity of one and receive 100 pieces of that fitting.

1/8" NPT

100 Pc. Box No.	Bulk No.	Description	Length
5000C	5000	Straight	2 ¹ / ₃₂ "
5003C	5003	Straight	1 ¹ / ₄ "
5200C	5200	45° angle	7 ⁷ / ₈ "
5300C	5300	65° angle	2 ⁹ / ₃₂ "
5400C	5400	90° angle	2 ⁷ / ₃₂ "



1/4" NPT

100 Pc. Box No.	Bulk No.	Description	Length
5350C	5350	65° angle 1/4" NPT	1 ⁵ / ₃₂ "
5050C	5050	Str. 1/4" NPT	1 ⁵ / ₁₆ "

1/4"-28 SAE

100 Pc. Box No.	Bulk No.	Description	Length
5010C	5010	Straight-short thread	1/2"
5013C	5013	Straight-long thread	1 ¹ / ₁₆ "
5527C	5527	Straight-short thread	3 ¹ / ₆₄ "
5210C	5210	45° angle-short thread	7 ⁷ / ₈ "
5410C	5410	90° angle-short thread	2 ⁵ / ₃₂ "

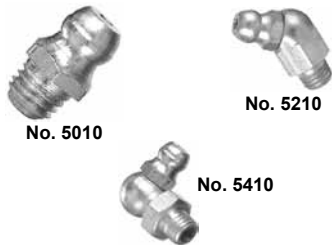

Metric

100 Pc. Box No.	Bulk No.	Description	Length
5175C	5175	Straight	6mm
5176C	5176	45°	6mm
5177C	5177	90°	6mm
5178C	5178	Straight	8mm
5179C	5179	45°	8mm
5180C	5180	90°	8mm
5181C	5181	Straight	10mm
5182C	5182	45°	10mm
5183C	5183	90°	10mm

Button Head

100 Pc. Box No.	Bulk No.	Description	Length
5701C	5701	1/8" NPT(m) thread	2 ⁵ / ₃₂ "
5706C	5706	1/4" NPT(m) thread	5 ³ / ₆₄ "



Drive-Type

100 Pc. Box No.	Bulk No.	Description	Length	Drive Dia.
5033C	5033	Straight	9 ⁹ / ₁₆ "	3 ³ / ₁₆ "
5385C	5385	65° angle	1 ³ / ₁₆ "	3 ³ / ₁₆ "
5031C	5031	Straight	3 ⁷ / ₆₄ "	5 ¹ / ₁₆ "



Lubrication Fittings & Accessories

Carton Quantities



Our standard bulk fittings are boxed in easy to handle cartons weighing approximately 30 pounds. The cartons are approximately 9"x9"x5". Order your fittings in these standard carton quantity increments to reduce your handling time.

Part No.	Standard Box Quantity	Part No.	Standard Box Quantity
5000	2500	5410-9	1500
5000-1	2500	5505	1000
5000-9	2500	5527	6000
5003	1200	5677	2700
5009	500	5678	2700
5010	5000	5679	2700
5010-9	5000	5680	2700
5013	4500	5698	1300
5014	3000	5701	1000
5031	3500	5706	800
5033	5500	5711	400
5033-9	5500	13154	1000
5036	2700	13155	750
5045	1500	20024	1300
5050	1000	20026	1300
5099	2500	20028	1000
5200	1500	20029	900
5210	2000	20031	1000
5300	1300	205000	2500
5308	1000	205010	5000
5318	2000	205200	1500
5350	700	205210	2000
5385	2200	205400	1300
5400	1300	205410	1500
5410	1500	240646	5000

Steel Tubing

For supply and feedlines.

Part No.	Size (O.D. x Wall)			Working Pressure	Type
	O.D. in.	Wall in.	Length ft. / m		
62175	1/8	.020	25 / 7.6	4400 psig / 300 bar	Coil
62176	1/4	.028	25 / 7.6	2800 psig / 190 bar	coil
62249	3/8	.028	25 / 7.6	1850 psig / 126 bar	coil

Type 304 Stainless Steel Tubing

For supply and feedlines. For corrosive environments. ASTM A-269 specs.

Part No.	Size (O.D. x Wall)			Working Pressure	Type
	O.D. in.	Wall in.	Length ft. / m		
62948-9	1/8	.028	20/ 6.1	9000 psig / 612 bar	coil
62949-9	1/4	.028	20/ 6.1	4480 psig / 305 bar	coil
62950-9	3/8	.028	20/ 6.1	2980 psig / 203 bar	coil

Nylon Tubing

For feedlines. Temperature range -65°F to 150°F.

Part No.	Size (O.D. x Wall)			Working Pressure	Minimum Bend Radius in.
	O.D. in.	Wall in.	Length ft. / m		
62256	1/8	.026	25 / 7.6	625 psig / 42.5 bar	.375
62278			100 / 30.5		
62956			500 / 152		
62357	1/4	.050	100 / 30.5		.875
247022			500 / 152		

Single and Multiple Tube Clamps

For feedlines.

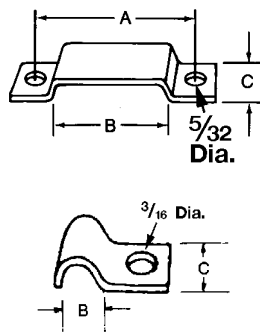

Clamp No.	Const.	No. Tubes	Tube Size in.	A in.	B in.	C in.	Screw No.	Screw Descrip.
64532-1	Steel	1	1/8 OD	—	1/8	1/2	66202	No. 6 roundhead 1/4" LG, Use No. 30 drill
64532-2		2		1 1/16	1/4	3/8		
64532-3		3		1 3/16	3/8	3/8		
64532-4		4		1 5/16	1/2	3/8		
64532-5		5		1 1/8	5/8	3/8		
64533-1		1/4 OD	1	—	1/4	1/2		
64533-2			2	1 5/16	1/2	3/8		
64533-3			3	1 3/16	3/4	3/8		
64533-4			4	1 7/16	1	3/8		
64533-5			5	1 1 1/16	1 1/4	3/8		
69159-9	Type 303 Stainless Steel	1	1/8 OD	—	1/8	3/8	66202-9	
69160-9		2		1 1/16	1/4	3/8		
69161-9		3		1 3/16	3/8	3/8		
69163-9		5		1 1/16	5/8	3/8		

Single Tube Clamps

For supply lines.

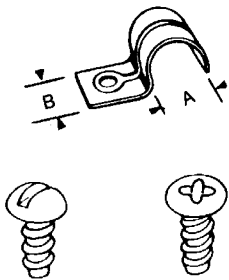

Clamp No.	Const.	Tube Size in.	A in.	B in.	Screw No.	Screw Description
360108	Steel	3/8 OD	3/8	1/2	66872	No. 10 round head, self-tapping 1/4" LG, use No. 17 drill
69164-9	Type 303	1/4 OD	1/4	3/8	66202-9	No. 6 round head, self-tapping 1/4" LG, use No. 30 drill
69165-9	Stainless Steel	3/8 OD	3/8	1/2	66872-9	No. 10 round head, self-tapping 1/4" LG, use No. 17 drill

Note: Screws listed in above tables. Order separately.

P Clamps

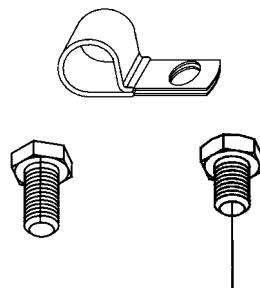

Clamp No.	Description	Material	Width in.	Length in.	Screw Description
249853	1 3/16" P style clamp	CRS	1	2 7/32	Use 249848 or 249849 bolts
249913	3/8" P style clamp	CRS	1		
270931	3/4" P style clamp	CRS	1	2 3/16	

Spring Coil

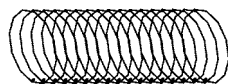

Clamp No.	Description	Material	Width in.	Screw Description
272598	25' spring coil	Steel	5/8 ID	Use 249848 or 249849 bolts

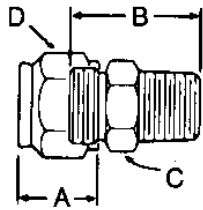

Heavy-Duty Tube Fittings—Male Connector

Tube to male pipe thread. For supply lines. Carbon steel unless noted (*) otherwise.

Part No.	Tube O.D. in.	Pipe Thread in.	A in.	B in.	Hex. C in.	Hex. D in.	Working Press. psig / bar
69068	1/4	1/8 NPT	19/32	61/64	1/2	5/8	5000 / 340
* 69068-9	3/8	1/8 NPT	19/32	61/64	1/2	5/8	5000 / 340
69069	1/4	1/4 NPT	19/32	15/32	5/8	5/8	5000 / 340
* 69069-9	1/4	1/4 NPT	19/32	15/32	5/8	5/8	5000 / 340
69070	3/8	1/8 NPT	3/4	1	5/8	3/4	5000 / 340
69071	3/8	1/4 NPT	3/4	1 13/64	5/8	3/4	5000 / 340
69072	3/8	3/8 NPT	3/4	1 13/64	3/4	3/4	5000 / 340

* 316 Stainless Steel

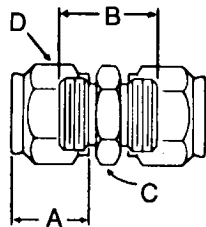

Heavy-Duty Tube Fittings—Union Connector

Tube to tube. For supply lines. Carbon steel unless noted (*) otherwise.

Part No.	Tube O.D. in.	A in.	B in.	Hex. C in.	Hex. D in.	Working Press. psig / bar
69078	3/8	3/4	1 1/16	5/8	3/4	6000 / 400

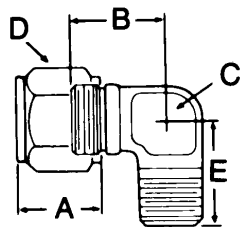

Heavy-Duty Tube Fittings—Male Elbow

Tube to male pipe thread. For supply lines. Carbon steel unless noted (*) otherwise.

Part No.	Tube O.D. in.	Pipe Thd. in.	A in.	B in.	Flats C in.	Hex. D in.	E in.	Working Press. psig / bar
* 69079-9	1/4	1/8 NPT	19/32	3/4	7/16	5/8	25/32	5000 / 340
69082	3/8	1/4 NPT	3/4	59/64	9/16	3/4	1 3/32	5000 / 340
* 69082-9	3/8	1/4 NPT	3/4	59/64	9/16	3/4	1 3/32	5000 / 340

* 316 Stainless Steel

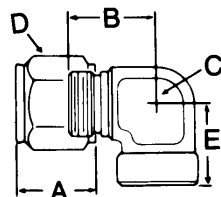

Heavy-Duty Tube Fittings—Female Elbow

Tube to female pipe thread. For supply lines. Carbon steel unless noted (*) otherwise.

Part No.	Tube O.D. in.	Pipe Thd. in.	A in.	B in.	Flats C in.	Hex. D in.	E in.	Working Press. psig / bar
69084	1/4	1/8 NPT	19/32	25/32	1/2	5/8	1 1/16	5000 / 340
* 69085	1/4	1/4 NPT	19/32	1	3/4	5/8	7/8	5000 / 340

* 316 Stainless Steel

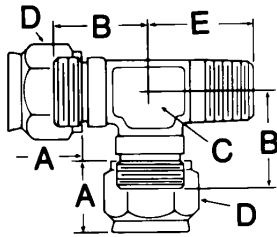

Heavy-Duty Tube Fittings—Male Run Tee

Tube to male pipe thread to tube. For supply lines. Carbon steel unless noted (*) otherwise.

Part No.	Tube O.D. in.	Pipe Thd. in.	A in.	B in.	Flats C in.	Hex. D in.	E in.	Working Press. psig / bar
69089	1/4	1/4 NPT	19/32	25/32	1/2	5/8	19/16	5000 / 340

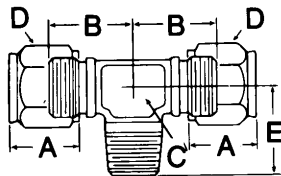

Heavy-Duty Tube Fittings—Male Branch Tee

Tube to tube to male pipe thread. For supply lines. Carbon steel unless noted (*) otherwise.

Part No.	Tube O.D. in.	Pipe Thd. in.	A in.	B in.	Flats C in.	Hex. D in.	E in.	Working Press. psig / bar
69093	3/8	1/4 NPT	3/4	63/64	5/8	3/4	1 1/16	5000 / 340

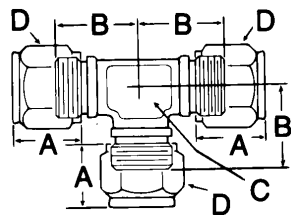

Heavy-Duty Tube Fittings—Union Tee

Tube to tube to tube. For supply lines. Carbon steel unless noted (*) otherwise.

Part No.	Tube O.D. in.	A in.	B in.	Flats C in.	Hex. D in.	Working Press. psig / bar
69094	1/4	19/32	3/4	7/16	5/8	5000 / 340
69095	3/8	3/4	63/64	5/8	3/4	5000 / 340

* 316 Stainless Steel

Heavy-Duty Tube Fittings—Sleeve

For supply lines. Carbon steel unless noted (*) otherwise.

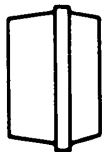

Part No.	Tube O.D. in.
69098	1/4
69099	3/8

* 316 Stainless Steel

Standard-Duty Tube Fittings—Male Connector

Tube to male pipe thread. For supply and feed lines. Brass unless noted (*) otherwise.

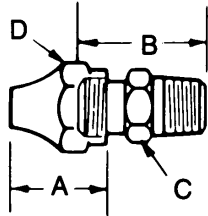

Part No.	Tube O.D. in.	Pipe Thd. in.	A in.	B in.	Hex. C in.	Hex. D in.	Working Press. psig / bar
66200	1/4	1/8 NPT	3/4	7/8	7/16	9/16	2000 / 136
66211	1/4	1/4 NPT	3/4	1 1/16	9/16	9/16	2000 / 136
68415	3/8	1/8 NPT	7/8	3 1/32	9/16	1 1/16	2000 / 136
66846	3/8	1/4 NPT	7/8	1 5/32	9/16	1 1/16	2000 / 136
* 69169-9	1/8	1/8 NPT	3 3/64	2 7/32	7/16	1/2	2000 / 136

* 316 Stainless Steel

Standard-Duty Tube Fittings—Female Connector

Tube to female pipe thread. For supply and feed lines. Brass unless noted (*) otherwise.

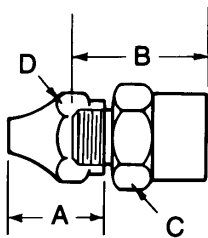

Part No.	Tube O.D. in.	Pipe Thd. in.	A in.	B in.	Hex. C in.	Hex. D in.	Working Press. psig / bar
68943	1/4	1/8 NPT	3/4	2 5/32	9/16	9/16	2000 / 136

Standard-Duty Tube Fittings—Male Elbow

Tube to male pipe thread. For supply and feed lines. Brass unless noted (*) otherwise.

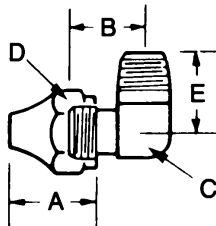

Part No.	Tube O.D. in.	Pipe Thd. in.	A in.	B in.	Flats C in.	Hex. D in.	E in.	Working Press. psig / bar
66201	1/4	1/8 NPT	3/4	1 9/32	7/16	9/16	2 3/32	2000 / 136
66210	1/4	1/4 NPT	3/4	5/8	9/16	9/16	3/4	2000 / 136
68412	3/8	1/8 NPT	7/8	1 1/16	9/16	1 1/16	1 1/16	2000 / 136
66762	3/8	1/4 NPT	7/8	2 3/32	9/16	1 1/16	2 9/32	2000 / 136
68414	3/8	3/8 NPT	7/8	2 7/32	1 1/16	1 1/16	3 1/32	2000 / 136
* 69166-9	1/8	1/8 NPT	3 3/64	2 1/32	7/16	1/2	3/4	2000 / 136

* 316 Stainless Steel

Standard-Duty Tube Fittings—Male Run Tee

For supply and feed lines. Brass unless noted (*) otherwise. Tube to male pipe thread to tube.

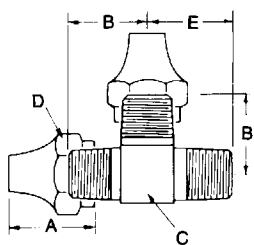

Part No.	Tube O.D. in.	Pipe Thd. in.	A in.	B in.	Flats C in.	Hex. D in.	E in.	Working Press. psig / bar
68615	1/4	1/8 NPTF	3/4	2 1/32	7/16	9/16	2 3/32	2000 / 136

Standard-Duty Tube Fittings—Male Branch Tee

Tube to tube to male pipe thread. For supply and feed lines. Brass unless noted (*) otherwise.

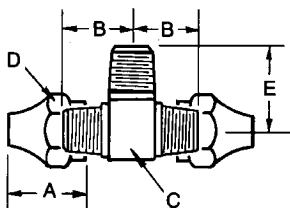

Part No.	Tube O.D. in.	Pipe Thd. in.	A in.	B in.	Flats C in.	Hex. D in.	E in.	Working Press. psig / bar
66651	1/4	1/8 NPTF	3/4	2 1/32	7/16	9/16	2 3/32	2000 / 136
66876	3/8	1/4 NPTF	7/8	2 5/32	9/16	1 1/16	2 9/32	2000 / 136

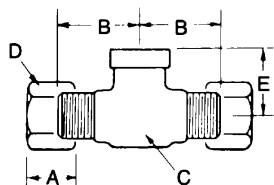

Standard-Duty Tube Fittings—Female Branch Tee

Tube to tube to female pipe thread. For supply and feed lines. Brass unless noted (*) otherwise.

Part No.	Tube O.D. in.	Pipe Thd. in.	A in.	B in.	Flats C in.	Hex. D in.	E in.	Working Press. psig / bar
67374	3/8	1/4 NPTF	3/4	1 1/16	3/4	1 1/16	7/8	2000 / 136

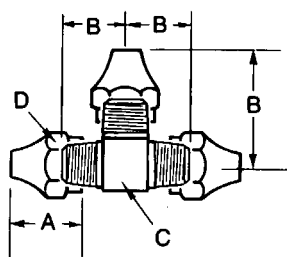

Standard-Duty Tube Fittings—Union Tee

Tube to tube to tube. For supply and feed lines. Brass unless noted (*) otherwise.

Part No.	Tube O.D. in.	A in.	B in.	C in.	Hex. D in.	Working Press. psig / bar
66650	1/4	3/4	5/8	7/16	9/16	2000 / 136
66878	3/8	7/8	23/32	9/16	1 1/16	2000 / 136

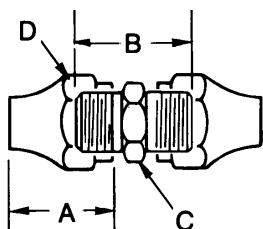

Standard-Duty Tube Fittings—Union

Tube to tube. For supply and feed lines. Brass unless noted (*) otherwise.

Part No.	Tube O.D. in.	A in.	B in.	Hex. C in.	Hex. D in.	Working Press. psig / bar
68468	1/4	3/4	25/32	7/16	9/16	2000 / 136

Standard-Duty Tube Fittings—Sleeve

For supply and feed lines. Carbon steel unless noted (*) otherwise. Included with all standard duty fittings.

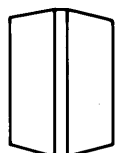

Part No.	Tube O.D. - in.
68462	1/4
68463	3/8
* 69170-9	1/8

* 316 Stainless Steel

Standard-Duty Tube Fittings—Nut

For supply and feed lines. Carbon steel unless noted (*) otherwise. Included with all standard duty fittings.



Part No.	Tube O.D. in.	A in.	Hex. D in.
68464	1/4	3/4	9/16
* 69171-9	1/8	33/64	1/2

* 316 Stainless Steel

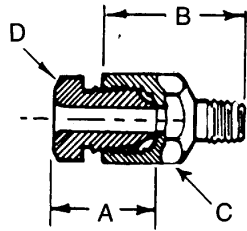

Threaded Sleeve Tube Fittings—Straight

Tube to male thread. For feed lines. Carbon steel with brass nut unless noted (*) otherwise.

Part No.	Tube O.D. in.	Thread in.	A in.	B in.	Hex. C in.	Hex. D in.	Working Press. psig / bar
66771	1/8	10-32	1/2	11/16	3/8	5/16	500 / 34
66714	1/8	1/4-28	1/2	5/8	3/8	5/16	500 / 34
* 66714-9	1/8	1/4-28	1/2	5/8	3/8	5/16	500 / 34
66772	1/8	1/4-28	1/2	11/16	3/8	5/16	500 / 34
66730	1/8	5/16-32	1/2	11/16	3/8	5/16	500 / 34
66773	1/8	3/8-24	1/2	11/16	7/16	5/16	500 / 34
66415	1/8	1/8 NPTF	1/2	5/8	7/16	5/16	500 / 34

* 303 Stainless Steel

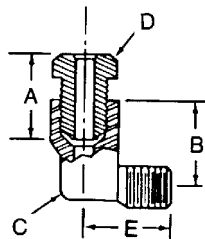

Threaded Sleeve Tube Fittings—90° Elbow

Tube to male thread. For feed lines. Brass with brass nut unless noted (*) otherwise.

Part No.	Tube O.D. in.	Thread in.	A in.	B in.	Flats C in.	Hex. D in.	E in.	Working Press. psig / bar
66716	1/8	1/4-28	1/2	1/2	13/32	5/16	33/64	500 / 34
66414	1/8	1/8 NPTF	1/2	1/2	7/16	5/16	21/32	500 / 34

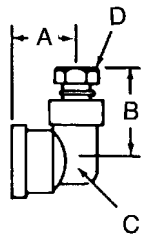

Threaded Sleeve Tube Fittings—90° Elbow

Tube to female pipe thread. For feed lines. Brass with brass nut unless noted (*) otherwise.

Part No.	Tube O.D. in.	Pipe Thd. in.	A in.	B in.	Flats C in.	Hex. D in.	Working Press. psig / bar
66935	1/8	1/8 NPT	23/32	11/32	3/8	5/16	500 / 34

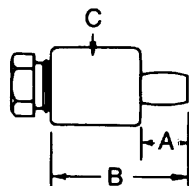

Threaded Sleeve Tube Fittings—Drive-Type

For feed lines. Steel body with brass nut.

Part No.	Hole Size in.	Tube O.D. in.	A in.	B in.	Dia. C in.	Hex. D in.	Working Press. psig / bar
82092	3/16	1/8	13/64	45/64	7/16	5/16	500 / 34

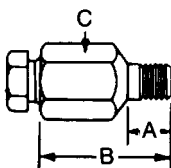

Threaded Sleeve Tube Fittings—Spin-Drive Type

For feed lines. Steel body with brass nut.

Part No.	Hole Size in.	Tube O.D. in.	A in.	B in.	Hex. C in.	Hex. D in.	Working Press. psig / bar
82093	1/4	1/8	5/32	5/8	7/16	5/16	500 / 34

Threaded Sleeve Tube Fittings—Compression Nuts

For feed lines. Brass unless noted (*) otherwise.

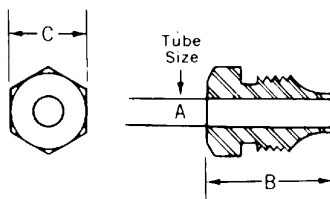

Part No.	A Tube Size O.D. in.	B in.	C in.	Working Press. psig / bar
66260	1/8	1/2	5/16	500 / 34
* 66260-9	1/8	1/2	5/16	500 / 34
66713	1/4	5/8	7/16	500 / 34

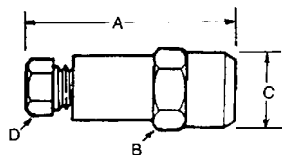

Snap-on Coupler Tube Fittings—Straight

Connect tubing to existing hydraulic (grease) fittings. Aluminum body, brass nut, Buna N packing.

Part No.	Tube O.D. Size in.	A in.	B Hex in.	C in.	D Hex in.	Working Press. psig / bar
* 82617	1/8	1.18	7/16	.43	1/4	500 psi / 34 bar
** 241389	1/4	1.69	5/8	.43	7/16	

* Uses Model 13112 compression nut (included). **Uses 66713 compression nut (included).

Note: Coupling to grease fitting is a permanent connection.

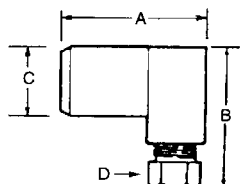

Snap-on Coupler Tube Fittings—90° Elbow

Connect tubing to existing hydraulic (grease) fittings. Aluminum body, brass nut, Buna N packing.

Part No.	Tube O.D. Size in.	A in.	B Hex in.	C in.	D Hex in.	Working Press. psig / bar
* 82618	1/8	.83	.86	.43	1/4	500 psi / 34 bar
** 241388	1/4	1.03	1.18	.43	7/16	

* Uses Model 13112 compression nut (included). **Uses 66713 compression nut (included).

Note: Coupling to grease fitting is a permanent connection.

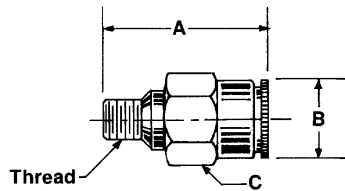

Quicklinc™ Tubing Adapter—Male Straight

Use with ¼" O.D. non-metallic tube for quick installation. Tubing simply pushes into place without ferrules or flairs. Nickel plated brass construction.

Part No.	Tube O.D. Size - in.	Thread	Dimensions - in. / mm			Max. Oper. Pressure
			A	B	C-Hex	
244047	¼	⅛" NPTF	.984 / 25	.460 / 11.7	.472 / 12	250 psig 17 bar
244055		¼" -28	.784 / 19.9			
244057		M6 X 1-6G Tapered	.965 / 24.5			

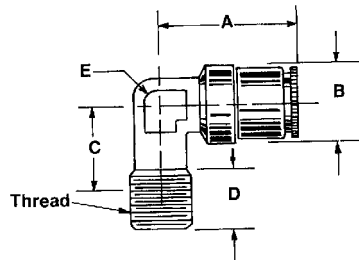

Quicklinc™ Tubing Adapter—Male 90° Elbow, Non-Swivel

Use with ¼" O.D. non-metallic tube for quick installation. Tubing simply pushes into place without ferrules or flairs. Nickel plated brass construction.

Part No.	Tube O.D. Size - in.	Thread	Dimensions - in. / mm					Max. Oper. Pressure
			A	B	C	D	E-Flat	
244048	¼	⅛" NPTF	.905 / 23	.500 / 12.7	.531 / 13.5	.374 / 9.5	.394 / 10	250 psig 17 bar
244054		¼" -28				.172 / 4.4		
244056		M6 X 1-6G Tapered				.590 / 15		

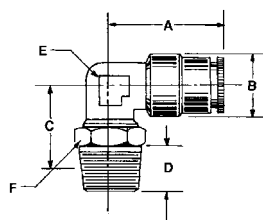

Quicklinc™ Tubing Adapter—Male 90° Elbow, Swivel

Use with ¼" O.D. non-metallic tube for quick installation. Tubing simply pushes into place without ferrules or flairs. Nickel plated brass construction.

Part No.	Tube O.D. Size in.	Thread	Dimensions - in. / mm						Max. Oper. Pressure
			A	B	C	D	E-Flat	F-Hex	
243699	¼	⅛" NPTF	.905 / 23	.500 / 12.7	.728 / 18.5	.374 / 9.5	.354 / 9	.472 / 12	250 psig 17 bar
244053		¼" - 28							

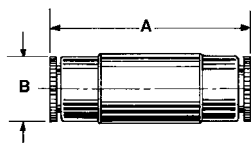

Quicklinc™ Tubing Adapter—Tube Union

Use with ¼" O.D. non-metallic tube for quick installation. Tubing simply pushes into place without ferrules or flairs. Nickel plated brass construction.

Part No.	Tube O.D. Size in.	Dimensions - in. / mm		Max. Oper. Pressure
		A	B	
244058	¼	1.397 / 35.5	.460 / 11.7	250 psig 17 bar

Supply Line and Material Hose

Type	I.D. in.	Wire Braid	Working Pressure	Min. Burst Pressure	Fittings in.	Min. Bend Radius in.	Part No.	Length	
								in.	cm
75 High Pressure	1/4	Double	5000 psig / 340 bar	20000 psig / 1360 bar	1/2 -27 female	4	75024	24	
							75060	60	
							75084	84	
							75120	120	
							75168	168	
							75240	240	
							75360	360	
							75480	480	
759 High Pressure	3/16		4500 psig / 306 bar		1/8 NPT male	2 1/2	75948	48	122
							75960	60	152
76B High Pressure	3/8		4000 psig / 272 bar	16000 psig / 1088 bar	1/2 NPT female	5	76024B	24	61
							76600B	600	1525
76A High Pressure	1/2		3500 psig / 238 bar	14000 psig / 952 bar		7	76900B	900	2288
							76024A	24	61
76A High Pressure							76600A	600	1525
79 Volume Med. Pressure	3/8		2250 psig / 153 bar	9000 psig / 612 bar	3/8 NPT male	5	79060	60	152.4
73 Med. Pressure	1/2	Single	1000 psig / 68 bar	4000 psig / 68 bar	1/2 NPT male		73024	24	61
							73036	36	91.4
							73060	60	152.4
							73120	120	305
							73240	240	610
							73360	360	915
							73480	480	1220
							73600	600	1525
73900	900	2288							
78 Med. Pressure	5/8		1500 psig / 102 bar	6000 psig / 408 bar			78600	600	1525
1230 Med. Pressure	3/4	Double	2250 psig / 153 bar	9000 psig / 612 bar	3/4 NPT male		1230120	120	305

Note: Refer to Design Guides for the correct hose for your system.

Feed Line Hose (SAE 30R-3 Type)

For flexible connections between lube outlets, anchor blocks, swivels, tube connectors and bearings. Hose is $\frac{3}{16}$ " I.D. x $\frac{3}{8}$ " O.D.

Series 71900

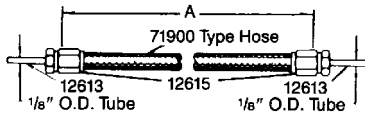

Part No.	Connections in.	Working Pressure	Min. Bend Radius in.	Length "A"	
				in.	cm
71908	$\frac{1}{8}$ O.D. tube x $\frac{1}{8}$ O.D. tube	500 psig / 34 bar	2	8	20.3
71912				12	30.5
71918				18	45.7

Series 82238

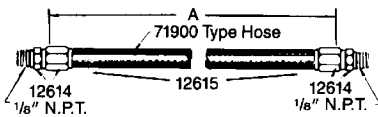

Part No.	Connections in.	Working Pressure	Min. Bend Radius in.	Length "A"	
				in.	cm
82238-12	$\frac{1}{8}$ NPTF(M) x $\frac{1}{8}$ NPTF(M)	500 psig / 34 bar	2	12	30.5
82238-18				18	45.7
82238-24				24	61

Series 81712

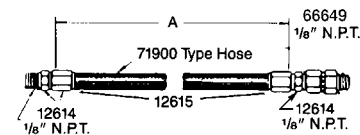

Part No.	Connections in.	Working Pressure	Min. Bend Radius in.	Length "A"	
				in.	cm
81712-6	$\frac{1}{8}$ NPTF(M) x #66649 Adapter Union $\frac{1}{8}$ NPTF(M)	500 psig 34 bar	2	6	15.2
81712-8				8	20.3
81712-18				18	45.7
81712-24				24	61
81712-30				30	76.2
81712-36				36	91.4

Series 82239

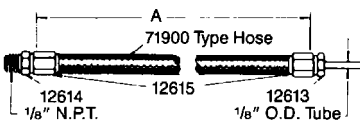

Part No.	Connections in.	Working Pressure	Min. Bend Radius in.	Length "A"	
				in.	cm
82239-12	$\frac{1}{8}$ O.D. tube x $\frac{1}{8}$ NPTF(M)	500 psig / 34 bar	2	12	30.5
82239-18				18	45.7
82239-24				24	61

Bulk Feed Line Hose and Fittings

Cut to required length and install connector fittings with standard wrenches. SAE 30R3 type hose. Temperature range -40°F to 212°F.

Bulk Type 71900 Hose

Part No.	Size		Working Pressure	Min. Bend Radius in.	Length ft. / m
	I.D. - in.	O.D. - in.			
66844	3/16	3/8	500 psig / 34 bar	2	25 / 7.6
71900					Specify length

Fittings for 71900 Hose

Part No.	Construction	Description	Size - in.
12613	Steel	Hose Stud	1/8 O.D. tube x 1/4 -28male
12614			1/8 NPTmale x 1/4 -28male
13003			1/4 -28male x 1/4 -28male
12720			1/8 O.D. tube x 1/4 -28male, 90° angle
* 12615		Coupling Nut	1/4 -28 female
12613-9	Type 303 Stainless Steel	Hose Stud	1/8 O.D. tube x 1/4 -28male
12614-9			1/8 NPTmale x 1/4 -28male
* 12615-9			Coupling Nut

* One coupling nut required for each hose stud.

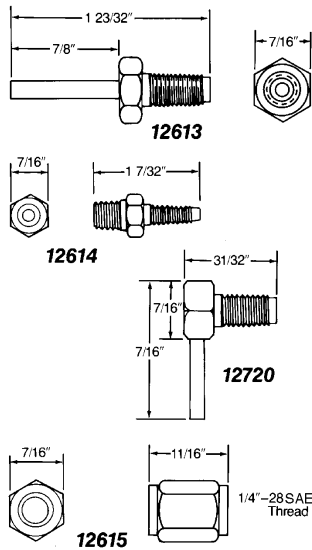

Air Hose

Connect system to compressed air supply.

Part No.	Length ft.	Specifications			Maximum Pressure		Braid
		I.D. in.	O.D. in.	Thread in.	Working	Burst	
72024	2	1/4	5/8	1/4 NPT male	250 psig / 17 bar	1250 psig / 85 bar	2-Ply Rayon
72036	3						
72060	5						
72120	10						
72240	20						
72480	40						
72600	50	23/32	3/8 NPT male	1/2 NPT male	200 psig / 14 bar	800 psig / 55 bar	1-Ply Rayon
72024A	2						
72360A	30						
72480A	40						
72600A	50						
72720A	60	1/2	1/2 NPT male	1/2 NPT male	200 psig / 14 bar	800 psig / 55 bar	1-Ply Rayon
74024	2						
74060	5						
74480	40						
74600	50						



Heavy-Duty Air Line Quick Disconnects

Rugged, high flow industrial design steel couplers and nipples.

Part No.	Description	Size	Max. Air Pressure
For 3/8" I.D. Hose			
645006	Coupler	3/8" NPT F	300 psig / 20 bar
For 1/2" I.D. Hose			
655008	Coupler	1/2" NPT F	300 psig
655012	Coupler	3/4" NPT F	
653112	Nipple	3/4" NPT M	20 bar
For 3/4" I.D. Hose			
662012	Coupler	3/4" NPT F	300 psig
660112	Nipple	3/4" NPT M	20 bar

Pipe Fittings—Reducing Bushings

For supply and feed lines.

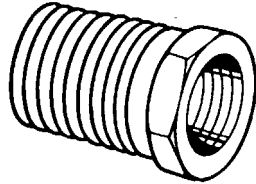

Part No.	Thread / in.	Construction
10461	1/8 NPTF female x 1/4 NPTF male	Steel
10200	1/8 NPTF female x 1/2-27 NPTF male	Brass
11229	1/4 NPTF female x 1/8 NPTF male	Steel
11348	1/4 NPTF female x 1/4 NPTF male	Steel
20011	1/4 NPTF female x 3/8 NPTF male	Steel
12080	1/4 NPTF female x 1/2 NPTF male	Steel
10204	1/4 NPTF female x 1/2-27 NPTF male	Brass
10049	3/8 NPTF female x 1/4 NPTF male	Steel
67069	3/8 NPTF female x 1/2 NPTF male	Steel
67198	3/8 NPTF female x 3/4 NPTF male	Steel
12989	1/2 NPTF female x 1/4 NPTF male	Steel
67171	1/2 NPTF female x 3/4 NPTF male	Steel
12287	1/2-27 NPTF female x 1/2 NPTF male	Steel

Pipe Fittings—Nipples

For supply and feed lines.

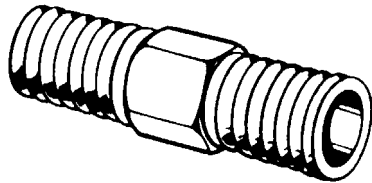

Part No.	Thread / in.	Style	Construction
10130	1/8 NPTF male x 1/8 NPTF male	Hex	Steel
67371	1/8 NPTF male x 1/8 NPTF male	Close	Brass
10772	1/8 NPTF male x 1/4 NPTF male	Hex	Steel
10199	1/8 NPTF male x 1/2-27 male	Hex	Brass
10462	1/4 NPTF male x 1/4 NPTF male	Hex	Steel
10462-9	1/4 NPTF male x 1/4 NPTF male	Hex	Stainless Steel-303
10198	1/4 NPTF male x 1/2-27 male	Hex	Brass
10773	3/8 NPTF male x 1/4 NPTF male	Hex	Steel
14727	3/4 NPTF male x 1/4 NPTF male	Hex	Steel
10540	3/8 NPTF male x 3/8 NPTF male	Hex	Steel
11107	3/8 NPTF male x 1/2 NPTF male	Hex	Steel
11197	1/2 NPTF male x 1/2 NPTF male	Hex	Steel
12957	1/2 NPTF male x 1/2-27 male	Hex	Steel
12106	1/2 NPTF male x 1/4 NPTF male	Hex	Steel
10202	1/2-27 male x 1/2-27 male	Hex	Brass

Pipe Fittings—Couplings

For supply and feed lines.

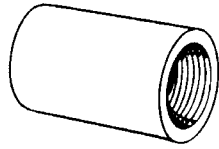

Part No.	Thread / in.	Construction
67063	1/8 NPTF female x 1/8 NPTF female	Steel
67360	1/8 NPTF female x 1/8 NPTF female	Brass
67179	1/2 NPTF female x 1/2 NPTF female	Forged Steel

Pipe Fittings—Reducing Couplings

For supply and feed lines.

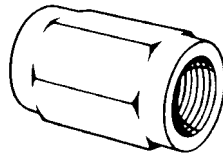

Part No.	Thread / in.	Construction
11852	1/8 NPTF female x 1/2-27 NPTF female	Steel
67094	1/4 NPTF female x 3/8 NPTF female	Malleable Iron
67176	1/4 NPTF female x 1/2 NPTF female	Forged Steel
10522	1/4 NPTF female x 1/2-27 female	Brass
67296	3/8 NPTF female x 1/2 NPTF female	Forged Steel

Pipe Fittings—Street Ells

For supply and feed lines.

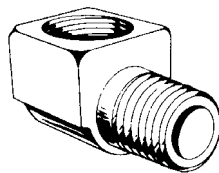

Part No.	Thread / in.	Construction
67368	1/8 NPTF female x 1/8 NPTF male	Brass
67368-9	1/8 NPTF female x 1/8 NPTF male	Stainless Steel-304
67054	1/4 NPTF female x 1/4 NPTF male	Brass
67358	3/8 NPTF female x 3/8 NPTF male	Brass
67074	1/2 NPTF female x 1/2 NPTF male	Malleable Iron
67062	3/4 NPTF female x 3/4 NPTF male	Malleable Iron

Pipe Fittings—Tees

For supply and feed lines.

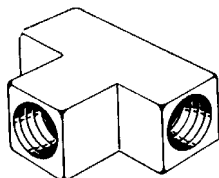

Part No.	Thread / in.	Construction
67011	1/8 NPTF female x 1/8 NPTF female	Brass
67102	1/4 NPTF female x 1/4 NPTF female	Brass
67102-9	1/4 NPTF female x 1/4 NPTF female	Stainless Steel-304
243373	1/2 NPTF female x 1/2 NPTF female	Forged Steel

Street Tee

Part No.	Description
67448	1/8" NPT male x 1/8" NPT female x 1/8" NPT female

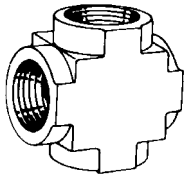

Pipe Fittings—Crosses

For supply and feed lines.

Part No.	Thread / in.	Construction
67362	1/8 NPTF	Brass

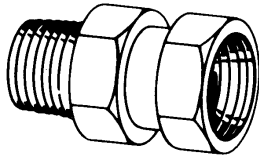

Pipe Fittings—Adapter Unions

For supply and feed lines.

Part No.	Thread / in.	Construction
66649	1/8 NPSM female swivel x 1/8 NPTF male	Steel
66645	1/4 NPSM female swivel x 1/4 NPTF male	Steel
66842	3/8 NPSM female swivel x 3/8 NPTF male	Steel
66883	1/2 NPSM female swivel x 1/2 NPTF male	Steel
69375	1 NPTF female swivel x 1 NPTF male	Steel

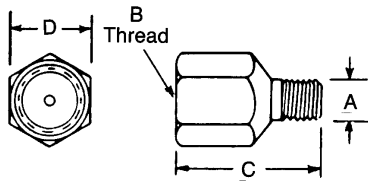

Pipe Fittings—Straight Adapters

For supply and feed lines. Carbon steel.

Part No.	A in.	B in.	C in.	D in.
20024	1/4-28	1/8 NPSF	7/8	1/2
66648	3/16-24	1/8 NPTF	31/32	9/16

Metric

Part No.	A in.	B in.	C in.	D in.
304-19166-1	M6 x 1	1/4-28	.56	.393/.472*
304-19165-1	M8 x 1			
304-19164-1	M10 x 1			

* Hex material may vary

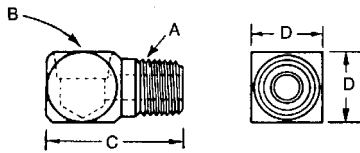

Pipe Fittings—90° Adapters

For supply and feed lines. Carbon Steel.

Part No.	A in.	B in.	C in.	D in.
20026	1/4-28	1/8 *	13/16	1/2
20029	1/8 *	1/8 **	1	1/2
20031	1/8 *	1/8 *	13/16	1/2
20012	1/4 *	1/4 NPTF	1 5/16	1 1/16

* PTF special extra short.

** SAE short.

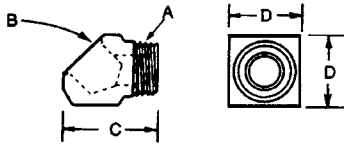

Pipe Fittings—45° Adapters

For supply and feed lines. Carbon Steel.

Part No.	A in.	B in.	C in.	D in.
20028	1/8 **	1/8 **	1	1/2
247616	1/4-28	1/8 *	1 1/16	1/2

* PTF special extra short.

** SAE short.

Supply Line Swivels—Straight Swivels (one swivel section)

For lubricant supply lines. Swivels have steel bodies and nitrile packing.

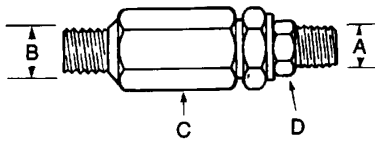

Part No.	A in.	B in.	C in.	D in.	Working Pressure
82080	1/2-27	1/2-27	7/8	9/16	5000 psig / 340 bar
83938	1/4 NPTF	1/4 NPTF	7/8	9/16	
81728	3/8 NPTF	1/2 NPTF	1 1/4	1 1/16	
82072	1/2 NPTF	1/2 NPTF	1 1/4	7/8	

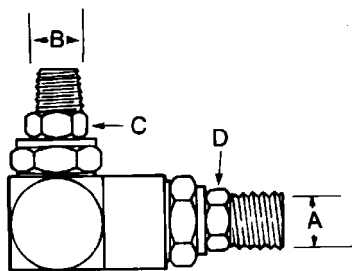

Supply Line Swivels—90° Angle Swivels (one swivel section)

For lubricant supply lines. Swivels have steel bodies and nitrile packing.

Part No.	A in.	B in.	C in.	D in.	Working Pressure
81386	1/8 NPTF	1/2-27	9/16	7/16	5000 psig 340 bar
81723	1/8 NPTF	1/8 NPTF	5/8	7/16	
81974	1/2-27	1/4 NPTF	9/16	9/16	
82251	1/8 NPTF	1/8 NPTF	7/16	7/16	
82087	1/2 NPTF	1/2 NPTF	7/8	7/8	

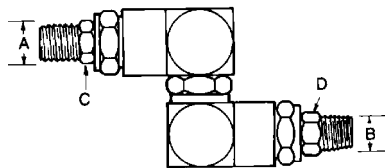

Supply Line Swivels—Universal Swivels (three swivel sections)

For lubricant supply lines. Swivels have steel bodies and nitrile packing.

Part No.	A in.	B in.	C in.	D in.	Working Pressure
82252	1/8 NPTF	1/8 NPTF	7/16	7/16	5000 psig 340 bar
83594	1/4 NPTF	1/4 NPTF	9/16	9/16	
81729	1/2 NPTF	3/8 NPTF	7/8	1 1/16	
82073	1/2 NPTF	1/2 NPTF	7/8	7/8	

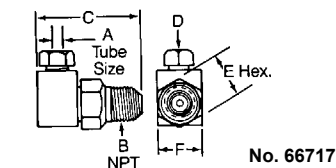

No. 66717

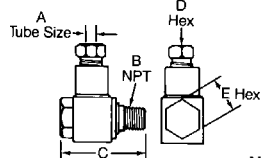

No. 83722

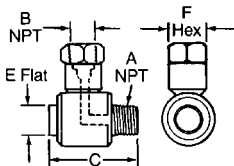

No. 83822

Feed Line Swivels—90° Angle Swivels

For lubricant feed lines. All models have a single swivel section and Buna N seals unless noted otherwise.

Part No.	A Inlet in.	B Outlet in.	C Length in.	D Hex in.	E Hex/Flat in.	F Flat in.
66717	1/8 O.D. Tube	1/8 NPTF (M)	1 1/4	5/16	9/16	1/2
* 66717-9				N/A		
91048	1/8 NPTF (F)	1/4 -28	1 5/16	1 5/16	3/8	
* 91048-9						
* 83722	1/8 O.D. Tube	1/4 -28	1 5/16	1 5/16	3/8	
83822	1/8 NPTF (M)	1/8 NPTF (F)	1 3/8	1/2		

* 303 Stainless Steel

Note: Models 91048 & 91048-9 are similar in appearance to 66717 & 66717-9, but do not include direct tube connections.

Feed Line Swivels—Straight Swivels

For lubricant feed lines. All models have a single swivel section and Buna N seals unless noted otherwise.

Part No.	A Thread in.	B Thread in.	C Length in.	D Hex in.	E Flat in.
91308	1/8 NPTF (F)	1/8 NPTF (M)	1 3/8	9/16	
* 92131			1 1/2	3/4	15/32
* 81606					

* With fluoroelastomer seals.

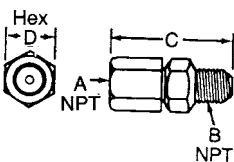

No. 91308

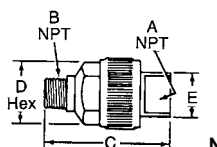

No. 81606

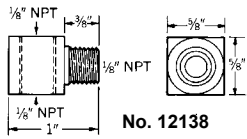

No. 12138

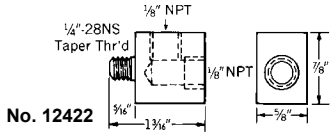

No. 12422

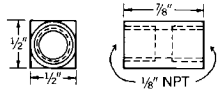

No. 12612

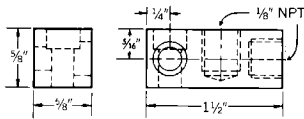

No. 81583

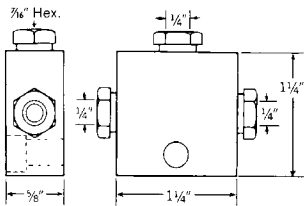

No. 82225

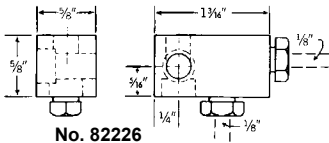

No. 82226

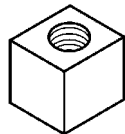

No. 270928



No. 249851



No. 249850

Anchor and Junction Blocks

Securely fasten flexible supply and feed lines.

Part No.	Description	Use with Series Injectors*	Installation Method
12138	Anchor Block	SL-1, 11, 32, 33, 41, 42, 43, 44	Use 1 1/2" drill and 1/8" NPT tap
12422		SL-1, 11, 32, 33, 41, 42, 43, 44	Use No. 3 drill and 1/4" -28 tap
** 81583		SL-1, 11, 32, 33, 41, 42, 43, 44	Use No. 7 drill and 1/4" -20 tap
** 82226		SL-32, 33, 42, 43	Use No. 7 drill and 1/4" -20 tap
** 82225	Junction Block	SL-32, 33, 42, 43	Use No. 7 drill and 1/4" -20 tap

* Can also be used with corresponding size supply and feed lines on Modular Lube II and Quicklub systems.

** Includes 50521 mounting screw.

Stand Offs for Mounting SSV Valves, P-Clamps and Angle Iron

Part No.	Description
252807	Valve mounting block for welding
249987	6 mm bolt to be used with the 252807
249850	12 mm round stand off
270928	12 mm square stand off
249848	12 mm x 5/8" long bolt to be used with 249850 and 270928
249851	10 mm round stand off
249849	10 mm x 5/8" long bolt to be used with 249851

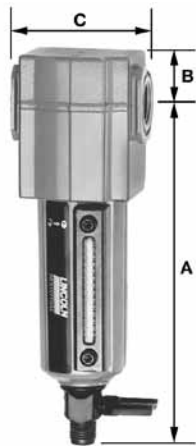

Modular Air Line Filters

Part No.	Maximum Air Supply	Material of Construction			Element
		Body	Bowl	Material	Particle Size
602104	250 psig / 17 bar	Zinc	Zinc*	Sintered Polypropylene	40μ
602106					
602108		Aluminum	Aluminum*		
602109					

Part No.	Drain Type	Port Size PTF	Dimensions - in. / mm				Weight lbs. / kg
			A	B	C	Dia.	
602104	Manual	1/4	5.27 / 1.34	0.75 / 19	1.98 / 50	1.91 / 48	1.1 / 0.5
602106		3/8					
602108		1/2	6.95 / 177	1.00 / 25	3.15 / 80	2.89 / 74	
602109	Automatic		6.35 / 161				



Modular Air Line Regulators

Part No.	Maximum Air Supply	Operating Temperature Range	Material of Construction				Secondary (Gauge) Connections in.
			Body	Bonnet	Valve Seals	Bottom Plug	
602004	300 psig / 20 bar	0° to 150°F / -18° to 65°C	Zinc	Acetal	Brass Nitrile	Acetal	1/8 NPT (F)
602005	300 psig / 20 bar	0° to 150°F / -18° to 65°C	Zinc	Acetal	Brass Nitrile	Acetal	1/8 NPT (F)
602006	300 psig / 20 bar	0° to 150°F / -18° to 65°C	Zinc	Acetal	Brass Nitrile	Acetal	1/8 NPT (F)
602007	300 psig / 20 bar	0° to 175°F / -18° to 79°C	Aluminum	Aluminum	Brass Nitrile	Acetal	1/4 NPT (F)
602008	300 psig / 20 bar	0° to 175°F / -18° to 79°C	Aluminum	Aluminum	Brass Nitrile	Acetal	1/4 NPT (F)

Part No.	Outlet Pressure Adj. Range	Connections NPT-Female in.	Dimensions - in. / mm				Adjuster	Weight lbs. / kg
			A	B	C	D		
602004	5 to 150 psig / 0.3 to 4 bar	1/4	4.0 / 102	1.31 / 33	2.0 / 50	3.2 / 83	T-Handle	0.8 / 0.4
602005			2.88 / 73				Knob	
602006		3/8	4.0 / 102				T-Handle	
602007			2.88 / 73				Knob	
602008	10 to 250 psig / 0.7 to 16 bar	1/2	5.95 / 151	1.69 / 43	3.15 / 80	5.1 / 130	T-Handle	1.77 / 0.80
602009	5 to 150 psig / 0.3 to 4 bar		5.0 / 127				Knob	

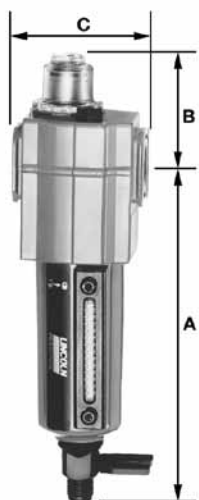

Modular Air Line Lubricators

Part No.	Maximum Air Supply	Operating Temperature Range	Material of Construction			Recommended Lubricants
			Body	Bowl	Sight feed Dome	
602204	250 psig / 17 bar	0° to 150°F / -18° to 65°C	Zinc	Zinc	Transp. Nylon	Misting type oil 50 to 200 SSU (ISO Grade 7 to 46) at 100°F (38°C)
602206			Aluminum	Aluminum*		
602208						

* Transparent nylon liquid level indicator lens.

Part No.	Connections NPT-Female in.	Bowl Capacity ozs. / ml	Dimensions - in. / mm				Weight lbs. / kg
			A	B	C	D	
602204	¼	2.0 / 58	5.27 / 134	1.63 / 41	1.98 / 50	1.91 / 48	1.1 / 0.5
602206	⅜						
602208	½	7.0 / 207	6.95 / 177	2.12 / 53	3.15 / 80	2.89 / 74	1.6 / 0.7



Integrated/Modular Filter/Regulator with Gauge

Can be used with other AirCare Modular Components.

Part No.	Maximum Air Supply	Element Particle Size	Outlet Pressure Adj. Range
602134	250 psig / 17 bar	40µ	5 to 150 psig / 0.3 to 10 bar
602136			
602138			

Part No.	Drain Type	Port Size PTF	Dimensions - in. / mm				Weight lbs. / kg
			A	B	C	D	
602134	Manual	¼	5.27 / 134	2.89 / 73	1.98 / 50	3.29 / 83	1.2 / 0.5
602136		⅜					
602138		½	6.95 / 177	4.98 / 127	3.15 / 80	5.10 / 130	

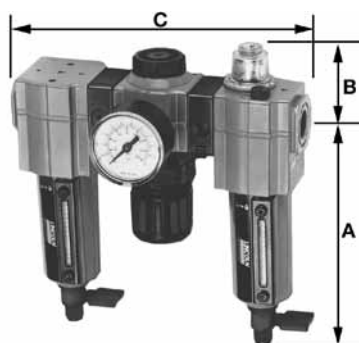

Modular Air Line Combination Units

Filter-Regulator with Gauge-Lubricator

Part No.	Maximum Air Supply	Operating Temperature Range:	Element Particle Size	Outlet Pressure Adj. Range	Lubricator Bowl Capacity ozs. / ml
85387-4	250 psig / 17 bar	0° to 150°F / -18° to 65°C	40µ	5 to 150 psig / 0.3 to 10 bar	2.0 / 58
85387-6					7.0 / 207
85387-8		0° to 175°F / -18° to 79°C			

* Transparent nylon liquid level indicator lens.

Part No.	Drain Type	Port Size PTF	Dimensions - in. / mm			Weight lbs / kgs
			A	B	C	
85837-4	Manual	¼	5.27 / 134	1.63 / 41	6.46 / 164	3.3 / 1.5
85837-6	Manual	⅜	5.27 / 134	1.63 / 41	6.46 / 164	3.3 / 1.5
85837-8	Manual	½	6.95 / 177	2.12 / 53	10.52 / 267	6.2 / 2.8

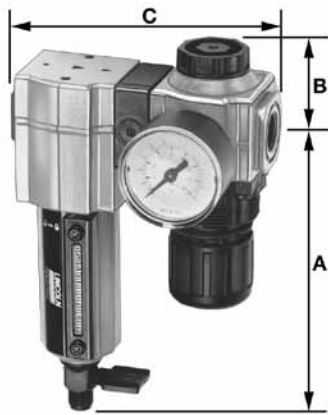

Modular Air Line Combination Units

Filter-Regulator with Gauge

Part No.	Maximum Air Supply	Operating Temperature Range	Element Particle Size	Outlet Pressure Adj. Range
85388-4	250 psig / 17 bar	0° to 150°F / -18° to 65°C	40μ	5 to 150 psig / 0.3 to 10 bar
85388-8		0° to 175°F / -18° to 79°C		

* Transparent nylon liquid level indicator lens.

Part No.	Drain Type	Port Size PTF	Dimensions - in. / mm			Weight lbs. / kg
			A	B	C	
85388-4	Manual	¼	5.27 / 134	1.31 / 33	4.22 / 108	2.0 / 1.0
85388-8		½	6.95 / 177	1.69 / 43	6.84 / 174	4.2 / 2.0



Modular Air Line Combination Units

Filter-Lubricator

Part No.	Maximum Air Supply	Operating Temperature Range	Element Particle Size	Lubricator Bowl Capacity ozs. / ml
85389-8	250 psig / 17 bar	0° to 175°F / -18° to 79°C	40μ	7.0 / 207

* Transparent nylon liquid level indicator lens.

Part No.	Drain Type	Port Size PTF	Dimensions - in. / mm			Weight lbs. / kg
			A	B	C	
85389-8	Manual	½	6.95 / 177	2.12 / 53	6.84 / 174	3.8 / 1.7



High-Capacity Air Line Filters

Part No.	Maximum Air Supply	Operating Temperature Range	Material of Construction		Element	
			Body	Bowl	Material	Particle Size
602112	250 psig / 17 bar	0° to 175°F / -18° to 79°C	Aluminum	Aluminum* w/ Pyrex sight glass	Sintered Bronze	50μ
602113						
602116						
602117						

* Pyrex liquid level indicator.

Part No.	Drain Type	Port Size PTF	Dimensions - in. / mm				Weight lbs. / kg
			A	B	C	Dia.	
602112	Manual	¼	10.44 / 265	1.25 / 32	4.75 / 121	5.52 / 140	4.1 / 1.9
602113	Automatic		10.06 / 256				
602116	Manual	1	10.44 / 265				
602117	Automatic		10.06 / 256				

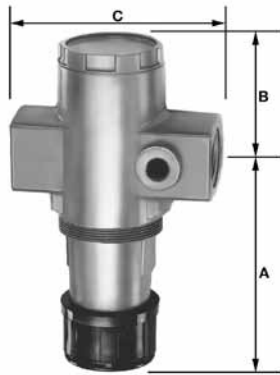

High-Capacity Air Line Regulators

Part No.	Maximum Air Supply	Operating Temperature Range	Material of Construction				Secondary (Gauge) Connections in.
			Body	Bonnet	Valve Seals	Bottom Plug	
602012 602013 602016	300 psig / 20 bar	0° to 175°F / -18° to 79°C	Aluminum	Aluminum	Aluminum / Nitrile	Aluminum	¼ NPT (F)

Part No.	Outlet Press. Adj. Range psig / bar	Connections NPT-Female in.	Dimensions - in. / mm				Adjuster	Weight lbs. / kg
			A	B	C	D		
602012	10 to 250 / 0.7 to 16	¾	5.69/145	2.38/ 60	4.25/ 108	2.38/ 60	T-Handle	2.5 / 1.1
602013	5 to 150 / 0.3 to 10		4.71/120				Knob	
602016	10 to 250 / 0.7 to 16	1	5.69/145	T-Handle				



High-Capacity Air Line Lubricators

Part No.	Maximum Air Supply	Operating Temperature Range	Material of Construction			Recommended Lubricants
			Body	Bowl	Sight feed Dome	
602212 602216	250 psig / 17 bar	0° to 175°F / -18° to 79°C	Aluminum	Aluminum*	Transp. Nylon	Misting type oil 50 to 200 SSU (ISO Grade 7 to 46) at 100°F (38°C)

* Pyrex liquid level indicator.

Part No.	Connections NPT-Female in.	Bowl Capacity ozs. / ml	Dimensions - in. / mm				Weight lbs. / kg
			A	B	C	Dia.	
602212	¾	32 / 946	10.24 / 260	2.22 / 56	4.50 / 114	5.52 / 140	3.6 / 1.6
602216	1						

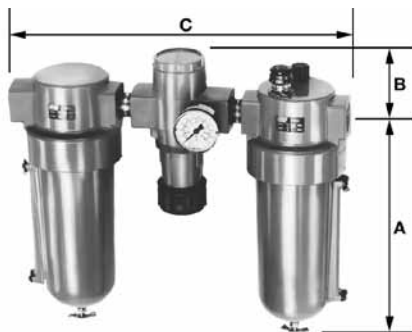

High-Capacity Air Line Combination Units

High-Capacity Filter-Regulator with Gauge-Lubricator

Part No.	Maximum Air Supply	Operating Temperature Range	Element Particle Size	Outlet Pressure Adj. Range	Lubricator Bowl Capacity ozs. / ml
85387-12 85387-16	250 psig / 17 bar	0° to 175°F / -18° to 79°C	50µ	5 to 125 psig / 0.3 to 8.6 bar	32 / 946

* Pyrex liquid level indicator.

Part No.	Drain Type	Port Size PTF	Dimensions - in. / mm			Weight lbs. / kg
			A	B	C	
85837-12	Manual	¾	10.44 / 265	2.22 / 56	14.75 / 375	10.6 / 4.8
85837-16	Manual	1				



High-Capacity Air Line Combination Units

Filter-Regulator with Gauge

Part No.	Maximum Air Supply	Operating Temperature Range:	Element Particle Size	Outlet Pressure Adj. Range
85388-12	250 psig / 17 bar	0° to 175°F / -18° to 79°C	50μ	5 to 125 psig / 0.3 to 8.6 bar

* Pyrex liquid level indicator.

Part No.	Drain Type	Port Size PTF	Dimensions - in. / mm				Weight lbs. / kg
			A	B	C	Dia.	
85388-12	Manual	¾	10.44 / 265	2.38 / 60	10 / 254	5.52 / 140	6.9 / 3.1



High-Capacity Air Line Combination Units

Filter-Lubricator

Part No.	Maximum Air Supply	Operating Temperature Range:	Element Particle Size	Lubricator Bowl Capacity ozs. / ml
85389-12	250 psig / 17 bar	0° to 175°F / -18° to 79°C	50μ	32 / 946
85389-16				

* Pyrex liquid level indicator.

Part No.	Drain Type	Port Size PTF	Dimensions - in. / mm				Weight lbs. / kg
			A	B	C	Dia.	
85389-12	Manual	¾	10.44 / 265	2.22 / 56	10.25 / 260	5.52 / 140	7.8 / 3.5
85389-16		1					



Miniature Air Line Components—Air Line Filter

Part No.	Maximum Air Supply	Operating Temperature Range:	Material of Construction		Element	
			Body	Bowl	Material	Particle Size
602103	150 psig / 10 bar	0° to 125°F / -18° to 52°C	Zinc	Polycarbonate	Porous Polypropylene	50μ

Part No.	Drain Type	Port Size PTF	Dimensions - in. / mm				Weight lbs. / kg
			A	B	C	Dia.	
602103	Manual	¾	3.25 / 83	0.38 / 10	1.63 / 42	1.45 / 37	1.1 / 0.12



Miniature Air Line Components— Air Line Regulator

Part No.	Maximum Air Supply	Operating Temperature Range	Material of Construction				Secondary (Gauge) Connections - in.
			Body	Bonnet	Valve Seals	Bottom Plug	
602003	300 psig / 20 bar	0° to 150°F / -18° to 65°C	Zinc	Acetal	Brass/ Nitrile	Acetal	½ NPT (F)

Part No.	Outlet Pressure Adj. Range	Connections NPT-Female in.	Dimensions - in. / mm				Adjuster	Weight lbs./kg
			A	B	C	D		
602003	5 to 100 psig / 0.3 to 7 bar	¼	2.52 / 64	0.39 / 10	1.63 / 41	1.45 / 37	Knob	0.3 / 0.13



Miniature Air Line Components— Air Line Lubricator

Part No.	Maximum Air Supply	Operating Temperature Range:	Material of Construction			Recommended Lubricants
			Body	Bowl	Sight feed Dome	
602203	150 psig / 10 bar	0° to 125°F / -18° to 52°C	Aluminum	Polycarbonate	Transp. Nylon	Misting type oil 50 to 200 SSU (ISO Grade 7 to 46) at 100°F (38°C)

Part No.	Connections NPT-Female in.	Bowl Capacity ozs. / ml	Dimensions - in. / mm				Weight lbs. / kg
			A	B	C	Dia.	
602203	¼	1.0 / 30	3.25 / 83	1.98 / 50	1.63 / 41	1.45 / 37	0.3 / 0.13

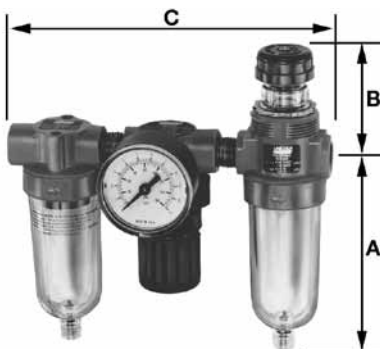

Miniature Air Line Combination Units

Filter-Regulator with Gauge-Lubricator

Part No.	Maximum Air Supply	Operating Temp. Range	Element Particle Size	Outlet Pressure Adj. Range	Lubricator Bowl Capacity ozs. / ml
85672	150 psig / 10 bar	0° to 150°F / -18° to 65°C	50µ	5 to 100 psig / 0.3 to 6.9 bar	1.0 / 30

Part No.	Drain Type	Port Size PTF	Dimensions - in. / mm				Weight lbs. / kg
			A	B	C	Dia.	
85672	Manual	¼	3.25 / 83	1.98 / 50	5.61 / 143	1.45 / 37	1.3 / 0.6



Miniature Air Line Combination Units

Filter-Lubricator

Part No.	Maximum Air Supply	Operating Temperature Range	Element Particle Size	Lubricator Bowl Capacity ozs. / ml
85674	150 psig / 10 bar	0° to 125°F / -18° to 52°C	5μ	1.0 / 30

Part No.	Drain Type	Port Size PTF	Dimensions - in. / mm				Weight lbs. / kg
			A	B	C	Dia.	
85674	Manual	¼	3.25 / 83	1.98 / 50	3.66 / 93	1.45 / 37	0.9 / 0.4

Modular Air Line Equipment Accessories—Lockout Valve

Install in-line or modular with other AirCare products to help conform to OSHA Lockout Regulations. In the closed position, valves block inlet air flow and exhaust downstream air.



Part No.	For Modular use with	For In-Line use with	Maximum Air Supply	Operating Temperature Range:
247770	¼" Modular	¼"	250 psig / 17 bar	0° to 150°F / -20° to 65°C
247771	⅜" Modular	⅜"		
247772	½" Modular	½"		

Modular Air Line Equipment Accessories—Quick Clamp

Use with Modular Air Line Components to provide modular installation capability. Flanges on the products slide into "V" grooves in the quick clamp. Two face-sealing O-rings in the quick clamp provide an air tight connection when the clamp is closed.



Part No.	For Modular Sizes	Dimensions in. / mm
247782	¼" and ⅜"	1.50 / 38
247783	½" and ¾"	2.00 / 51

Modular Air Line Equipment Accessories—Quick Clamp Wall Mounting Bracket

Use with quick clamp to provide secure mounting to a wall, machine panel or other flat surface.

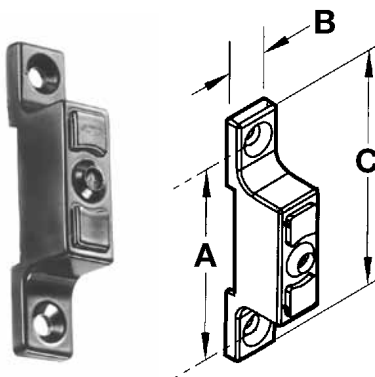

Part No.	For Modular Sizes	Dimensions - in. / mm		
		A	B	C
247792	¼" and ⅜"	2.32 / 59	0.55 / 14	2.91 / 74
247793	½" and ¾"	3.25 / 83	0.95 / 24	4.0 / 102



Modular Air Line Equipment Accessories— Quick Mount Pipe Adapters

Use with quick clamp to provide threaded connections to the system piping.

Part No.	For Modular use with	Port Size - in.
247787	3/8" Modular	3/8
247789	1/2" and 3/4" Modular	
247791		3/4

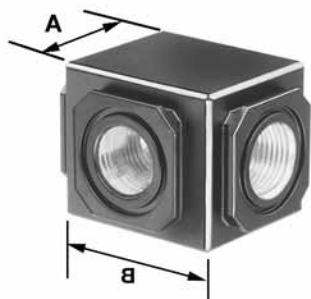

Modular Air Line Equipment Accessories— Manifold Block

Installs with quick clamps. Ports are threaded pipe to provide manifolding capability for up to three components.

Part No.	Port Size in.	For Modular Sizes	Dimensions - in. / mm	
			A	B
247795	3/4	1/2" and 3/4"	2.27 / 57.8	3.15 / 80



Modular Air Line Equipment Accessories— Tamper Resistant Cover & Seal Wire

Install on the adjusting knob of regulators to help prevent unauthorized adjustment of the pressure setting.

Part No.	For Modular Sizes
247778	1/2" and 3/4"



Modular Air Line Equipment Accessories— Wall Mount Bracket

Use to secure Modular Air Line components to a wall, machine panel or other flat surface.

Part No.	For Modular Sizes
247775	1/4" and 3/8"
247776	1/2" and 3/4"



Modular Air Line Equipment Accessories— Pressure Switch

Monitors air pressure and provides an electrical signal when the pressure drops below or exceeds the preset pressure. Installs between two quick clamps. Also provides three additional 1/4" auxiliary outlets.

Part No.	For Modular Sizes	Maximum Inlet Pressure psi / bar	Operating Temperature Range	Adjustment Range psi / bar
247797	1/2" and 3/4"	250 / 17	0° to 150°F / -20° to 65°C	30 to 150 / 2 to 10



Air Line Equipment Accessories—Mounting Bracket and Nut—Miniature

Use to secure Miniature Air Line components to a wall, machine panel or other flat surface.

Part No.	Component
247774	All Regulators and Lubricators



Air Line Equipment Accessories—Pressure Gauges

Available in 1/8" NPT and 1/4" NPT back connection.

Part No.	For Regulator Sizes	Gauge Diameter	Connection	Pressure Range
247843	1/4" and 3/8"	1 1/2"	1/8" NPT	0 to 160 psig / 0 to 11
247844	1/2", 3/4" and 1"	2"	1/4" NPT	0 to 300 psig / 0 to 20 bar
247863				0 to 300 psig / 0 to 20 bar



Manual Shut-Off Valves—High-Pressure Needle Valves

For supply lines.

Part No.	Inlet/Outlet Female NPTF(F)	Dimension		Max. Working Pressure
		A (Valve Open) in. / cm	B in. / cm	
778	1/4"	3 1/16 / 7.8	2 1/2 / 6.4	10000 psig / 680 bar
884	3/8"	3 3/4 / 9.5	2 7/8 / 7.3	
885	1/2"	3 3/4 / 9.5	2 7/8 / 7.3	



Manual Shut-Off Valves—Quarter-Turn Valves

For supply lines.

Part No.	Connections Female NPTF(F)	Dimension		Max. Working Pressure
		A in. / cm	B in. / cm	
69503	1/2"	6 1/32 / 15.3	1 5/8 / 4.1	3000 psi / 206 bar
69425	3/4"	6 7/32 / 15.6	2 7/8 / 7.3	
69423	1"	7 9/32 / 19.3	4 1/4 / 10.8	



Manual Shut-Off Valves—Low-Pressure Quarter-Turn Valves

Part No.	Inlet/Outlet NPTF (F) in.	Max. Working Pressure
66084	1/2	710 psig / 48 bar
256200	1/4	300 psig / 20 bar



Pressure Gauges—High-Pressure Gauges

For lubricant supply lines.

Part No.	Maximum Register	Indicator Needle	Dial Diameter in. / mm	Size in.	Location
66689	2000 psig / 140 kg/cm ²	Single	2½ / 65	¼ NPT(M)	Bottom
68946		Dual			
69844	3000 psig / 210 kg/cm ²	Single	3½ / 88.9		Bottom
69827					
66111	5000 psig / 350 kg/cm ²	Dual	2½ / 65		
69039					



Pressure Gauges—Low-Pressure Gauges

For air lines.

Part No.	Maximum Register	Indicator Needle	Dial Diameter in.	Connection	
				Size in.	Location
66100	200 psig / 14 kg/cm ²	Single	2	¼ NPT(M)	Bottom
600401					Back Center
66101				¼ NPT(M)	Bottom



Lubricant Filters

Remove solid contaminants before delivering lubricants to the supply line. Filters mount in pump outlet before vent valve on reciprocating pump systems.

Part No.	Element Size micron	Maximum Pressure:	Connections in.	Hex Body Size - in.
84004	140	5000 psig / 340 bar	½ NPTF (M)	¼

* In-line filter with fluoroelastomer seal.



Lubricant Strainers

Remove solid contaminants before delivering lubricants to the supply line. Strainers mount at pump inlet.

Part No.	Use with Pump/Model Type	Strainer Size
82103	Series 20 Models 1823/282288	500 Micron

Note: Not recommended for use with heavy lubricants.

Decimal Equivalents

Fraction	Decimal	mm	Fraction	Decimal	mm
1/64	.01563	.40	33/64	.51563	13.1
1/32	.03125	.80	17/32	.53125	13.5
3/64	.04687	1.2	35/64	.54688	13.9
1/16	.0625	1.6	9/16	.56250	14.3
5/64	.07813	2.0	37/64	.57813	14.7
3/32	.09375	2.4	19/32	.59375	15.1
7/64	.10937	2.8	39/64	.60938	15.5
1/8	.125	3.2	5/8	.625	15.9
9/64	.14063	3.6	41/64	.64063	16.3
5/32	.15625	4.0	21/32	.65625	16.7
11/64	.17188	4.4	43/64	.67188	17.1
3/16	.1875	4.8	11/16	.6875	17.5
13/64	.20313	5.2	45/64	.70313	17.9
7/32	.21875	5.6	23/32	.71875	18.3
15/64	.23438	6.0	47/64	.73438	18.7
1/4	.25	6.4	3/4	.750	19.1
17/64	.26563	6.7	49/64	.76563	19.4
9/32	.28125	7.1	25/32	.78125	19.8
19/64	.29688	7.5	51/64	.79688	20.2
5/16	.3125	7.9	13/16	.8125	20.6
21/64	.32813	8.3	53/64	.82813	21.0
11/32	.34375	8.7	27/32	.84375	21.4
23/64	.35938	9.1	55/64	.85938	21.8
3/8	.375	9.5	7/8	.875	22.2
25/64	.39063	9.9	57/64	.89063	22.6
13/32	.40625	10.3	29/32	.90625	23.0
27/64	.42188	10.7	59/64	.92188	23.4
7/16	.4375	11.1	15/16	.9375	23.8
29/64	.45313	11.5	61/64	.95313	24.2
15/32	.46875	11.9	31/32	.96875	24.6
31/64	.48438	12.3	63/64	.98138	25.0
1/2	.50	12.7	1	1.0000	25.4

Note:

1 inch = 25.4 millimeters

To convert decimals to millimeters multiply by 25.4

Example: 1/4" = .250"

.250" x 25.4 = 6.35 mm

To convert millimeters to decimals, divide by 25.4

Example: 6.35 mm 25.4 = .250" = 1/4"

Installation Components

Numerical Index



Part No.	Page No.
G904	12
G905	12
226-12508-5	15
226-13095-7	15
304-19164-1	38
304-19165-1	38
304-19166-1	38
432-24313-1	18
778	49
884	49
885	49
5000	5, 20, 21
5000-1	21
5000-9	9, 21
5000C	20
5003	5, 21
5003C	20
5009	5, 21
5010	4, 20, 21
5010-1	4
5010-9	9, 21
5010C	20
5013	4, 21
5013C	20
5014	4, 21
5031	8, 21
5031C	20
5033	8, 20, 21
5033-9	9, 21
5033C	20
5036	8, 21
5045	21
5050	6, 21
5050C	20
5099	10, 21
5175	6
5175C	20
5176	6
5176C	20
5177	6
5177C	20
5178	6
5178C	20
5179	6
5179C	20
5180	6
5180C	20
5181	6
5181C	20
5182	6
5182C	20
5183	6
5183C	20

Part No.	Page No.
5200	5, 20, 21
5200C	20
5210	4, 20, 21
5210C	20
5300	5, 21
5300C	20
5308	5, 21
5318	8, 21
5350	6, 21
5350C	20
5385	8, 21
5385C	20
5400	5, 20, 21
5400C	20
5410	4, 20, 21
5410-9	9, 21
5410C	20
5505	5, 21
5527	4, 21
5527C	20
5677	10, 21
5678	10, 21
5679	10, 21
5680	10, 21
5698	10, 21
5701	10, 20, 21
5701C	20
5706	10, 20, 21
5706C	20
5711	10, 21
10049	35
10130	35
10182	11
10198	35
10199	35
10200	35
10202	35
10204	35
10460	10
10461	35
10462	35
10462-9	35
10522	36
10540	35
10772	35
10773	35
11107	35
11197	35
11229	35
11348	35
11485	12
11509	12
11852	36

Installation Components

Numerical Index



Part No.	Page No.
12080	35
12106	35
12138	40
12287	35
12422	40
12511	11
12613	33
12613-9	33
12614	33
12614-9	33
12615	33
12615-9	33
12720	33
12957	35
12989	35
13003	33
13112	18, 29
13129	11
13147	14
13148	14
13154	11, 16, 21
13155	11, 16, 21
14054	11, 16
14562	14
14563	14
14564	14
14570	14
14727	35
14771	14
14772	14
20011	16, 35
20012	38
20024	11, 16, 21, 38
20026	11, 21, 38
20028	11, 21, 38
20029	11, 21, 38
20031	11, 21, 38
31138	10
50057	15
50521	40
51026	15
51055	16
51304	15
62175	15, 22
62176	15, 22
62249	22
62256	22
62278	22
62357	15, 22
62948-9	22
62949-9	22
62950-9	22
62956	22

Part No.	Page No.
64532	19
64532-1	19, 23
64532-2	19, 23
64532-3	19, 23
64532-4	19, 23
64532-5	19, 23
64533	19
64533-1	18, 23
64533-2	18, 23
64533-3	18, 23
64533-4	18, 23
64533-5	18, 23
66084	49
66100	50
66101	50
66111	50
66200	17, 26
66201	17, 26
66202	19, 23
66202-9	23
66210	26
66211	26
66260	17, 28
66260-9	28
66414	17, 28
66415	17, 28
66645	37
66648	38
66649	16, 32, 37
66650	27
66651	26
66689	50
66713	18, 28, 29
66714	17, 28
66714-9	28
66716	17, 28
66717	16, 17, 39
66717-9	39
66730	28
66762	26
66771	28
66772	28
66773	28
66842	37
66844	33
66846	26
66872	23
66872-9	23
66876	26
66878	27
66883	37
66935	28
67011	36

Installation Components

Numerical Index



Part No.	Page No.
67054.....	36
67062.....	36
67063.....	36
67069.....	35
67074.....	36
67094.....	36
67102.....	36
67102-9.....	36
67132.....	16
67171.....	35
67176.....	36
67179.....	36
67198.....	35
67296.....	36
67358.....	36
67360.....	36
67362.....	37
67368.....	36
67368-9.....	36
67371.....	35
67374.....	27
67448.....	36
68412.....	26
68414.....	26
68415.....	26
68462.....	17, 27
68463.....	27
68464.....	17, 27
68468.....	27
68511.....	19
68535.....	19
68615.....	26
68943.....	26
68946.....	50
68987.....	19
69039.....	50
69068.....	24
69068-9.....	24
69069.....	24
69069-9.....	24
69070.....	24
69071.....	24
69072.....	24
69078.....	24
69079-9.....	24
69082.....	24
69082-9.....	24
69084.....	24
69085.....	24
69089.....	25
69093.....	25
69094.....	25
69095.....	25

Part No.	Page No.
69098.....	25
69099.....	25
69159-9.....	23
69160-9.....	23
69161-9.....	23
69163-9.....	23
69164-9.....	23
69165-9.....	23
69166-9.....	26
69169-9.....	23, 26
69170-9.....	27
69171-9.....	27
69375.....	37
69423.....	49
69425.....	49
69503.....	49
69827.....	50
69844.....	50
71900.....	32, 33
71908.....	32
71912.....	32
71918.....	32
72024.....	33
72024A.....	33
72036.....	33
72060.....	33
72120.....	33
72240.....	33
72360A.....	33
72480.....	33
72480A.....	33
72600.....	33
72600A.....	33
72720A.....	33
73024.....	31
73036.....	31
73060.....	31
73120.....	31
73240.....	31
73360.....	31
73480.....	31
73600.....	31
73900.....	31
74024.....	33
74060.....	33
74480.....	33
74600.....	33
75024.....	31
75060.....	31
75084.....	31
75120.....	31
75168.....	31
75240.....	31

Installation Components

Numerical Index



Part No.	Page No.
75360	31
75480	31
75600	31
75948	31
75960	31
76024A	31
76024B	31
76600A	31
76600B	31
76900B	31
79060	31
81386	39
81387	39
81458	10
81583	40
81606	39
81712-18	32
81712-24	32
81712-30	32
81712-36	32
81712-6	32
81712-8	32
81723	39
81728	38
81729	39
81974	39
82072	38
82073	39
82080	38
82087	39
82092	28
82093	28
82103	50
82225	40
82226	40
82238-12	32
82238-18	32
82238-24	32
82239-12	32
82239-18	32
82239-24	32
82251	39
82252	39
82617	18, 29
82618	18, 29
83594	39
83722	39
83822	39
83938	38
84004	50
85387-12	44
85387-16	44
85387-4	42

Part No.	Page No.
85387-6	42
85387-8	42
85388-12	45
85388-4	43
85388-8	43
85389-12	45
85389-16	45
85389-8	43
85672	46
85674	47
91048	16, 39
91048-9	39
91308	16, 39
92131	39
205000	7, 21
205010	7, 21
205200	7, 21
205210	7, 21
205400	7, 21
205410	7, 21
240646	21
241054	19
241055	19
241056	19
241110	19
241120	19
241238	16
241286	15
241287	15
241288	15
241289	15, 16, 22
241290	18
241293	18
241388	18, 29
241389	18, 29
242025	15
242050	15
242125	19
243373	36
243699	18, 30
244047	18, 30
244048	18, 30
244053	18, 30
244054	18, 30
244055	18, 30
244056	30
244057	30
244058	18, 30
246002	15, 16, 22
247022	15, 22
247235	7
247615	17
247616	11, 38

Installation Components

Numerical Index



Part No.	Page No.
247770.....	47
247771.....	47
247772.....	47
247774.....	49
247775.....	48
247776.....	48
247778.....	48
247780.....	48
247782.....	47
247783.....	47
247787.....	48
247789.....	48
247791.....	48
247792.....	47
247793.....	47
247795.....	48
247797.....	48
247843.....	49
247844.....	49
247863.....	49
249848.....	23, 40
249849.....	23, 40
249850.....	40
249851.....	40
249853.....	23
249913.....	23
249987.....	40
252717.....	15
252807.....	40
256200.....	49
270784.....	17
270928.....	40
270931.....	23
272394.....	16, 18
272401.....	16, 18
272427.....	16
272598.....	23
272658.....	18
272659.....	18
273482.....	16
274047.....	15
274048.....	15
274049.....	15
274050.....	15
274062.....	16
274097.....	19
274098.....	19
274099.....	19

Part No.	Page No.
274238.....	16
274239.....	18
360108.....	23
600401.....	50
602003.....	46
602004.....	41
602005.....	41
602006.....	41
602007.....	41
602008.....	41
602009.....	41
602012.....	44
602013.....	44
602016.....	44
602103.....	45
602104.....	41
602106.....	41
602108.....	41
602109.....	41
602112.....	43
602113.....	43
602116.....	43
602117.....	43
602134.....	42
602136.....	42
602138.....	42
602203.....	46
602204.....	42
602206.....	42
602208.....	42
602212.....	44
602216.....	44
645006.....	34
653112.....	34
655008.....	34
655012.....	34
660112.....	34
662012.....	34
700337.....	11
700396.....	4
700502.....	8
700504.....	8
700506.....	10
1230120.....	31

A complete line of lubrication solutions and industrial pumping products



At every construction site, automobile repair shop and industrial plant, maintenance and automotive service professionals need high-quality lubrication equipment and pumping products.

Lincoln offers everything you need for lubrication. Our general-purpose and heavy-duty pumps, hose reels, meters and controls, used fluid systems and hand-held lubrication products are the best in the industry.



MFP **AUTOMATION** **ENGINEERING**

©SKF is a registered trademark of the SKF Group.

©Lincoln is a registered trademark of Lincoln Industrial Corp.

©SKF Group 2015

The contents of this publication are the copyright of the publisher and may not be reproduced (even extracts) unless prior written permission is granted. Every care has been taken to ensure the accuracy of the information contained in this publication but no liability can be accepted for any loss or damage whether direct, indirect or consequential arising out of the use of the information contained herein.

July 2015 · FORM 442836

