

Lubricant distributors

Product series AB, 341, 340, 351, 350, 391, 390, VR, 321, VN, 370, 361

For oil, fluid grease, and grease

For use in SKF MonoFlex single-line centralized lubrication systems



SKF MonoFlex single-line distributors are utilized in intermittently operated single-line centralized lubrication systems.

They distribute and meter the lubricant fed by an intermittently operated centralized lubrication pump unit in SKF MonoFlex single-line centralized lubrication systems. In each lubrication cycle, a precisely metered quantity of lubricant, ranging from a minimum of 0,01 to a maximum of 1,5 cm³, is fed to the connected lubrication points.

The product group of SKF MonoFlex single-line distributors includes a total of 11 different product series consisting of three different functional types (prelubrication, relubrication, and dynamic distributors) for various applications. Comprehensive accessories complete the product range.

Depending on the design, SKF MonoFlex single-line distributors are approved for oils with viscosities from 20 to 2 000 mm²/s, for fluid greases of NLGI Grade 000, 00, and 0, and greases up to NLGI Grade 2. The permissible operating pressures range from 8 to 315 bar, and the relief pressures range from 1 to 70 bar.

In addition to the standard designs, several designs are also available in stainless steel. Further, several designs are also certified by Germanischer Lloyd with regard to corrosion resistance.

Due to the variety of available products, SKF MonoFlex single-line distributors can be used in numerous applications, including machine tools and the wind, print, textile, and vehicle and construction industries.





Important information on product usage

SKF and Lincoln lubrication systems or their components are not approved for use with gases, liquefied gases, pressurized gases in solution and fluids with a vapor pressure exceeding normal atmospheric pressure (1 013 mbar) by more than 0,5 bar at their maximum permissible temperature.

Contents

Important information on product usage	2
Product overview	4
Selection table	5
Description of functional types	
MonoFlex prelubrication distributors	6
MonoFlex relubrication distributors	7
MonoFlex dynamic distributors	8
SKF MonoFlex system structure	
Prelubrication, relubrication, and dynamic distributor system	9
Important notes	10
SKF MonoFlex MonoFlex connector systems	
Overview	11
SKF quick connectors	12
Solderless pipe connections	14
Pipe and hose lines	15
Steel pipelines	16
Plastic pipelines	17
Low-pressure hose lines for main lines and secondary lines	18
Low-pressure hose lines with cover braid for main lines and secondary lines	19
Low-pressure hose lines for lubrication point lines	20
High-pressure hose lines	21
SKF MonoFlex prelubrication distributors	
Product series AB	
General/Technical data	22
Configurator	23
Dimensions/Accessories	24
Manifolds	25
Product series 341	
General/Technical data	26
Configurator	27
Dimensions/Accessories	28
Manifolds	29
Product series 340	
General	30
Configurator	31
Dimensions	32
Technical data/Accessories	33
Product series 351	
General/Technical data	34
Configurator	35
Dimensions/Accessories	36
Manifolds	37
Product series 350	
General	38
Configurator	39
Dimensions	40
Technical data/Accessories	41
Product series 391	
General/Technical data	42
Configurator	43
Dimensions/Accessories	44
Manifolds	45
Product series 390	
General	46
Configurator	47
Dimensions	48
Technical data/Accessories	49
Product series VR	
General	50
Configurator	51
Dimensions	52
Dimensions/Technical data	53
Product series 321	
General	54
Order numbers	55
Dimensions	56
Technical data	57
SKF MonoFlex relubrication distributors	
Product series VN	
General	58
Configurator	59
Dimensions	60
Technical data/Accessories	61
Product series 370	
General	62
Configurator	63
Dimensions	64
Technical data/Accessories	65
SKF MonoFlex dynamic distributors	
Product series 361	
General	66
Configurator	67
Dimensions/Technical data	68
Manifolds	69

Product overview

SKF MonoFlex prelubrication distributors

SKF MonoFlex prelubrication distributors for direct connection to the lubrication point



SKF MonoFlex relubrication distributors

SKF MonoFlex dynamic distributors



Selection table

SKF MonoFlex single-line distributors																				
Product series	Lubricant	Distributor type	Elastomer material	Number of metering points	Relief pressure ≤ [bar]	Metered quantity [cm ³]										Page				
						0,01	0,02	0,03	0,05	0,06	0,10	0,20	0,30	0,40	0,60		0,80	1,00	1,30	1,50
AB	Oil Fluid grease ²⁾	Prelubrication distributor	FKM (FPM)	1	3	•	•	•												22
		Prelubrication distributor	FKM (FPM)	1	3	•	•	•												
341	Oil Fluid grease ²⁾	Prelubrication distributor	NBR / FKM (FPM)	1	1 (3) ¹⁾	•	•	•		•	•									26
		Prelubrication distributor	NBR / FKM (FPM)	1	3			•		•	•									
340	Oil Fluid grease ²⁾	Prelubrication distributor	NBR / FKM (FPM)	2, 3, 5	1 (3) ¹⁾	•	•	•		•	•									30
		Prelubrication distributor	NBR	2, 3, 5	3			•		•	•									
351	Oil Fluid grease ²⁾	Prelubrication distributor	NBR / FKM (FPM)	1	1				•	•	•	•	•							34
		Prelubrication distributor	NBR / FKM (FPM)	1	3					•	•	•	•							
350	Oil Fluid grease ²⁾	Prelubrication distributor	NBR / FKM (FPM)	2, 3, 5	1				•	•	•	•	•							38
		Prelubrication distributor	NBR / FKM (FPM)	2, 3, 5	3					•	•	•	•							
391	Oil Fluid grease	Prelubrication distributor	NBR / FKM (FPM)	1	1							•	•	•					•	42
		Prelubrication distributor	NBR	1	7							•	•	•						
390	Oil Fluid grease	Prelubrication distributor	NBR / FKM (FPM)	2, 3	1							•	•	•					•	46
		Prelubrication distributor	NBR	2, 3	7							•	•	•						
VR	Fluid grease Grease	Prelubrication distributor	FKM (FPM)	1 – 12	30 / 70						•	•	•	•	•	•	•	•	•	50
		Prelubrication distributor	FKM (FPM)	1 – 12	30 / 70						•	•	•	•	•	•	•	•	•	
321 G	Oil / fluid grease ²⁾	Prelubrication distributor	NBR	1	3		•	•		•	•									54
321 T	Oil / fluid grease ²⁾	Prelubrication distributor	NBR	1	3		•	•		•	•									54
321 W	Oil / fluid grease ²⁾	Prelubrication distributor	NBR	1	3		•	•		•	•									54
321 Module	Oil / fluid grease ²⁾	Prelubrication distributor	NBR	1	3		•	•		•	•									54
321 G4	Oil / fluid grease ²⁾	Prelubrication distributor	NBR	1	3			•		•	•									54
321 G7	Oil / fluid grease ²⁾	Prelubrication distributor	NBR / FKM (FPM)	1	3			•		•	•	•	•	•						54
VN	Fluid grease ²⁾	Relubrication distributor	NBR	2, 4, 6	1				•	•	•	•	•	•					•	58
370	Oil	Relubrication distributor	NBR	2, 3, 5	1				•	•	•	•	•	•					•	62
361	Oil Fluid grease ²⁾	Dynamic distributor	NBR	1	1			•	•	•	•									66
		Dynamic distributor	NBR	1	3		•	•	•		•	•								

¹⁾ Relief pressure of 3 bars is only valid for the metered quantity 0,01 cm³ and 0,02 cm³
²⁾ Only fluid grease of NLGI Grades 000, 00

The table above will help you quickly find more information on the SKF MonoFlex single-line distributor that is required. You can quickly find the product series for your specific application according to feature. The product series are divided into three different functional types (prelubrication, relubrication, and dynamic distributors). The various product series are listed on the left margin. The metered quantities can be selected based on the required properties such as lubricant, distributor type, elastomer material, and number of metering points. The page numbers shown on the right margin refer to additional technical details for the product series in question. The individual metered quantities are visualized in relation to one another in the illustration to the right.

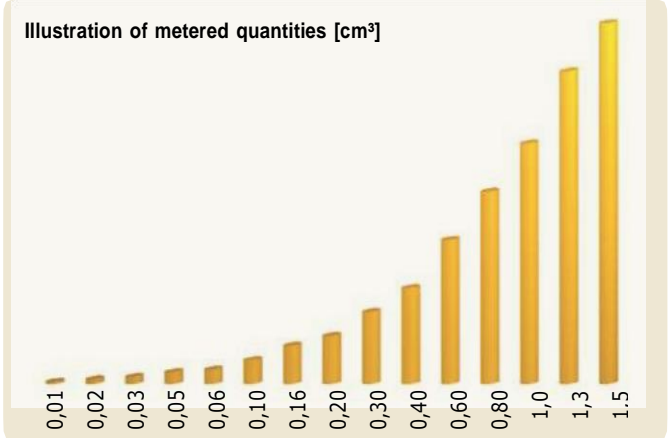

SKF MonoFlex single-line distributors

Description of functional types

Introduction

SKF MonoFlex single-line distributors are utilized in intermittently operated SKF MonoFlex centralized lubrication systems. Single-line centralized lubrication systems are total-loss lubrication systems.

These systems feed clean lubricant (oil, fluid grease, or grease) to one or more lubrication points at specific intervals during the lubrication cycle (timer-controlled or cycle-controlled). The lubricant fed to the lubrication point is partially consumed during operation due to aging, evaporation, and leaks. SKF MonoFlex single-line centralized lubrication systems generally consist of a lubrication unit, the single-line distributors, and the lubrication lines. The sequence of a lubrication cycle depends on the functional type of single-line distributors in use.

In single-line distributors, a differentiation is made between prelubrication, relubrication, and dynamic distributors. Single-line distributors of the prelubrication and dynamic distributor functional type deliver the metered quantity of lubricant at the same time that pressure is built up in the main line. Single-line distributors of the relubrication distributor functional type supply the metered quantity of lubricant after the pressure has been relieved in the procedure in the main line. The individual functional types are described below.

Prelubrication distributor

On SKF MonoFlex single-line distributors designed as prelubrication distributors, the quantity of lubricant is fed to the lubrication point while pressure is being built up in the main line, i.e., during the lubrication unit's run time. On prelubrication distributors, the expelling pressure can be set so it is approximately equal to the maximum permissible pressure of the pressure regulating valve on the lubrication unit.

After the lubrication unit is switched on, the lubricant is drawn out of the lubricant reservoir by the lubricant pump and fed through the main line to the prelubrication distributor via the pressure relief valve and the pressure regulating valve. The pressure built up in the centralized lubrication system causes the metering piston to move toward the outlet (2), expelling the lubricant (1) that is upstream of the metering piston from the metering chamber and to the lubrication point through the lubrication point line. After the lubrication unit is turned off, pressure in the centralized lubrication system is relieved, which relieves pressure in the main line. In this process, spring tension causes the metering piston to return to its normal position. At the same time, the lubricant is moved from the metering chamber into the spring chamber (3). The prelubrication distributor is ready for the next lubrication cycle.

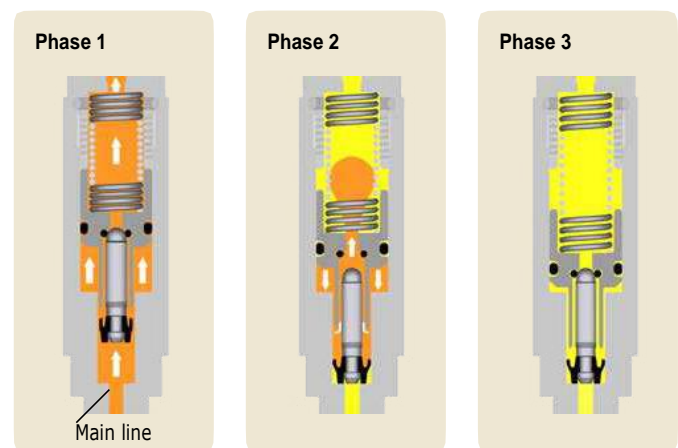

Area of application

Prelubrication distributors are used in applications where the lubricant needs to be delivered to the lubrication point immediately. Especially in the case of long lubrication point lines and high bearing back pressures, increasing the pressure in the main line can provide reliable lubrication of the bearing, as the expelling pressure approximately equals the pressure in the main line. Fields where prelubrication distributors are widely used is with machine tool, textile, and packaging machine lubrication.

SKF MonoFlex single-line distributors

Description of functional types

Relubrication distributor

On SKF MonoFlex single-line distributors designed as relubrication distributors, the quantity of lubricant is fed to the lubrication point only during or after pressure relief in the main line, i.e., after the lubrication unit is switched off.

The pressures with which lubricant can be expelled to the lubrication point are determined by the spring tension in the piston area, and they are lower than the maximum expelling pressure of the prelubrication distributors. The relubrication distributor thus has the function of a spring accumulator.

After the lubrication unit is switched on, the lubricant is drawn out of the lubricant reservoir by the lubricant pump and fed through the main line to the relubrication distributor via the pressure relief valve and the pressure regulating valve. The pressure built up in the centralized lubrication system causes the collar (shuttle valve) to close the outlet to the lubrication point, which feeds the lubricant into the storage chamber. The lubricant below the spring-loaded metering piston is stored (1). After the lubrication unit is turned off, pressure in the centralized lubrication system is relieved, which relieves pressure in the main line. The lubricant under preload below the spring-loaded metering piston now pushes the collar back toward the main line (2). This closes the main line and opens the outlet to the lubrication point. The lubricant can now be metered from the storage chamber and delivered to the lubrication point (relubrication effect). After the lubricant has been completely expelled to the lubrication point, the relubrication distributor is ready for the next lubrication cycle (3).

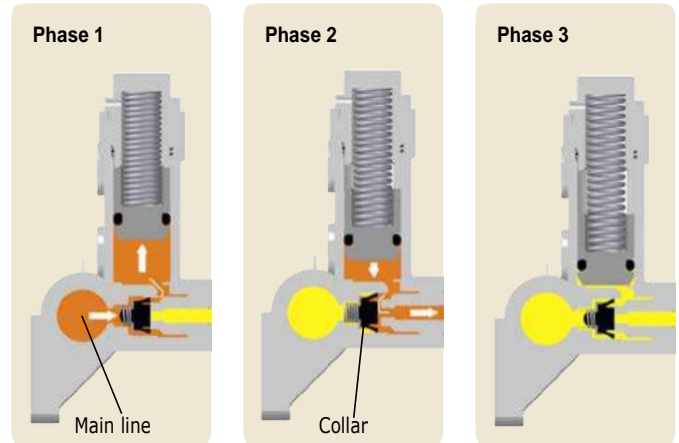

Area of application

Relubrication distributors are used in applications where an excessively high and sudden pressure at the lubrication point is undesirable, for example, when lubricating slideways on grinding machines. Such pressure at the lubrication point can lead to undesirable rough grinding results. The expelling time of the relubrication distributor depends on the back pressures in the lubrication point lines. If, for example, the lubrication points are under heavy load during the lubrication cycle, the lubricant will be stored in the relubrication distributor and only fed upon movement or when pressure on the lubrication point is relieved. For commercial vehicle lubrication, this mode of operation is a significant advantage over manual lubrication which cannot always be performed on pressure-loaded bearings.

SKF MonoFlex single-line distributors

Description of functional types

Dynamic distributor

On SKF MonoFlex single-line distributors designed as dynamic distributors, the quantity of lubricant is fed to the lubrication point while pressure is being built up in the main line, i.e., during the lubrication unit's run time. On dynamic distributors, the expelling pressure can be set approximately equal to the maximum permissible pressure of the pressure regulating valve on the lubrication unit.

After the lubrication unit is switched on, the lubricant is drawn out of the lubricant reservoir by the lubricant pump and fed through the main line to the dynamic distributor via the pressure relief valve and the pressure regulating valve. The unit's principle of operation requires that pressure be built up in the main line within a period < 1 s, i.e., pressure build-up in the main line must be sudden (dynamic). The pressure build-up dynamically in the centralized lubrication system causes the metering piston to move toward the check valve (2), expelling the lubricant (1) that is upstream of the metering piston. The check valve opens and the lubricant is expelled in the direction of the lubrication point until the lower valve seat closes. The lubricant continues to be fed toward the lubrication point until the check valve closes again. After the lubrication unit is turned off, pressure in the centralized lubrication system is relieved. In this process, the metering piston under spring preload returns to its normal position. At the same time, the lubricant is moved through the annular gap between the metering piston and piston chamber. The upper check valve prevents the lubricant from flowing back into the metering chamber from the lubrication point line. The dynamic distributor is ready for the next lubrication cycle (3).

The clearance between the piston and piston chamber must be sized to allow lubricant to flow through the annular gaps. This is also the reason for dynamic operation of dynamic distributors. If pressure were to build up slowly (statically) in the lubrication line, an unsteady state would occur in which the lubricant would flow to the lubrication point via the annular gap during the entire runtime of the lubrication unit. This would result in excessive lubrication of the lubrication point.

To increase the lubrication frequency, single-line centralized lubrication systems with dynamic distributors can be equipped with a 4/2 directional control valve. The single-line centralized lubrication system must be designed such that the main line is preloaded to approx. 6 bar when the lubrication unit is running. For the lubrication procedure, the 4/2 directional control valve is switched so that the dynamic distributors are suddenly pressurized. This layout allows a significant increase in the lubrication frequency, as required, for example for chain lubrication when using small chain links or at high chain speeds. This allows lubrication cycle frequencies of up to 5 cycles/second to be achieved using low-viscosity lubricants.

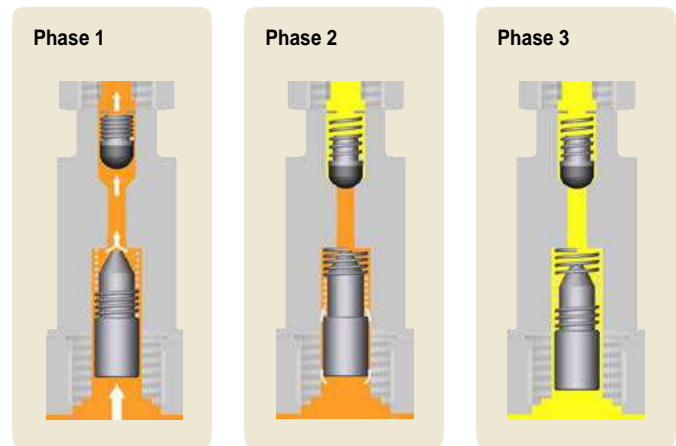

Area of application

Dynamic distributors are used in applications where the lubricant needs to be delivered to the lubrication point almost immediately. An important application for dynamic distributors is the lubrication of chains in machinery and conveyor belts.

SKF MonoFlex system structure

Prelubrication, relubrication, and dynamic distributor system

SKF MonoFlex single-line centralized lubrication systems with single-line distributors generally consist of a lubrication unit, the single-line distributors, and the lubrication lines. The pressure regulating valve and pressure relief valve required for the single-line centralized lubrication system's operation are normally integrated into the lubrication unit.

If pressure losses of greater than 10 bar are expected in the single-line centralized lubrication system, for example due to expansion of the system or due to the viscosity of the lubricant (depending on the ambient temperature), a pressure switch should be mounted to monitor the system at the end of the main line, if possible. The pressure switch monitors whether the required pressure build-up occurs in the single-line centralized lubrication system during the lubrication cycle.

The lubrication unit run time specified by the control unit or machine control unit ensures pressure build-up in the single-line centralized lubrication system. Pressure in the main line must be relieved after the lubrication unit is switched off to ensure proper functioning of the single-line distributors. This is performed by the pressure relief valve integrated into the lubrication unit.

See the following illustration for examples of single-line centralized lubrication systems with prelubrication, relubrication, and dynamic distributors.

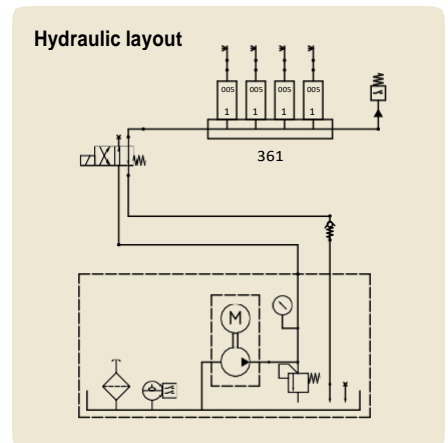
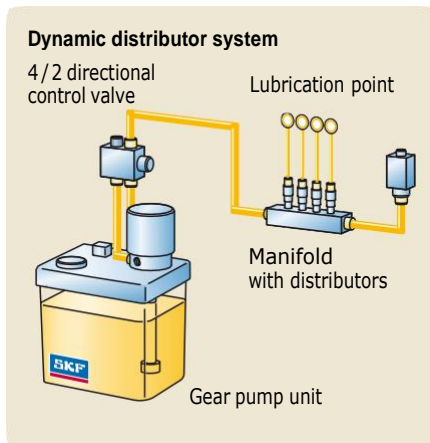
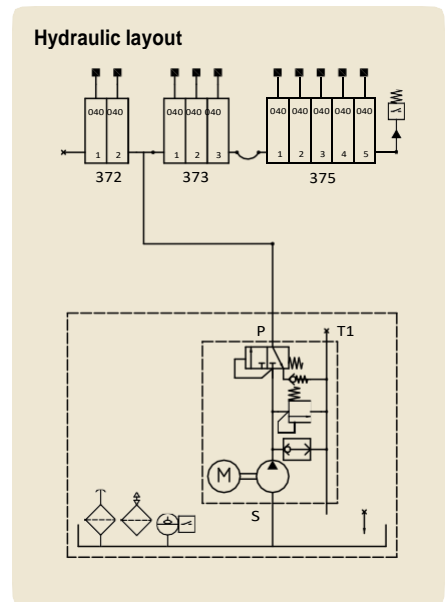
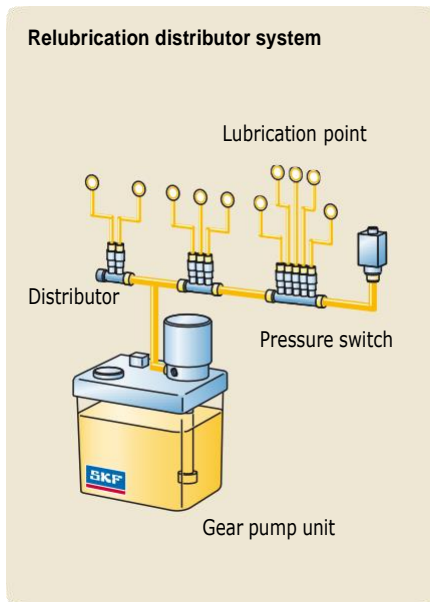
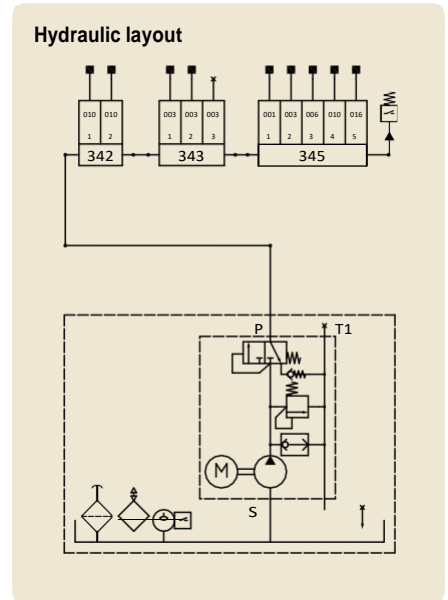
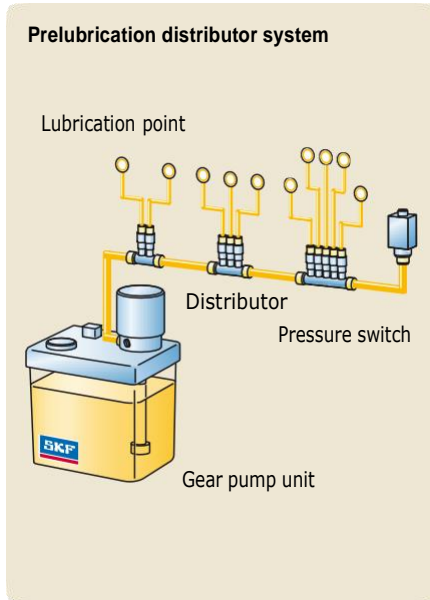

SKF MonoFlex system structure

Important notes

⚠ WARNING

Leaking lubricant is hazardous due to the risk of slipping and injury. Before using the equipment, fix any system where lubricant is leaking during assembly, operation, maintenance, and repair.

! Lubricants can contaminate soil and bodies of water. Lubricants must be used and disposed of properly. Observe the local regulations and laws regarding the disposal of lubricants.

When arranging the main lines and lubrication point lines, observe the following instructions so that the entire lubrication system functions smoothly.

The main line must be dimensioned in accordance with the maximum pressure losses occurring in the lubrication unit used and the displacement of that lubrication unit. If possible, the main line should rise upward from the lubrication unit and be ventable at the highest point on the lubrication line system.

Lubricant distributors at the end of the main line should be installed such that the outlets of the lubricant distributors point upwards. If the system configuration requires that the lubricant distributors be arranged below the main line, they should not be placed at the end of the main line (**Fig. 1**). If lubrication lines must lead to lubricant distributors that are lower than the main line, proceed as shown in **Figure 2**.

The pipelines, hoses, shutoff valves and directional control valves, fittings, etc. that will be used must be designed for the maximum operating pressure of the lubrication unit, the permissible temperatures, and the lubricants that will be delivered.

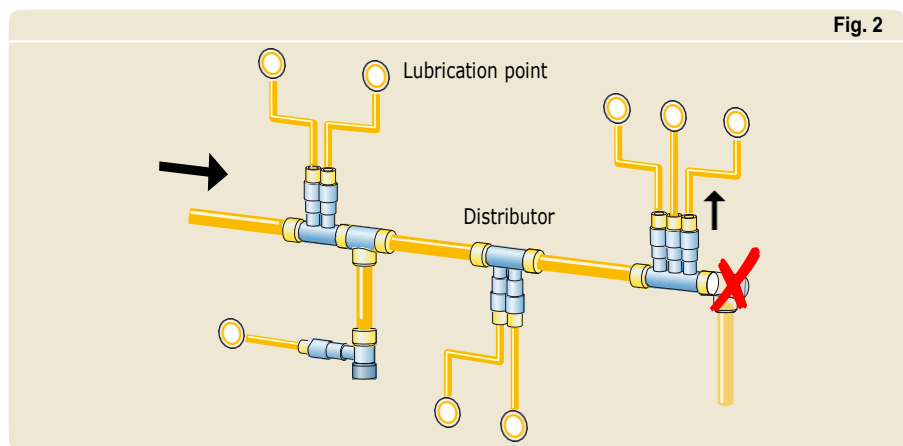
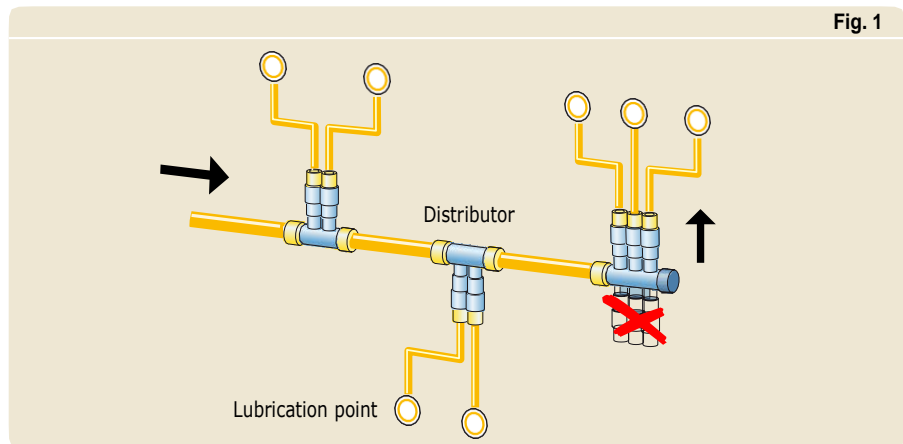

The lubrication line system also needs to be protected from excessive pressure by means of a pressure-limiting valve that is mounted separately or integrated into the lubrication unit. All components of the lubrication line system such as pipelines, hoses, shutoff valves and directional control valves, fittings, etc. must be carefully cleaned before assembly. No seals in the lubrication line system should protrude inward in a way that disrupts the flow of the lubricant and could allow contaminants to enter the lubrication line system. Lubrication lines should always be arranged so that air pockets cannot form anywhere. Avoid changes in the cross-section of the lubrication line from small to large cross-sections in the direction of flow of the lubricant. Vent plugs are recommended at appropriate places within the centralized lubrication system.

The flow of lubricant in the lubrication lines should not be impeded by the incorporation of sharp bends, angle valves, or flap valves. Unavoidable changes in the cross-section in lubrication lines must have smooth transitions. Sudden changes of direction should be avoided, if possible.

SKF MonoFlex connector systems

Overview

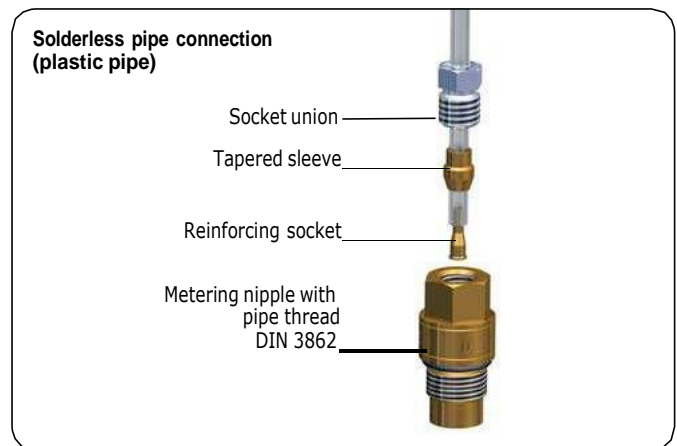
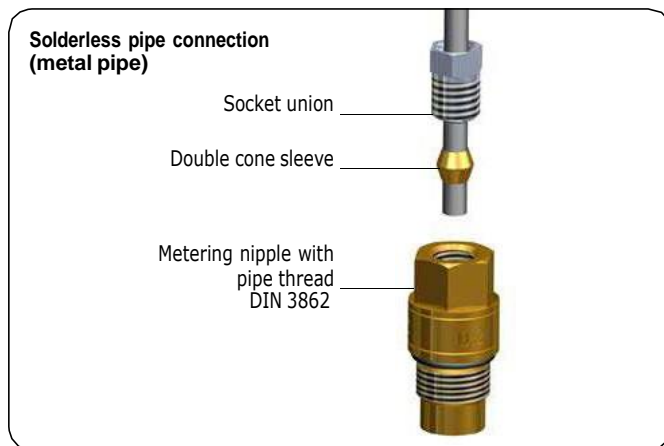
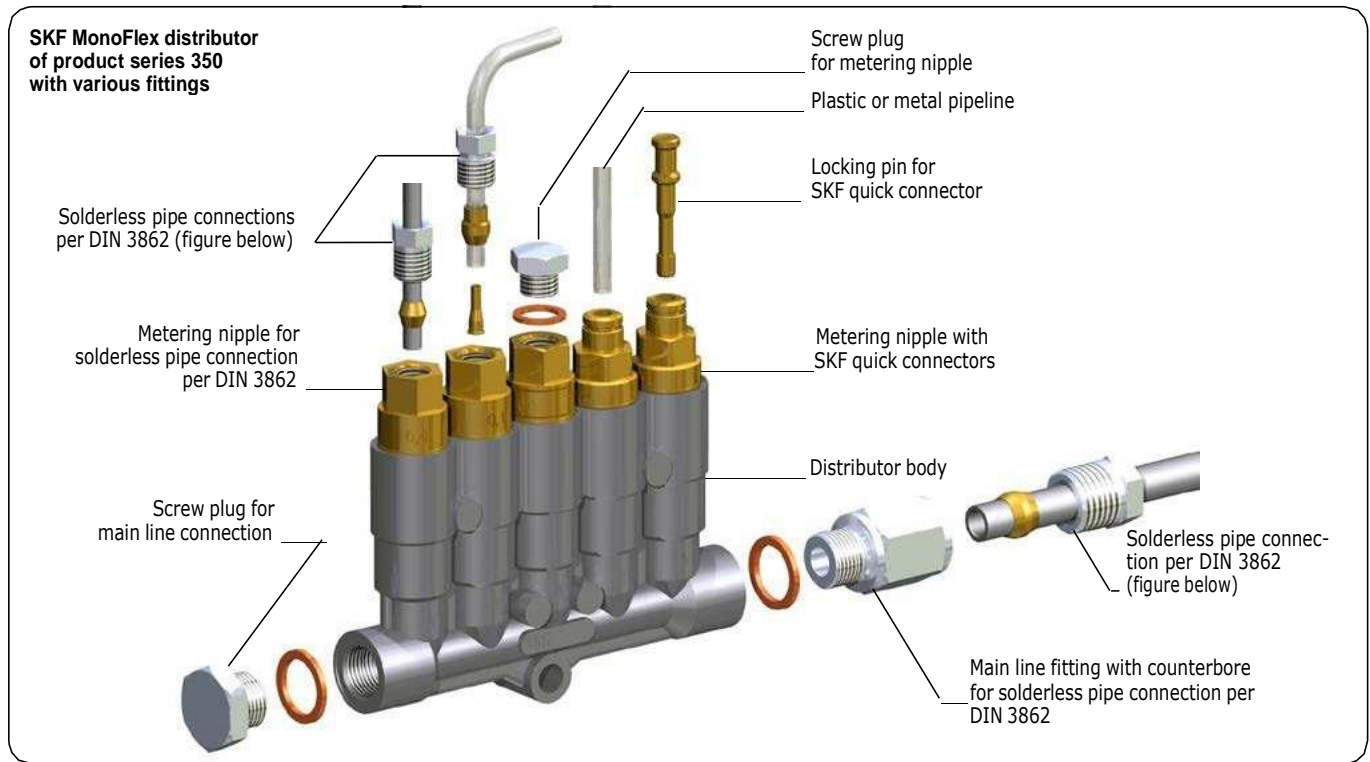

SKF Lubrication Systems offers a comprehensive product range of the most common fittings as well as pipelines made of metal or plastic pipe, or hose lines with metal pipe connectors for use in SKF MonoFlex single-line centralized lubrication systems.

For SKF MonoFlex single-line centralized lubrication systems with pressures up to 45 bar, SKF quick connectors or fittings for solderless pipe connections conforming to DIN 3862 can be used. For higher pressures, fittings with SKF quick connector systems (up to 300 bar) or cutting-sleeve screw unions (up to 250 bar) conforming to DIN 2353 are used.

Depending on the application, SKF MonoFlex single-line distributors can be equipped with different fittings on the connection for the main line and lubrication point lines. The overview in the figure above shows which fittings and pipelines SKF MonoFlex single-line distributors can be equipped with. Product series 350 is shown as an example. See the individual pages of the product series descriptions for details on the fittings available for the particular product series.

SKF MonoFlex connector systems

SKF quick connectors

The SKF quick connector system for plastic and metal pipelines allows reliable, fast, leak-free and inexpensive cable mounting in SKF MonoFlex single-line centralized lubrication systems. The system includes quick connectors for plastic and metal pipe diameters of 4, 6, and 8 mm in the common types of straight, elbow, or banjo fittings, as well as metering nipples for MonoFlex single-line distributors.

The SKF quick connector system is resistant to dirt and is suitable for industrial use as well as for year-round operation in all types of construction and road vehicles. For especially dirty ambient conditions, rubber protective caps are available for pipe diameters of 4 mm and 6 mm for SKF quick connectors.

The SKF quick connector system utilizes a 3 O-ring system, which makes it specially adapted to the high requirements and system pressures in SKF MonoFlex single-line centralized lubrication systems.

Inside, a collet with a locking claw acts on a claw groove in the metal pipe or directly onto the mounted plastic pipe. This keeps the mounted pipelines securely supported in the SKF quick connector even at pressures of 300 bar.

SKF quick connectors are suitable for constructing the entire lubrication system, from the lubrication unit to the single-line distributors, pressure switches, etc. to the lubrication points.

Rubber protective caps for SKF quick connectors

Line diameter [mm]	Order number
4	898-110-077
6	898-110-082

SKF quick connectors - Technical data

Lubricant	Oil, fluid grease, grease
Operating pressure	max. 300 bar
Temperature range	-40 to +80 °C
Seal material	NBR or FKM (FPM)

SKF pipe cutters

A pipe cutter can be used to cut the metal pipe to length in one step and to produce the exact geometric shape of the claw groove.

The pipe cutters available from SKF are listed below by pipe diameter.

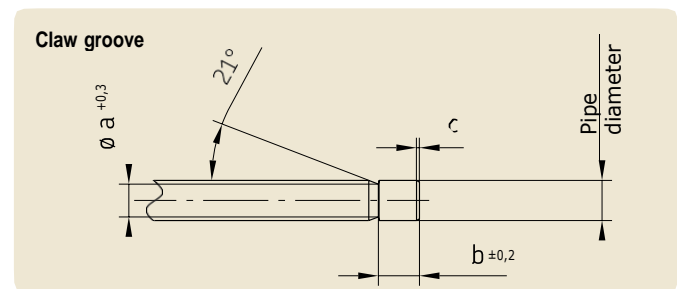
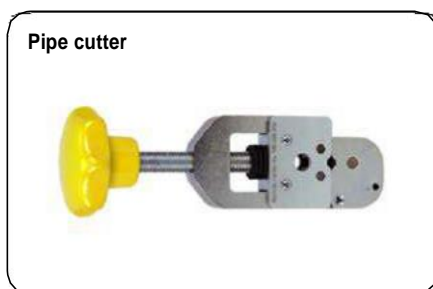

Ordering information for pipe cutter

Pipe diameter [mm]	4	6	8
Order number Pipe cutter	169-000-336	169-000-337	169-000-338
Order number Cutting ring	844-330-006	844-330-007	844-330-007

Claw groove dimensions

Pipe diameter [mm]	4	6	8
A	3,1	4,9	6,9
B	5,0	6,2	6,2
C	0,3 - 0,7	0,4 - 0,9	0,5 - 0,9

SKF MonoFlex connector systems

SKF quick connectors

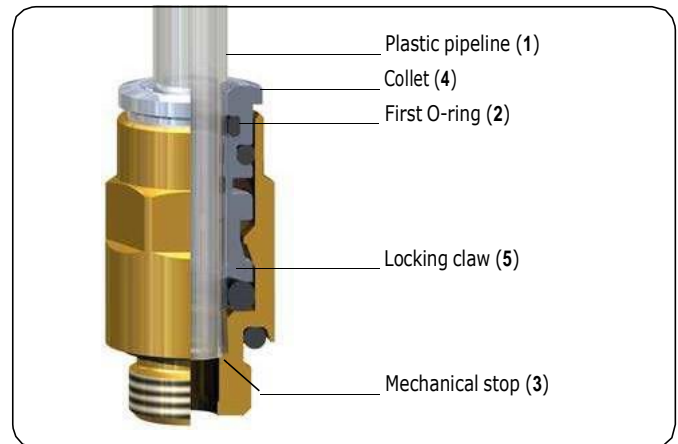
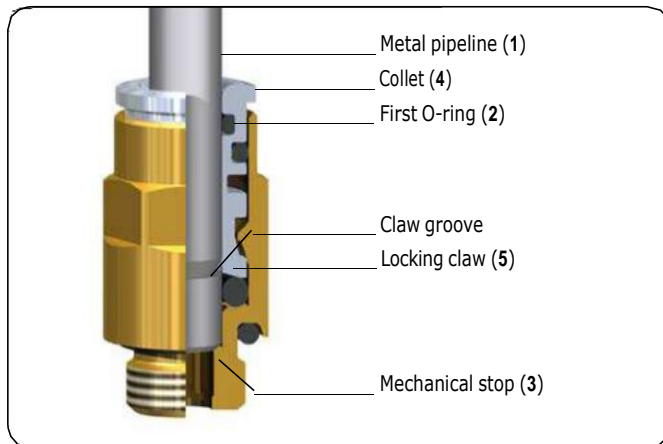

Metal pipeline assembly

The metal pipe can be assembled with or without a claw groove. The claw groove securely fastens the metal pipe in the quick connector, which prevents the metal pipe from slipping out of the SKF quick connector. The claw groove does not need to be used if an appropriate fastening material (e.g., mounting clips) is used to prevent the metal pipe from slipping out of the SKF quick connector.

Cut the metal pipe (1) to length using a special pipe cutter. Manually insert the metal pipe (1) fully into the collet (4) of the SKF quick connector until it clears the first O-ring (2) and the locking claw (5) of the collet (4) and reaches the mechanical stop (3). Clearing the first O-ring (2) and the locking claw (5) of the collet (4) is indicated by significant resistance.

If a claw groove is not used, fix the metal pipe using an appropriate fastening material (e.g., mounting clips) to prevent the metal pipe from slipping out of the SKF quick connector.

To disassemble the metal pipe (1), press the collet (4) inward into the SKF quick connector. The metal pipe (1) can now be pulled out of the collet (4) of the SKF quick connector.

Plastic pipeline assembly

The plastic pipe is mounted directly in the SKF quick connector. The locking claw of the collet secures the plastic pipe in the SKF quick connector, which prevents the pipe from accidentally slipping out. Cut the plastic pipe (1) straight to length using a suitable hose cutter. Manually insert the plastic pipe (1) fully into the collet (4) of the SKF quick connector until it clears the first O-ring (2) and the locking claw (5) of the collet (4) and reaches the mechanical stop (3). Clearing the first O-ring (2) and the locking claw (5) of the collet (4) is indicated by significant resistance.

To disassemble the plastic pipe (1), press the collet (4) inward into the SKF quick connector. To do this, press the plastic pipe (1) inward into the SKF quick connector, which releases the collet (4) from the plastic pipe (1). The plastic pipe (1) can now be pulled out of the collet (4) of the SKF quick connector.

Before reassembling, shorten the end of the plastic pipe by at least 7 mm so that the locking claw of the collet functions properly.

WARNING

High pressure hazard!
Depressurize system before disassembling
SKF quick connectors and screw unions.

SKF MonoFlex connector systems

Solderless pipe connections per DIN 3862

Solderless pipe connections from SKF that conform to DIN 3862 allow fast and easy assembly and disassembly of lubricant lines made of metal pipes and plastic. They are suitable for oil, fluid grease, and grease lubricants at pressures up to 45 bar and operating temperatures from $-25\text{ }^{\circ}\text{C}$ to $+80\text{ }^{\circ}\text{C}$.

Technical data

Lubricant	Oil, fluid grease, grease
Operating pressure	max. 45 bar
Temperature range	-25 to $+80\text{ }^{\circ}\text{C}$

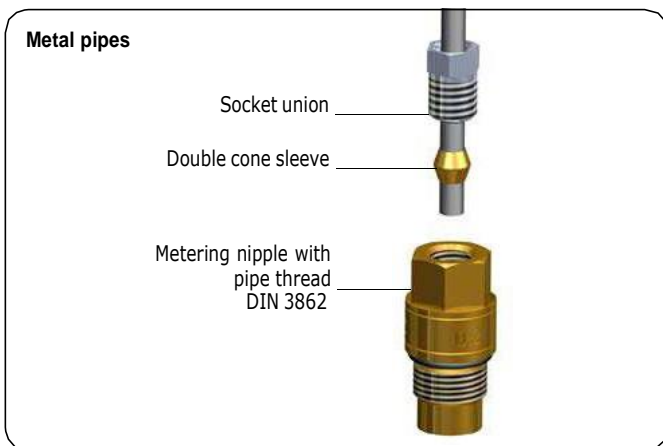

Initial assembly

Cut the metal pipe straight to length using a suitable tool, e.g., a pipe cutter. Push the socket union and the double cone sleeve onto the end of the metal pipe. Insert the end of the metal pipe into the depression until the stop and then tighten the socket union finger-tight. Then tighten the socket union by a max. of 1 1/2 revolutions.

Repeat assembly

After each time the screw union is loosened, the socket union must be firmly retightened (with the same force) as in the initial assembly.

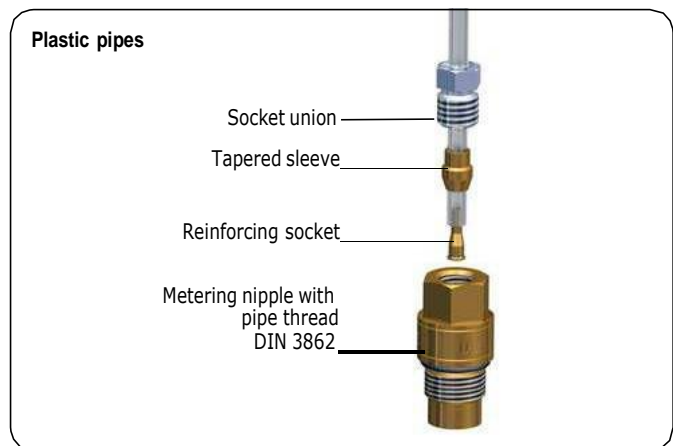

Initial assembly

Cut the plastic pipe straight to length using a suitable tool, e.g., a hose cutter. Insert the reinforcing socket into the end of the plastic pipe to stabilize the end of the plastic pipe being assembled. This prevents the plastic pipe from being constricted during assembly. Push the socket union and the tapered sleeve onto the end of the plastic pipe. Insert the end of the plastic pipe into the depression until the stop and then tighten the socket union finger-tight. Then tighten the socket union by a max. of 1 1/2 revolutions.

Repeat assembly

Each time after the screw union is loosened, the socket union must be firmly retightened (with the same force) as in the initial assembly.

WARNING

High pressure hazard!
Depressurize system before disassembling
SKF quick connectors and screw unions.

SKF MonoFlex connector systems

Pipe and hose lines



Depending on the application, SKF MonoFlex single-line centralized lubrication systems can be equipped with lubrication lines made of metal pipe, plastic pipe, and/or rubber hose lines. The choice of the internal diameter of the lubrication line (main, secondary, or lubrication point line) depends on the lubricant selected for feeding (oil, fluid grease, grease) and the pressure losses that

will be encountered. Larger expected pressure losses result from a smaller internal diameter of the lubrication line, a lower ambient temperature, and a higher oil/NLGI Grade of the fluid grease or grease. Further, the pressure losses are higher when the length of the lubrication line is increased.

External pipe diameters of 6, 8, 10 mm and larger are typically used for main lines and secondary lines; external pipe diameters of 2,5 and 4 mm are used for lubrication point lines.

Pipe and hose lines in comparison

Type	Operating temperature [°C]	Permissible operation pressure [bar] ¹⁾
Steel pipelines	-25 to +80	Up to 500
Plastic pipelines	-60 to +80	Up to 70
Low-pressure hose lines	-40 to +100	Up to 45
High-pressure hose lines	-40 to +100	Up to 225

¹⁾ The permissible operation pressure depends on the pipe diameter.

SKF MonoFlex connector systems

Steel pipes

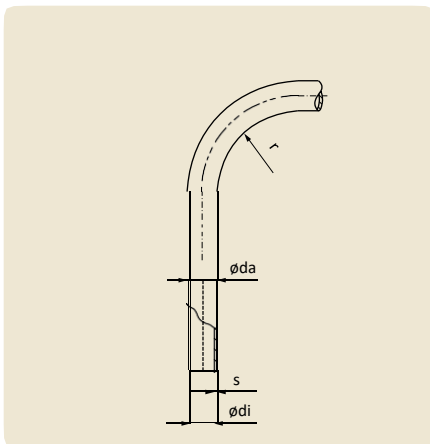

Steel pipes

Order number	ø da [mm]	s [mm]	ø di [mm]	Minimum bend radius r ¹⁾ [mm]	Permissible oper. pressure [bar]	Burst pressure [bar]
Steel pipe galvanized, Cr6-free						
WV-RO6x0.7 VERZI	6 ±0.05	0.7	4.6±0.11	12	320	850
WV-RO8x0.7 VERZI	8 ±0.05	0.7	6.6±0.11	19	230	675
WV-RO10x0.7 VERZI	10 ±0.05	0.7	8.6±0.13	27	180	550
Steel pipe acc. to EN10305-4, galvanized, Cr6-free						
982-120-041	4 ±0.05	0.7	2.6±0.10	12	368	952
982-120-040	4 ±0.08	1.0	2 ±0.15	12	500	1 360
982-120-060	6 ±0.08	1.0	4 ±0.12	18	372	963
982-120-080	8 ±0.08	1.0	6 ±0.10	24	288	723
982-120-100	10 ±0.08	1.0	8 ±0.08	30	248	612
982-120-120	12 ±0.08	1.5	9 ±0.10	36	303	765
982-120-150	15 ±0.08	1.5	12 ±0.08	45	248	612
982-120-180	18 ±0.08	1.5	15 ±0.08	54	209	510
Stainless steel pipe (material 1.4301/1.4306)						
D1127RO2.5x0.5+A46	2.5±0.03	0.5	1.5+0.05	7.5	386	1 664
DIN2462-RO4x1+A46	4 ±0.1	1	2 ±0.2	12	466	2 080
DIN2462-RO6x1+A46	6 ±0.1	1	4 ±0.2	18	347	1 473
DIN2462-RO8x1+A46	8 ±0.1	1	6 ±0.2	24	269	1 105
DIN2462-RO10x1+A46	10 ±0.1	1	8 ±0.2	30	231	936

Temperature range -25 to +80 °C

¹⁾ For cold bending with bending device or by hand with grooved disk.

²⁾ Dynamic load according to DIN 2413

Pipe bending device

ø steel pipeline [mm]	Order number
4, 6, 8, 10	248-803.20
12 (special grooved disk) ¹⁾	248-803.17
4 (Retro fitting set) ²⁾	248-803.16

¹⁾ To bend pipes with 12 mm diameter, the special grooved disk 248-803.17 must be ordered in addition to pipe bending device 248-803.20

²⁾ Retro fitting set with grooved disk for older pipe bending devices 248-803.20

Pipe bending device



SKF MonoFlex connector systems

Plastic pipes

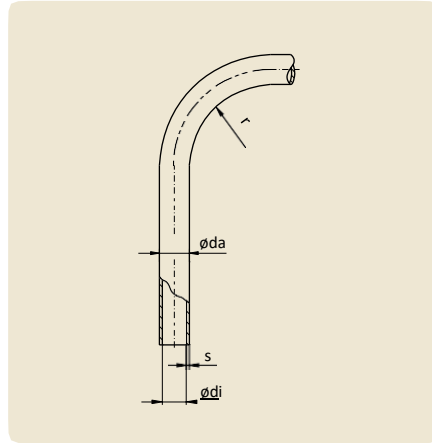

! Suitable bending devices can be used to achieve extremely small radii when bending plastic pipes. This requires that the pipe be heated to approx. 150 °C, with a maximum heating time of 20 seconds.

Plastic pipes WVN715, semirigid (unplasticized)

Order number ²⁾	ø da [mm]	S [mm]	ø di ^{+0,15} _{-0,0} [mm]	Minimum bend radius r [mm] freely bent	with device	Permiss. oper. pressure ¹⁾ at 23 °C [bar]	Burst pressure [bar]
WVN715-R02.5x0.5	2,5 ±0,1	0,5	1,5	25	9	66	198
WVN715-R04x0.85	4 ±0,1	0,85	2,3	38	14	72	216
WVN715-R06x1	6 ±0,1	1	4	63	21	53	159
WVN715-R06x1.25	6 ±0,1	1,25	3,5	63	21	70	210
WVN715-R08x1.25	8 ±0,1	1,25	5,5	76	28	49	147
WVN715-R010x1.5	10 ±0,15	1,5	7	89	35	47	141
WVN715-R012x1	12 ±0,15	1	10	110	45	24	72
WVN715-R012x1.5	12 ±0,15	1,5	9	110	45	38	141

¹⁾ The permissible operating pressure is lower at higher temperatures (→ the Pressure utilization factor table).

²⁾ If resistance to light-aging is desired, add the word "BLACK" in the order number (example = WVN715-R08x1,25x50M BLACK).

Plastic pipes WVN716, flexible (plasticized)

Order number ²⁾	ø da ±0,1 [mm]	s [mm]	ø di ^{+0,15} _{-0,0} [mm]	Minimum bend radius r [mm] freely bent	with device	Permiss. oper. pressure ¹⁾ at 23°C [bar]	Burst pressure [bar]
WVN716-R04x0.85	4	0,85	2,3	38	14	36	108
WVN716-R06x1.25	6	1,25	3,5	63	21	35	105
WVN716-R08x1.25	8	1,25	5,5	80	30	25	75

¹⁾ The permissible operating pressure is lower at higher temperatures (→ the Pressure utilization factor table).

²⁾ If resistance to light-aging is desired, add the word "BLACK" in the order number (example = WVN716-R08x1,25x50M BLACK).

Pressure utilization factor

Max. temperature up to [°C]	Pressure utilization factor [%]
30	83
40	72
50	64
60	57
70	52
80	47

Technical data

WVN715	PA 12 H Polyamide, semirigid, unplasticized as per DIN 73378, stabilized against heat and aging	PA 12 HL (black) Polyamide, semirigid, unplasticized as per DIN 73378, stabilized against light, heat, and aging
WVN716	PA 12 PH Polyamide, flexible, plasticized as per DIN 73378, stabilized against heat and aging	PA 12 PHL (black) Polyamide, flexible, plasticized as per DIN 73378, stabilized against light, heat, and aging
Temperature range	-60 to +80 °C	-60 to +80 °C

SKF MonoFlex connector systems

Low-pressure hose lines for main lines and secondary lines

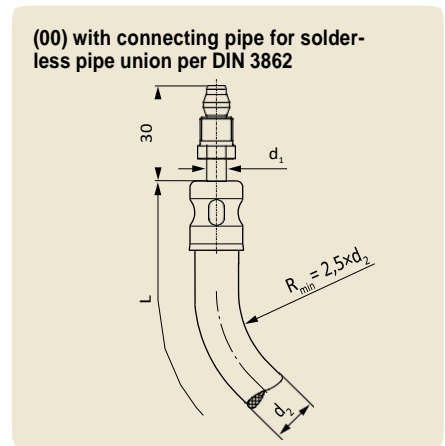
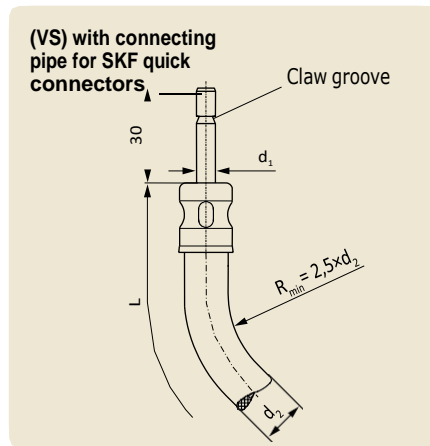
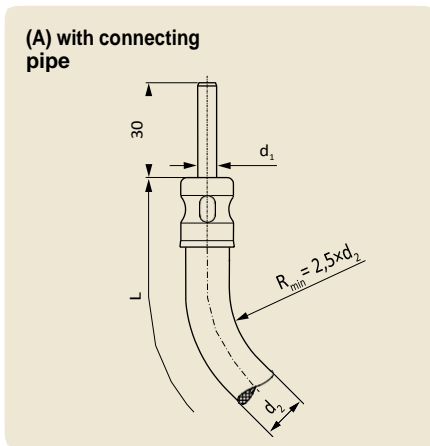

Ordering information

Permissible oper. pressure [bar]	Operating temperature [°C]		d ₁ ∅ connecting pipe [mm]	d ₂ ∅ hose outside [mm]	∅ hose internal [mm]	Length L* ±5 [mm]	Order number		
	min	max					Design A	Design VS	Design 00
45	-40	100	4	11	3,2	180	714-180	714-180-VS	714-180-K
						260	714-260	714-260-VS	714-260-K
						300	714-300	714-300-VS	714-300-K
						400	714-400	714-400-VS	714-400-K
						500	714-500	714-500-VS	714-500-K
						600	714-600	714-600-VS	714-600-K
	-40	100	6	13	4,5	180	716-180	716-180-VS	716-180-K
						260	716-260	716-260-VS	716-260-K
						300	716-300	716-300-VS	716-300-K
						400	716-400	716-400-VS	716-400-K
						500	716-500	716-500-VS	716-500-K
						600	716-600	716-600-VS	716-600-K
	-40	100	8	15	6,5	180	718-180	718-180-VS	718-180-K
						260	718-260	718-260-VS	718-260-K
						300	718-300	718-300-VS	718-300-K
						400	718-400	718-400-VS	718-400-K
						500	718-500	718-500-VS	718-500-K
						600	718-600	718-600-VS	718-600-K

* Additional lengths on request



Material

Hose Chloroprene - mineral oil-resistant inner liner, two braided rayon inserts, outer liner partially oil-resistant, resistant to sun-cracking, and ozone-resistant

Connecting pipe ends Steel pipe, galvanized, Cr6-free

Volume increase

At pressure [bar]	Volume increase [cm ³ /m]
80	2,5
	3,6
	4,4

SKF MonoFlex connector systems

Low-pressure hose lines with cover braid for main lines and secondary lines

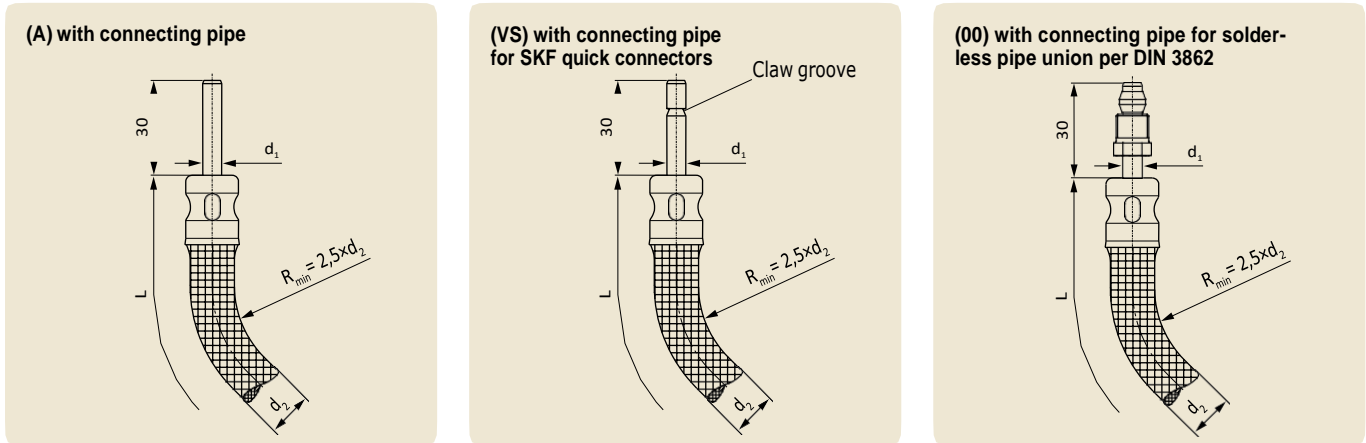

Ordering information

Permissible oper. pressure [bar]	Operating temperature [°C]		d ₁ ∅ connecting pipe [mm]	d ₂ ∅ hose outside [mm]	∅ hose internal [mm]	Length L* ±5 [mm]	Order number		
	min	max					Design A	Design VS	Design 00
45	-40	100	4	12	3,2	180	714-180-M	714-180-M-VS	714-180-M-K
						260	714-260-M	714-260-M-VS	714-260-M-K
						300	714-300-M	714-300-M-VS	714-300-M-K
						400	714-400-M	714-400-M-VS	714-400-M-K
						500	714-500-M	714-500-M-VS	714-500-M-K
						600	714-600-M	714-600-M-VS	714-600-M-K
	-40	100	6	14	4,5	180	716-180-M	716-180-M-VS	716-180-M-K
						260	716-260-M	716-260-M-VS	716-260-M-K
						300	716-300-M	716-300-M-VS	716-300-M-K
						400	716-400-M	716-400-M-VS	716-400-M-K
						500	716-500-M	716-500-M-VS	716-500-M-K
						600	716-600-M	716-600-M-VS	716-600-M-K
	-40	100	8	16	6,5	180	718-180-M	718-180-M-VS	718-180-M-K
						260	718-260-M	718-260-M-VS	718-260-M-K
						300	718-300-M	718-300-M-VS	718-300-M-K
						400	718-400-M	718-400-M-VS	718-400-M-K
						500	718-500-M	718-500-M-VS	718-500-M-K
						600	718-600-M	718-600-M-VS	718-600-M-K

* Additional lengths on request



Material

Hose	Chloroprene - mineral oil-resistant inner liner, two braided rayon inserts, outer liner partially oil-resistant, resistant to sun-cracking, and ozone-resistant
Metal braid	Steel wire, galvanized, Cr6-free
Connecting pipe ends	Steel pipe, galvanized, Cr6-free

Volume increase

At pressure [bar]	Volume increase [cm ³ /m]
80	2,5
	3,6
	4,4

PUBLS/P2 11213 EN · 1-5001-EN

SKF MonoFlex connector systems

Low-pressure hose lines for lubrication point lines

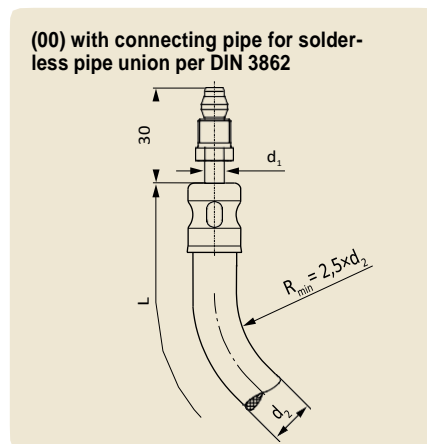
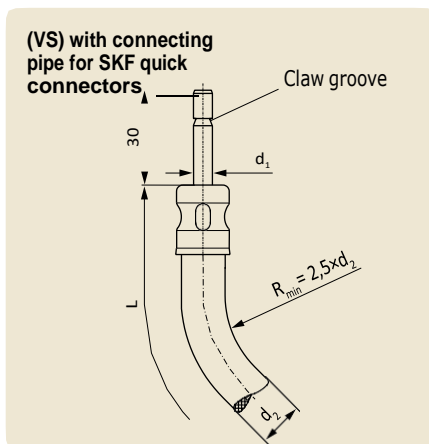
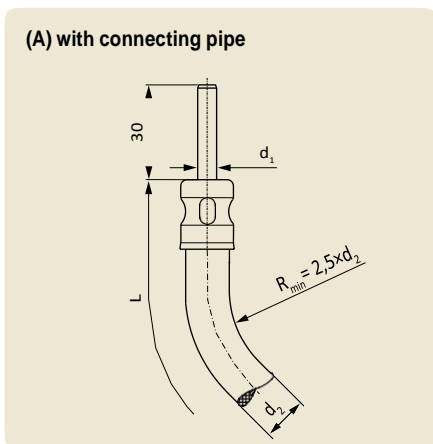

Ordering information

Permissible oper. pressure [bar]	Operating temperature [°C]		d ₁ ∅ connecting pipe [mm]	d ₂ ∅ hose outside [mm]	∅ hose internal [mm]	Length L* ±5 [mm]	Order number		
	min	max					Design A	Design VS	Design 00
15	-40	70	4	8,8	3,2	180	734-180	734-180-VS	734-180-K
						260	734-260	734-260-VS	734-260-K
						300	734-300	734-300-VS	734-300-K
						400	734-400	734-400-VS	734-400-K
						500	734-500	734-500-VS	734-500-K
						600	734-600	734-600-VS	734-600-K

* Additional lengths on request



Material

Hose Chloroprene - mineral oil-resistant inner liner, a braided rayon insert, outer liner partially oil-resistant, resistant to sun-cracking, and ozone-resistant

Connecting pipe ends Steel pipe, galvanized, Cr6-free

SKF MonoFlex connector systems

High-pressure hose lines

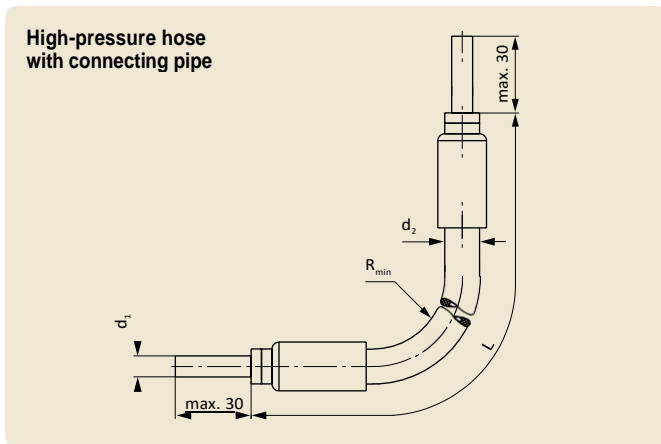

Ordering information

Permissible oper. pressure [bar]	Operating temperature [°C]		d ₁ ø connecting pipe [mm]	Minimum bend radius R _{min} [mm]	d ₂ ø hose outside [mm]	ø hose internal [mm]	Length L* ±5 [mm]	Order number
	min	max						
175	-40	100	10	44	14,5	7,9	180	SLH10-180
							250	SLH10-250
							300	SLH10-300
							400	SLH10-400
							500	SLH10-500
							600	SLH10-600
							700	SLH10-700
							800	SLH10-800
210	-40	100	8	32	13	6,3	180	SLH8-180
							250	SLH8-250
							300	SLH8-300
							400	SLH8-400
							500	SLH8-500
							600	SLH8-600
							700	SLH8-700
							800	SLH8-800
225	-40	100	6	19	11	4,8	180	SLH6-180
							250	SLH6-250
							300	SLH6-300
							400	SLH6-400
							500	SLH6-500
							600	SLH6-600
							700	SLH6-700
							800	SLH6-800

*Additional lengths on request



Material

Inner hose	Polyester elastomers
Reinforcement	High-tensile synthetic fiber braid
Outer hose	Polyurethane
Connecting pipe ends	Steel pipe, galvanized, Cr6-free

SKF MonoFlex prelubrication distributors of product series AB

General

SKF MonoFlex single-line distributors of product series AB are single-port prelubrication distributors for MonoFlex single-line centralized lubrication systems for oil and fluid grease lubrication. These single-line distributors are designed for installation in manifolds. The combination of these single-line distributors with 1- to 6-port manifolds provides flexible options for designing the lubrication system on the machine/system requiring lubrication. Manifolds customized for product series AB are available in aluminum and stainless steel designs.

The available metered quantities are in the range from 0,01 to 0,60 cm³. The metering elements have a mark indicating the metered quantity. The lubrication point line is connected using solderless pipe unions (DIN 3862). Lubrication point lines can be connected that are made of metal pipe, plastic pipe, or hose lines with metal pipe connectors. The diameter of the lubrication point line that will be connected is 4 mm. The metering cannot be modified later.

The components made of elastomers inside the single-line distributors are made of FKM (FPM).

The distributor body is available in steel (galvanized, Cr6-free) and stainless steel designs. Depending on the design, a copper sealing ring or a stainless steel ring is used to seal the internal thread for mounting the single-port single-line distributor in a manifold.

See the following pages for further information on product series AB. Details on accessories for SKF MonoFlex single-line centralized lubrication systems are part of this catalog.

AB distributor



Manifold VL



! The configurator on the following page does **not** allow specification of manifolds and distributors in a single order code. The manifolds are listed under Accessories and must be ordered separately.

Technical data

Product series AB

Lubricant	Metering [cm ³]	Operating pressure [bar]		Relief pressure [bar]	Operating temperature [°C]
		min.	max.		
Mineral and synthetic oil 20 to 1 000 mm ² /s; compatible with FKM (FPM), brass, steel	0,01 – 0,60	18	50	Max. 3	0 – 80
Fluid grease of NLGI Grade 000, 00 compatible with FKM (FPM), brass, steel	0,01 – 0,60	18	50	Max. 3	0 – 80

Tightening torque for assembly

distributor	Gasket	Tightening torques [Nm]
AB	Copper ring	10
AB	Stainless steel ring	10

SKF MonoFlex prelubrication distributors of product series AB

Configurator

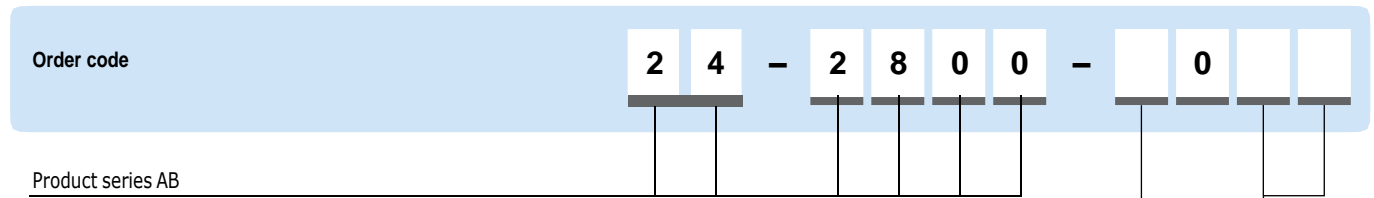

Design and metered quantity

Design code	5	9
Lubricant	Oil / Fluid grease	Oil / Fluid grease
Secondary line ø [mm]	4	4
Distributor body material	Galvanized steel	Stainless steel
Threaded seal material	Copper ring	Stainless steel ring
Metered quantity code [cm ³]	01	01
	02	02
	03	03
	05	05
	10	10
	20	20
	40	40
	60	60

Order example

24-2800-9010

- Single-port single-line distributor for oil and fluid grease
- Stainless steel
- Metering 0,1 cm³
- Seal: Stainless steel ring

PUBLS/P2 11213 EN · 1-5001-EN

SKF MonoFlex prelubrication distributors of product series AB

Dimensions

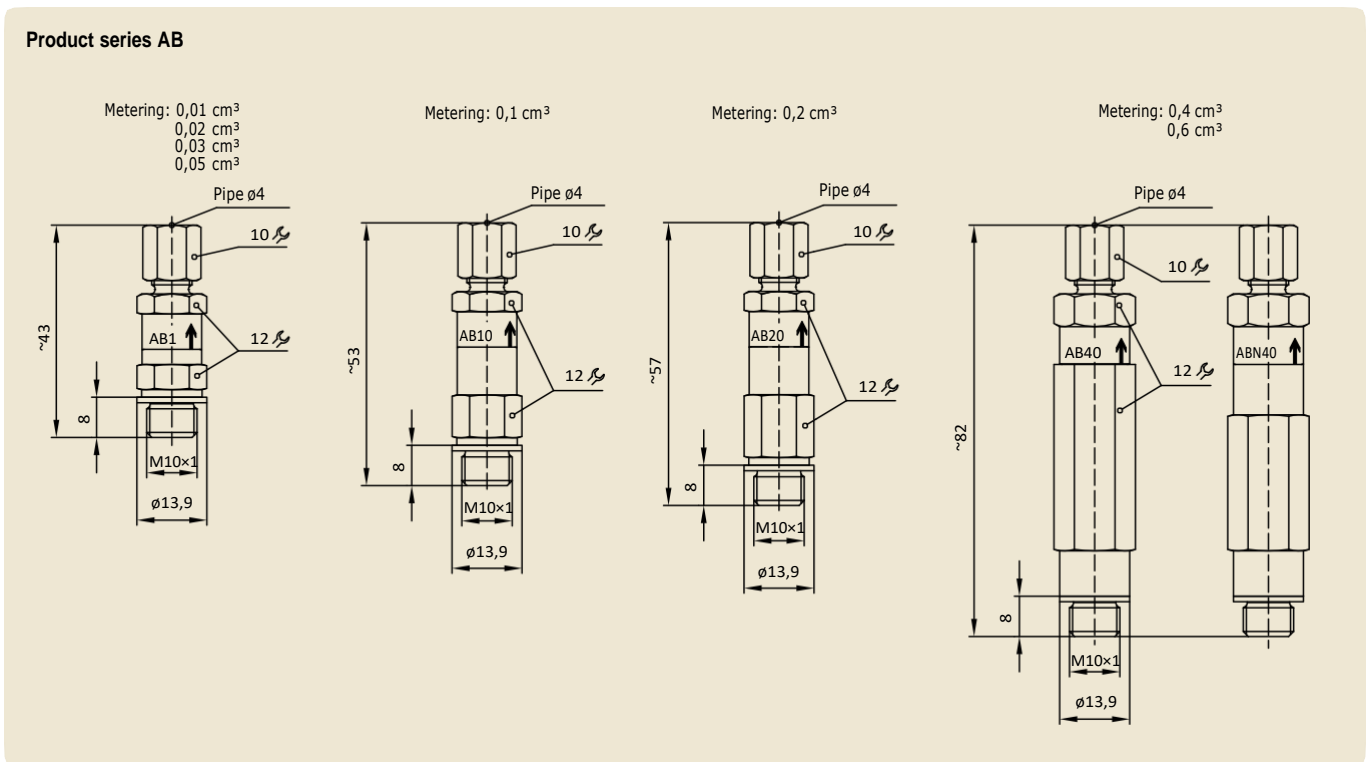

Mark

Metering [cm ³]	Design mark	
	Galvanized steel	Stainless steel
0,01	AB1	ABN1
0,02	AB2	ABN2
0,03	AB3	ABN3
0,05	AB5	ABN5
0,10	AB10	ABN10
0,20	AB20	ABN20
0,40	AB40	ABN40
0,60	AB60	ABN60

SKF MonoFlex prelubrication distributors of product series AB

Manifolds for product series AB

Order code

V L -

Product series

Ports

01 = 1 screw-in point 04 = 4 screw-in points
 02 = 2 screw-in points 05 = 5 screw-in points
 03 = 3 screw-in points 06 = 6 screw-in points
 (other ports available on request)

Design of distributor pipe thread

E = Narrow profile, M10x1 with counterbore for flat washer
 G = Normal profile, M10x1 with counterbore for flat washer

Material

A = Aluminum
 E = Stainless steel (1.4305) (can only be selected for normal profile)

Design of main line connection

G1 = G1/8 per DIN 3852-2, Form X, narrow
 G2 = G1/4 per DIN 3852-2, Form X, narrow
 M3 = M10x1 with counterbore for solderless pipe union per DIN 3862
 M4 = M14x1.5 with counterbore for solderless pipe union per DIN 3862
 (can only be selected for normal profile)

Order example

VL-02GAM3

- Product series VL
- 2 ports
- Normal profile made of aluminum
- M10x1 internal thread with counterbore for flat washer
- M10x1 main line connection with counterbore for solderless pipe union per DIN 3862

Dimensions

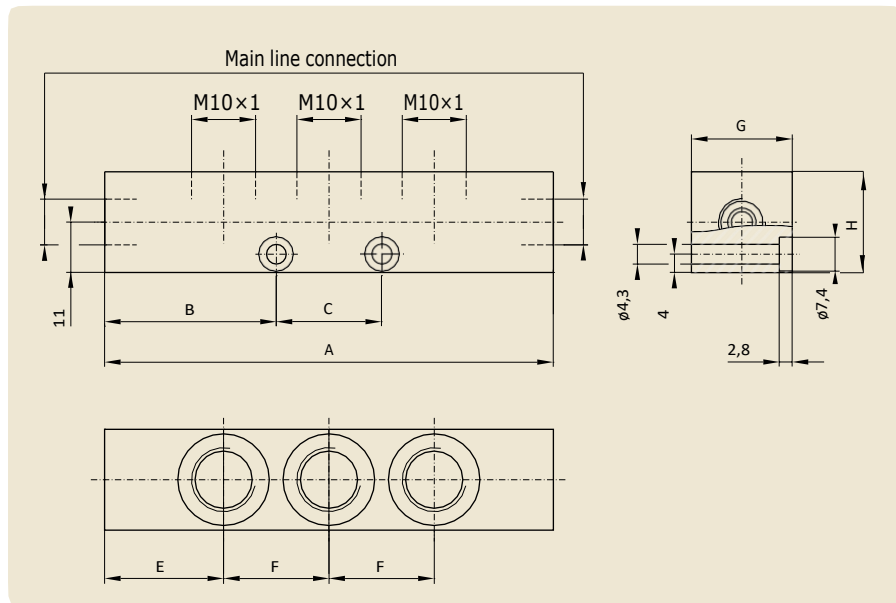

Normal profile G
Main line connection M10x1

Dimensions [mm]

Ports	A	B	C	E	F	G	H
1	40	20	-	20	-	22	22
2	57	28,5	-	20	1x17	22	22
3	74	28,5	17	20	2x17	22	22
4	91	28,5	34	20	3x17	22	22
5	108	28,5	51	20	4x17	22	22
6	125	28,5	68	20	5x17	22	22

Normal profile G
Main line connection M14x1.5

Dimensions [mm]

Ports	A	B	C	E	F	G	H
1	52	26	-	26	-	22	22
2	69	34,5	-	26	1x17	22	22
3	86	34,5	17	26	2x17	22	22
4	103	34,5	34	26	3x17	22	22
5	128	34,5	51	26	4x17	22	22
6	137	34,5	68	26	5x17	22	22

Narrow profile E
Main line connection M10x1

Dimensions [mm]

Ports	A	B	C	E	F	G	H
1	41	20,5	-	20,5	-	18	20
2	58	29	-	20,5	1x17	18	20
3	75	37,5	-	20,5	2x17	18	20
4	92	29	34	20,5	3x17	18	20
5	109	29	51	20,5	4x17	18	20
6	126	29	68	20,5	5x17	18	20

Normal profile G
Main line connection G1/8

Dimensions [mm]

Ports	A	B	C	E	F	G	H
1	34	17	-	17	-	22	22
2	51	25,5	-	17	1x17	22	22
3	68	25,5	17	17	2x17	22	22
4	85	25,5	34	17	3x17	22	22
5	102	25,5	51	17	4x17	22	22
6	119	25,5	68	17	5x17	22	22

Normal profile G
Main line connection G1/4

Dimensions [mm]

Ports	A	B	C	E	F	G	H
1	46	23	-	23	-	22	22
2	63	31,5	-	23	1x17	22	22
3	80	31,5	17	23	2x17	22	22
4	97	31,5	34	23	3x17	22	22
5	114	31,5	51	23	4x17	22	22
6	131	31,5	68	23	5x17	22	22

PUBLS/P2 11213 EN · 1-5001-EN

SKF MonoFlex prelubrication distributors of product series 341

General

SKF MonoFlex single-line distributors of product series 341 are single-port prelubrication distributors for SKF MonoFlex single-line centralized lubrication systems for oil and fluid grease lubrication. These single-line distributors are designed for installation in manifolds. The combination of these single-line distributors with 1- to 6-port manifolds provides flexible options for designing the lubrication system on the machine/system requiring lubrication. Manifolds customized for product series 341 are available in aluminum and stainless steel designs.

The available metered quantities are in a range from 0,01 – 0,16 cm³. The metering nipples have a mark indicating the metered quantity. To better distinguish between different designs, metering nipples for oil are made of brass and metering nipples for fluid grease are made of nickel-plated brass. Metering nipples made of stainless steel are untreated. The lubrication point line can be connected to the metering nipple using SKF quick connectors or solderless pipe connections (DIN 3862) depending on the selected metered quantity. Lubrication point lines can be connected that are made of metal pipe, plastic pipe, or hose lines with metal pipe connectors. The diameter of the lubrication point line that will be connected can be either 2,5 mm or 4 mm.

The lubrication point outlet can be closed using a locking pin (SKF quick connector) or a screw plug with a flat washer (solderless pipe connection). Metering nipples for metered quantities above 0,03 cm³ can be replaced later to yield different metered quantities.

The components made of elastomers in the interior of the single-line distributors are made of NBR or FKM (FPM) depending on the design. The distributor body is available in aluminum and stainless steel designs. The seal of the internal thread for mounting the single-port single-line distributor in a manifold is available in soft-sealing (with O-ring) and flat washer designs.

See the following pages for further information on product series 341. Details on manifolds and accessories for SKF MonoFlex single-line centralized lubrication systems are part of this catalog.

 The configurator on the following page **does not** allow specification of manifolds and distributors in a single order code. The manifolds are listed under Accessories and must be ordered separately.

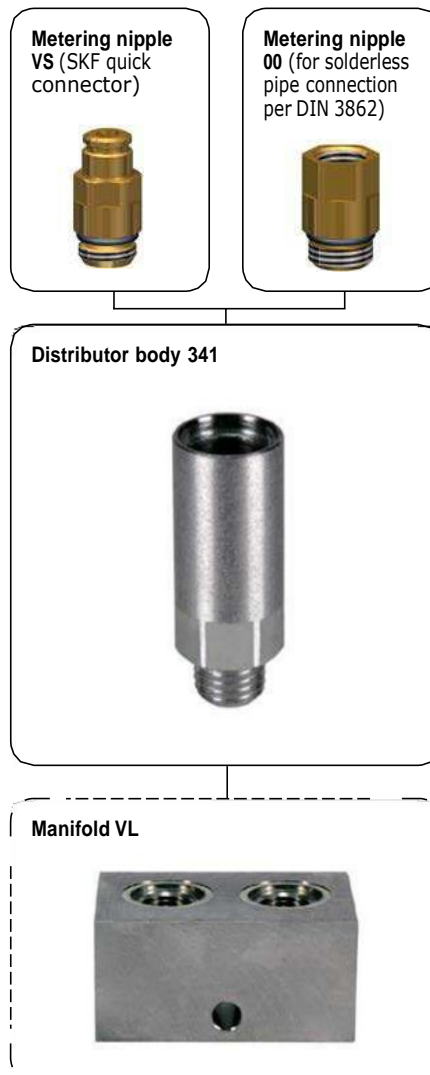

Technical data

Product series 341

Lubricant	Metered quantity [cm ³]	Metering nipple	Operating pressure [bar]		Relief pressure [bar]	Operating temperature [°C]
			min.	max.		
Mineral and synthetic oil 20 – 2 000 mm ² /s; compatible with steel, FKM (FPM)/NBR, brass	0,01 – 0,02	00	12	45	max. 3	0 – 80
		VS	12	80	max. 3	0 – 80
	0,03 – 0,16	00	6	45	≤ 1	0 – 80
		VS	6	80	≤ 1	0 – 80
Fluid grease of NLGI Grade 000, 00; compatible with steel, FKM (FPM)/NBR, brass	0,03 – 0,10	00	12	45	max. 3	0 – 80
		VS	12	80	max. 3	0 – 80

Tightening torque for assembly

Distributor	Seal	Tightening torques [Nm]
341-xxx-x0000-00	O-ring	2,5
341-xxx-x0000-00	Flat washer	6

SKF MonoFlex prelubrication distributors of product series 341

Configurator

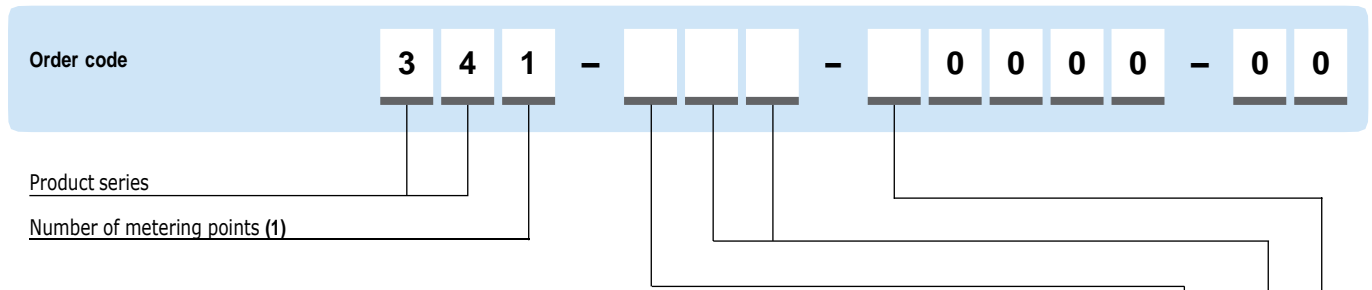

Design and metered quantity	2	4	8	5	9	1	7	6
Design code	2	4	8	5	9	1	7	6
Lubricant	Oil	Oil	Oil	Fluid grease	Fluid grease	Oil	Fluid grease	Oil
∅ lubrication point line [mm]	2,5	4	4	4	4	4	4	4
Distributor body material	Aluminium	Aluminium	Aluminium	Aluminium	Aluminium	Aluminium	Aluminium	Stainless steel (1.4305)
Metering nipple material	Brass	Brass	Brass	Brass nickel-plated	Brass nickel-plated	Brass	Brass nickel-plated	Stainless steel (1.4305)
Elastomer material	NBR	NBR	FKM (FPM)	NBR	FKM (FPM)	NBR	NBR	FKM (FPM)
Threaded seal material	Flat washer ²⁾	Flat washer ²⁾	Flat washer ²⁾	Flat washer ²⁾	Flat washer ²⁾	O-ring ³⁾	O-ring ³⁾	O-ring ³⁾
Lubrication point line connection	00	VS 00	VS 00	VS 00	00	VS 00	VS 00	00
Metered quantity code	1	1 1	1 1	1 1	-	1 1	-	1
Metered quantity [cm ³]	0,01 ¹⁾	0,02 ¹⁾	0,03	0,06	0,10	0,16	0,01 ¹⁾	0,02 ¹⁾
	1	2	2	2	2	2	2	2
	3	3	3	3	3	3	3	3
	4	4	4	4	4	4	4	4
	5	5	5	5	-	5	-	5

Design of lubrication point line connection (vs = SKF quick connectors, 00 = solderless pipe connection)

Metered quantity code

¹⁾ Subsequent modification of the metered quantity is not technically possible.
²⁾ Flat washer must be ordered separately. Order number: DIN7603-A8x11.5-CU
³⁾ O-ring is part of the shipment

Order example

341-100-30000-00

- Single-port single-line distributor for oil
- NBR design
- Lubrication point line connection per DIN 3862 for pipe ∅ 4 mm
- Metered quantity 0,06 cm³
- O-ring seal on internal thread

PUBLS/P2 11213 EN · 1-5001-EN

SKF MonoFlex prelubrication distributors of product series 341

Dimensions

Product series 341 + SKF quick connectors (VS)

Product series 341 + solderless pipe connection (00)

Mark on metering nipple

Metered quantity [cm ³]	Mark
0,01	1
0,02	2
0,03	3
0,06	6
0,10	10
0,16	16

Accessories

Order numbers for metering nipples for oil (replaceable)

ø lubrication point line [mm]	Metering nipple material	Elastomer material	Metering nipple	Metered quantity [cm ³]			
				0,03	0,06	0,10	0,16
2,5	Brass	NBR	00	995-994-003	995-994-006	995-994-010	995-994-016
4	Brass	NBR	VS	995-994-103-VS	995-994-106-VS	995-994-110-VS	995-994-116-VS
4	Brass	NBR	00	995-994-103	995-994-106	995-994-110	995-994-116
4	Brass	FKM (FPM)	VS	341-453-S8-VS	341-456-S8-VS	341-460-S8-VS	341-466-S8-VS
4	Brass	FKM (FPM)	00	341-453-K-S8	341-456-K-S8	341-460-K-S8	341-466-K-S8
4	Stainless steel (1.4305)	FKM (FPM)	00	341-453-K-S81	341-456-K-S81	341-460-K-S81	341-466-K-S81

Order numbers for metering nipples for fluid grease (replaceable)

ø lubrication point line [mm]	Metering nipple material	Elastomer material	Metering nipple	Metered quantity [cm ³]		
				0,03	0,06	0,10
4	Brass, nickel-plated	NBR	VS	341-853-VS	341-856-VS	341-860-VS
4	Brass, nickel-plated	NBR	00	341-853-K	341-856-K	341-860-K
4	Brass, nickel-plated	FKM (FPM)	00	341-853-K-S8	341-856-K-S8	341-860-K-S8

Fittings for metering nipples

Description	ø lubrication point line [mm]	Pipe thread	Order number A	B	C
Screw plug with flat washer for solderless pipe connection	2,5	M6x0,75	402-011.U1	-	-
	4	M8x1	404-011.U1	-	-
Locking pin (A) for SKF quick connectors	4	-	450-204-002	-	-
Solderless pipe connection for metal pipeline* consisting of socket union (A) and double cone sleeve (B)	2,5	M6x0,75	402-002	402-001	-
	4	M8x1	404-002	404-001	-
Solderless pipe connection for plastic pipe* consisting of socket union (A), reinforcing socket (B), and tapered sleeve (C)	2,5	M6x0,75	402-612	402-603	402-611
	4	M8x1	404-612	404-603	404-611

* For more information, → page 14.

SKF MonoFlex prelubrication distributors of product series 341

Manifolds for product series 341

Order code

V L -

Product series

Number of ports
01 = 1 screw-in point **04** = 4 screw-in points
02 = 2 screw-in points **05** = 5 screw-in points
03 = 3 screw-in points **06** = 6 screw-in points
 (other numbers of ports available on request)

Design of distributor pipe thread
A = Normal profile, M8x1 with counterbore for O-ring
D = Small profile, M8x1 with counterbore for flat washer
 (can only be selected for main line connection **M3**)
F = Normal profile, M8x1 with counterbore for flat washer

Material
A = Aluminum
E = Stainless steel (1.4305) (can only be selected for normal profile)

Design of main line connection
G1 = G1/8 per DIN 3852-2, Form X, schmal
G2 = G1/4 per DIN 3852-2, Form X, schmal
M3 = M10x1 with counterbore for solderless pipe connection per DIN 3862 (→ page 14)
M4 = M14x1,5 with counterbore for solderless pipe connection per DIN 3862 (→ page 14)
 (can only be selected for normal profile)

Order example

VL-02AAM3

- Product series VL
- 2 ports
- Normal profile made of aluminum
- M8x1 internal thread with counterbore for O-ring
- M10x1 main line connection with counterbore for solderless pipe connection per DIN 3862

Dimensions

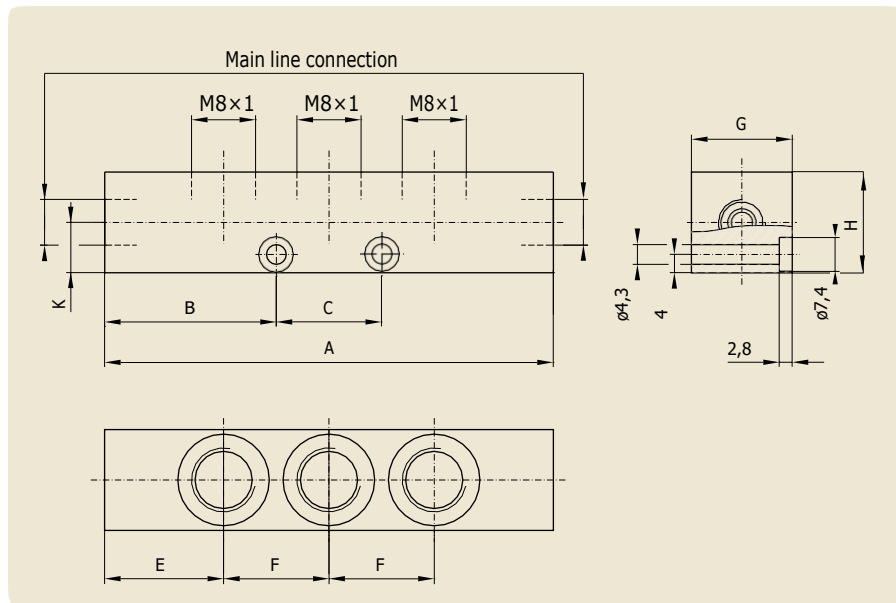

Normal profile A/F
Main line connection M10x1
 Number Dimensions [mm]
 of ports A B C E F G H K

1	40	20	-	20	-	22	22	11
2	55	27.5	-	20	1x15	22	22	11
3	70	27.5	15	20	2x15	22	22	11
4	85	27.5	30	20	3x15	22	22	11
5	100	27.5	45	20	4x15	22	22	11
6	115	27.5	60	20	5x15	22	22	11

Normal profile A/F
Main line connection M14x1.5
 Number Dimensions [mm]
 of ports A B C E F G H K

1	48	24	-	24	-	22	22	11
2	63	31.5	-	24	1x15	22	22	11
3	78	31.5	15	24	2x15	22	22	11
4	93	31.5	30	24	3x15	22	22	11
5	108	31.5	45	24	4x15	22	22	11
6	123	31.5	60	24	5x15	22	22	11

Small profile D
Main line connection M10x1
 Number Dimensions [mm]
 of ports A B C E F G H K

1	39	19.5	-	20.5	-	13	17	10.5
2	52	26	-	20.5	1x13	13	17	10.5
3	65	32.5	-	20.5	2x13	13	17	10.5
4	78	39	-	20.5	3x13	13	17	10.5
5	91	45.5	-	20.5	4x13	13	17	10.5
6	104	26	52	20.5	5x13	13	17	10.5

Normal profile A/F
Main line connection G1/8
 Number Dimensions [mm]
 of ports A B C E F G H K

1	34	17	-	17	-	22	22	11
2	49	24.5	-	17	-	22	22	11
3	64	24.5	15	17	2x15	22	22	11
4	79	24.5	30	17	3x15	22	22	11
5	94	24.5	45	17	4x15	22	22	11
6	109	24.5	60	17	5x15	22	22	11

Normal profile A/F
Main line connection G1/4
 Number Dimensions [mm]
 of ports A B C E F G H K

1	46	23	-	23	-	22	22	11
2	61	30.5	-	23	1x15	22	22	11
3	76	30.5	15	23	2x15	22	22	11
4	91	30.5	30	23	3x15	22	22	11
5	106	30.5	45	23	4x15	22	22	11
6	121	30.5	60	23	5x15	22	22	11

PUBLIS/P2 11213 EN · 1-5001-EN

SKF MonoFlex prelubrication distributors of product series 340

General

SKF MonoFlex single-line distributors of product series 340 are 2-, 3-, and 5-port prelubrication distributors for MonoFlex single-line centralized lubrication systems for oil and fluid grease lubrication. These single-line distributors are designed for installation directly on the machine/system requiring lubrication. SKF MonoFlex single-line distributors of product series 340 can be ordered with fittings for the main line connection. This can be indicated on the order by selecting the corresponding letter for the desired fitting in the order code.

The available metered quantities are in the range from 0,01 – 0,16 cm³. The metering nipples have a mark indicating the metered quantity. To better distinguish between different designs, metering nipples for oil are made of brass and metering nipples for fluid grease are made of nickel-plated brass. The lubrication point line can be connected to the metering nipple using SKF quick connectors or solderless pipe connections (DIN 3862) depending on the selected metered quantity. Lubrication point lines can be connected that are made of metal pipe, plastic pipe, or hose lines with metal pipe connectors. The diameter of the lubrication point line that will be connected can be either 2,5 mm or 4 mm. The lubrication point outlet can be closed using a locking pin (SKF quick connector) or a screw plug with a flat washer (solderless pipe connection). The metering nipples for metered quantities above 0,03 cm³ can be replaced later to yield different metered quantities.

The components made of elastomers inside the multi-port single-line distributors are made of NBR or FKM (FPM) depending on the design.

The distributor body is made of zinc die-cast. Holes to secure the multi-port single-line distributors to the machine / system are cast into the distributor body. The main line connection on the distributor body has a counterbore for mounting a solderless pipe connection for metal or plastic pipe diameter of 6 mm (M10x1 thread). Various fittings, from SKF quick connectors to screw plugs, that are matched to the thread size of the main line connection are available.

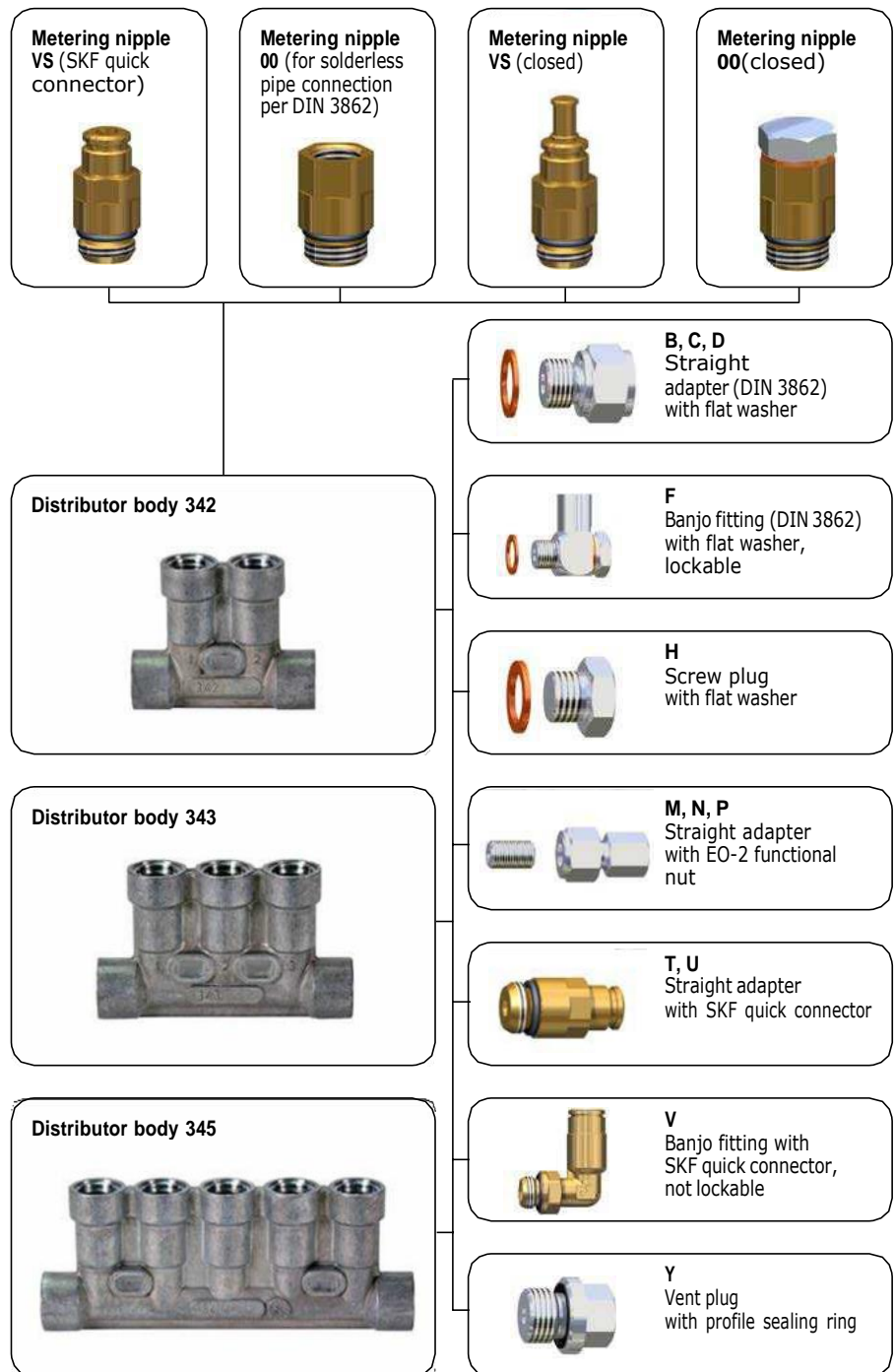

See the following pages for further information on product series 340. Details on accessories for SKF MonoFlex single-line centralized lubrication systems are part of this catalog.

! The main line fittings B – Y can be mounted both on the left and the right side of the distributor body. The configurator on the following page allows specification of a single-line distributor with main line fittings in a single order code.

SKF MonoFlex prelubrication distributors of product series 340

Configurator

Order code

3

4

-

-

-

Product series

Number of metering points (2, 3, 5)

Design and metered quantity					
Design code	2	4	8	5	
Lubricant	Oil	Oil	Oil	Fluid grease	
Lubrication point line [mm]	2,5	4	4	4	
Distributor body material	Zinc die-cast	Zinc die-cast	Zinc die-cast	Zinc die-cast	
Metering nipple material	Brass	Brass	Brass	Brass, nickel-plated	
Elastomer material	NBR	NBR	FKM (FPM)	NBR	
Lubrication point line connection	00	VS 00	VS 00	VS	00
Metered quantity [cm ³]	0,01 ¹⁾	1	1	1	-
	0,02 ¹⁾	-	-	6	-
	0,03	2	2	2	2
	0,06	3	3	3	3
	0,10	4	4	4	4
	0,16	5	5	5	-
	closed ²⁾	V	V	V	V

¹⁾ Subsequent modification of the metered quantity is not technically possible.
²⁾ V = Metered quantity of 0,03 cm³, closed

Order example

342-400-2V000-BB

- Two-port single-line distributor for oil
- NBR design
- Lubrication point line connection per DIN 3862 for pipe ø 4 mm,
- Metered quantity for port 1 = 0,03 cm³
- Metered quantity for port 2 = 0,03 cm³, closed
- Main line fitting left and right = straight adapter (DIN 3862) with flat washer for pipe ø 6 mm

Fittings for main line connection

Description	ø main line [mm]	Code
Straight adapter	6	B
DIN 3862 with flat washer ¹⁾	8	C
	10	D
Banjo fitting DIN 3862 with flat washer, lockable ¹⁾²⁾	6	F
Screw plug with flat washer	-	H
Straight adapter with EO-2 functional nut	6	M
	8	N
	10	P
Straight adapter with SKF quick connector	6	T
	8	U
Banjo fitting with SKF quick connectors, not lockable	6	V
Vent plug with profile sealing ring	-	Y
Without fitting; for solderless pipe connection ¹⁾	6	Z

¹⁾ Solderless pipe connection according to DIN 3862 (operating pressure max. 45 bar)
²⁾ Banjo bolt only inserted in delivery condition, not tightened

SKF MonoFlex prelubrication distributors of product series 340

Dimensions

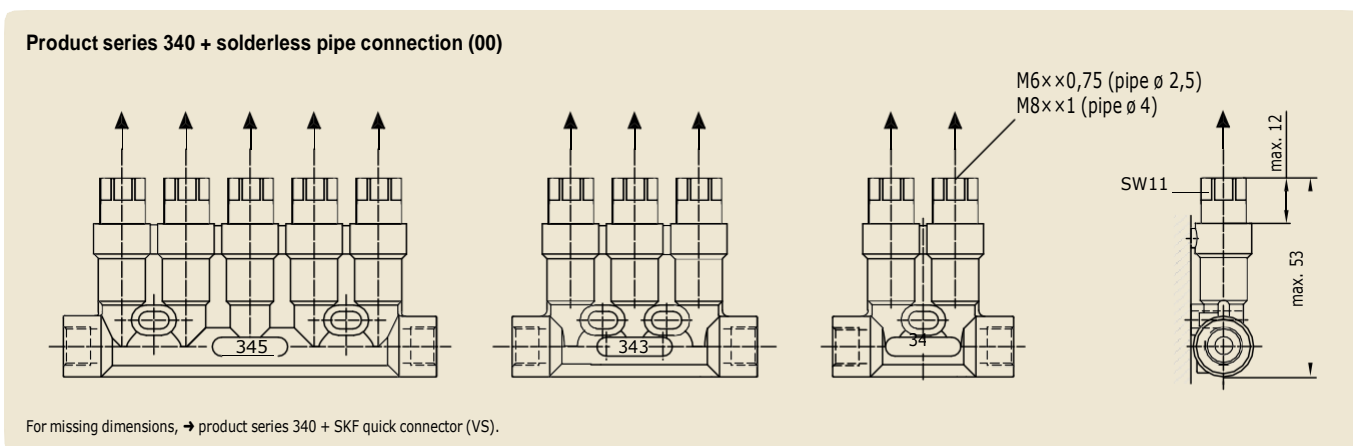
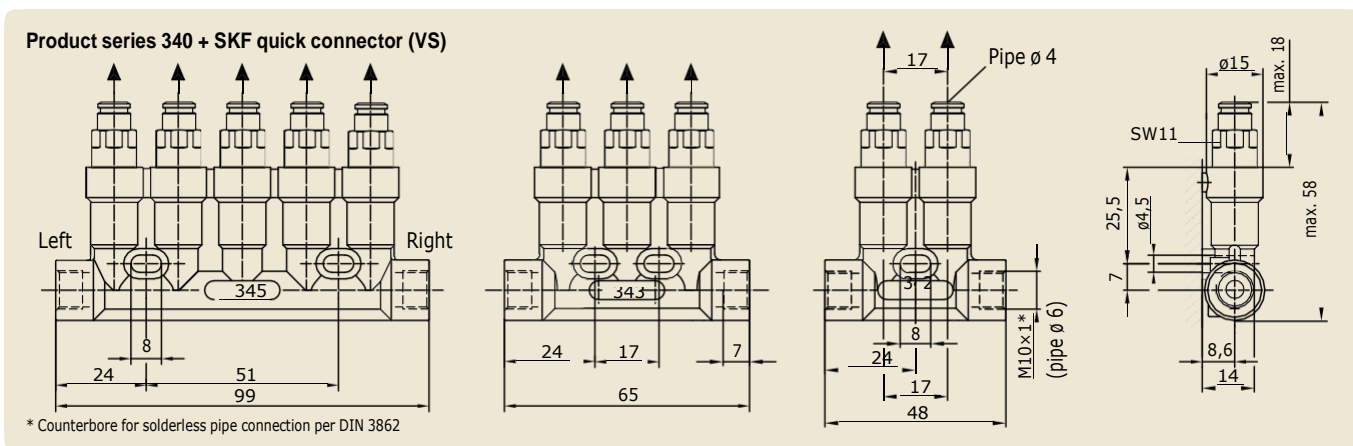

Fittings for main line connection

(→ page 26 for exact designation)

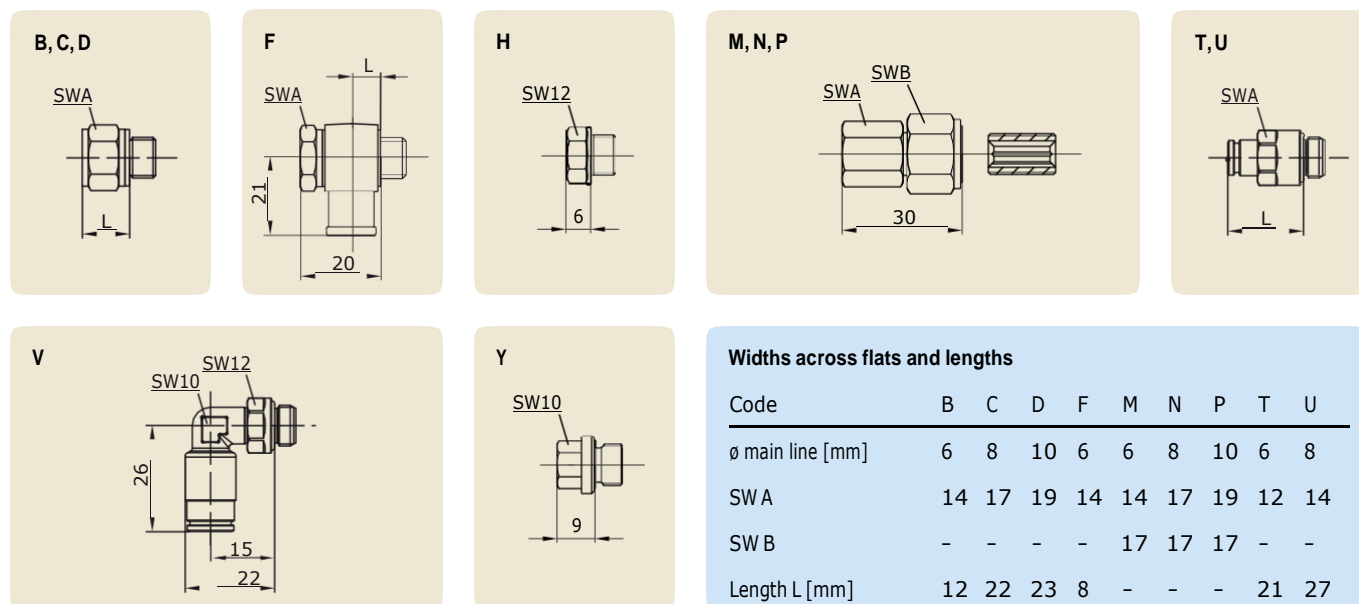

SKF MonoFlex prelubrication distributors of product series 340

Technical data

Product series 340

Lubricant	Metered quantity [cm ³]	Metering nipple	Operating pressure [bar]		Relief pressure [bar]	Operating temperature [°C]
			min.	max.		
Mineral and synthetic oil 20 – 2 000 mm ² /s; compatible with zinc die-cast, FKM (FPM)/NBR, brass, steel	0,01 – 0,02	00	12	45	max. 3	0 – 80
		VS	12	80	max. 3	0 – 80
	0,03 – 0,16	00	6	45	≤ 1	0 – 80
		VS	6	80	≤ 1	0 – 80
Fluid grease of NLGI Grade 000, 00; compatible with zinc die-cast, NBR, brass, steel	0,03 – 0,10	00	12	45	max. 3	0 – 80
		VS	12	80	max. 3	0 – 80

Mark on metering nipple

Metered quantity [cm ³]	Mark
0,01	1
0,02	2
0,03	3
0,06	6
0,10	10
0,16	16

Accessories

Order numbers for metering nipples for oil (replaceable)

ø lubrication point line [mm]	Metering nipple material	Elastomer material	Metering nipple	Metered quantity [cm ³]			
				0,03	0,06	0,10	0,16
2,5	Brass	NBR	00	995-994-003	995-994-006	995-994-010	995-994-016
4	Brass	NBR	VS	995-994-103-VS	995-994-106-VS	995-994-110-VS	995-994-116-VS
4	Brass	NBR	00	995-994-103	995-994-106	995-994-110	995-994-116
4	Brass	FKM (FPM)	VS	341-453-S8-VS	341-456-S8-VS	341-460-S8-VS	341-466-S8-VS
4	Brass	FKM (FPM)	00	341-453-K-S8	341-456-K-S8	341-460-K-S8	341-466-K-S8

Order numbers for metering nipples for fluid grease (replaceable)

ø lubrication point line [mm]	Metering nipple material	Elastomer material	Metering nipple	Metered quantity [cm ³]		
				0,03	0,06	0,10
4	Brass, nickel-plated	NBR	VS	341-853-VS	341-856-VS	341-860-VS
4	Brass, nickel-plated	NBR	00	341-853-K	341-856-K	341-860-K

Fittings for metering nipples

Description	ø lubrication point line [mm]	Pipe thread	Order number		
			A	B	C
Screw plug with flat washer for solderless pipe connection	2,5	M6x0,75	402-011.U1	–	–
	4	M8x1	404-011.U1	–	–
Locking pin (A) for SKF quick connectors	4	–	450-204-002	–	–
Solderless pipe connection for metal pipeline* consisting of socket union (A) double cone sleeve (B)	2,5	M6x0,75	402-002	402-001	–
	4	M8x1	404-002	404-001	–
Solderless pipe connection for plastic pipe* consisting of socket union (A), reinforcing socket (B), and tapered 4 sleeve (C)	2,5	M6x0,75	402-612	402-603	402-611
			404-612	404-603	404-611

* For more information, → page 14.

SKF MonoFlex prelubrication distributors of product series 351

General

SKF MonoFlex single-line distributors of product series 351 are single-port prelubrication distributors for MonoFlex single-line centralized lubrication systems for oil and fluid grease lubrication. These single-line distributors are designed for installation in manifolds. The combination of these single-line distributors with 1- to 6-port manifolds provides flexible options for designing the lubrication system on the machine/system requiring lubrication. Manifolds customized for product series 351 are available in aluminum and stainless steel designs.

The available metered quantities are in a range from 0,05 – 0,60 cm³. The metering nipples have a mark indicating the metered quantity. To better distinguish between different designs, metering nipples for oil are made of brass and metering nipples for fluid grease are made of nickel-plated brass. Metering nipples made of stainless steel are untreated. The lubrication point line can be connected to the metering nipple using SKF quick connectors or solderless pipe connections (DIN 3862) depending on the selected metered quantity. Lubrication point lines can be connected that are made of metal pipe, plastic pipe, or hose lines with metal pipe connectors. The diameter of the lubrication point line that will be connected is 4 mm. The lubrication point outlet can be closed using a locking pin (SKF quick connector) or a screw plug with a flat washer (solderless pipe connection). The metering

nipples can be replaced later to yield different metered quantities. The components made of elastomers in the interior of the single-line distributors are made of NBR or FKM (FPM) depending on the design.

The distributor body is available in aluminum or stainless steel designs. The seal of the internal thread for mounting the single-port single-line distributor in a manifold is available in a flat washer design.

A sealing ring made of stainless steel will be used if a distributor body made of stainless steel is used.

See the following pages for further information on product series 351. Details on accessories for SKF MonoFlex single-line centralized lubrication systems are part of this catalog.

 The configurator on the following page **does not** allow specification of manifolds and distributors in a single order code. The manifolds are listed under Accessories and must be ordered separately.

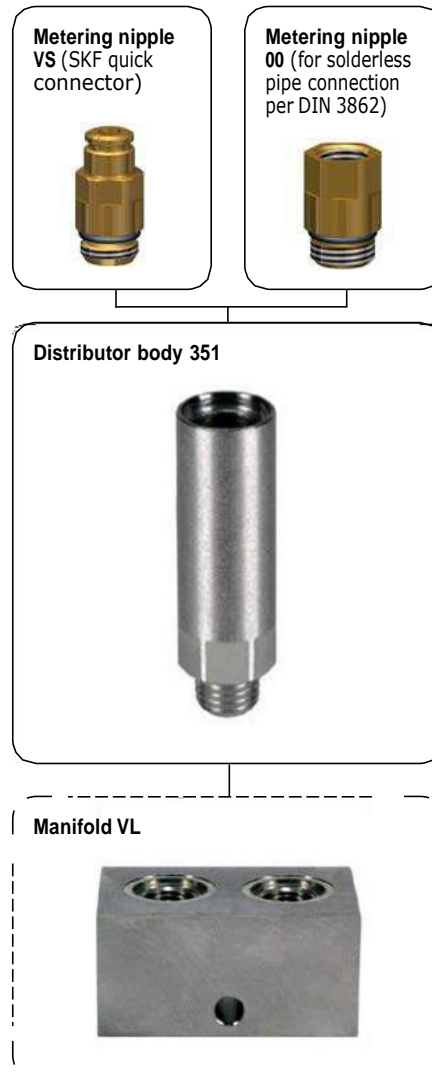

Technical data

Product series 351

Lubricant	Metered quantity [cm ³]	Metering nipple	Operating pressure [bar]		Relief pressure [bar]	Operating temperature [°C]
			min.	max.		
Mineral and synthetic oil 20 – 2 000 mm ² /s; compatible with aluminum, FKM (FPM) / NBR, brass, steel	0,05 – 0,60	00	6	45	< 1	0 – 80
		VS	6	80		
Fluid grease of NLGI Grade 000, 00; compatible with aluminum, FKM (FPM) / NBR, brass	0,10 – 0,60	00	12	45	max. 3	0 – 80
		VS	12	80		

Tightening torque for assembly

Distributor	Seal	Tightening torques [Nm]
351-xxx-x0000-00	Flat washer	10
351-xxx-x0000-00	Stainless steel ring	10

SKF MonoFlex prelubrication distributors of product series 351

Configurator

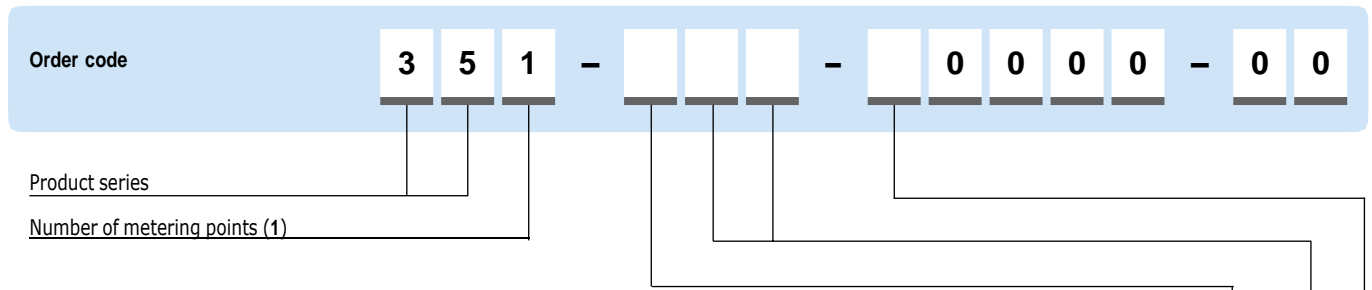

Design and metered quantity																
Design code	0		8		4		1		7		2		3		6	
Lubricant	Oil		Oil		Oil		Fluid grease		Fluid grease		Oil		Fluid grease		Oil	
ø lubrication point line [mm]	4		4		4		4		4		4		4		4	
Distributor body material	Aluminum		Aluminum		Stainless steel (1.4305)		Aluminum		Aluminum		Aluminum		Aluminum		Stainless steel (1.4305)	
Metering nipple material	Brass		Brass		Stainless steel (1.4305)		Brass nickel-plated		Brass nickel-plated		Brass		Brass nickel-plated		Stainless steel (1.4305)	
Elastomer material	NBR		FKM (FPM)		FKM (FPM)		NBR		FKM (FPM)		NBR		NBR		FKM (FPM)	
Threaded seal material	Flat washer ¹⁾		Flat washer ¹⁾		Stainless steel ring ²⁾ (1.4571)		Flat washer ¹⁾		Flat washer ¹⁾		O-ring ³⁾		O-ring ³⁾		O-ring ³⁾	
Lubrication point line connection	VS	00	VS	00	00		VS	00	VS	00	VS	00	VS	00	00	
Metered quantity code [cm ³]	0,05	3	3	3	3	-	-	-	-	-	-	-	-	-	-	-
	0,10	4	4	4	4	4	4	4	4	4	4	4	4	4	4	4
	0,20	5	5	5	5	5	5	5	5	5	5	5	5	5	5	5
	0,30	-	-	-	-	-	6	6	6	6	-	-	6	6	-	-
	0,40	6	6	6	6	6	-	-	-	-	6	6	-	-	6	6
	0,60	7	7	7	7	7	-	7	-	-	7	7	-	-	7	7

¹⁾ Flat washer must be ordered separately. Order number: **504-019**
²⁾ Stainless steel ring must be ordered separately. Order number: **99-1031-7603**
³⁾ O-ring is part of the shipment

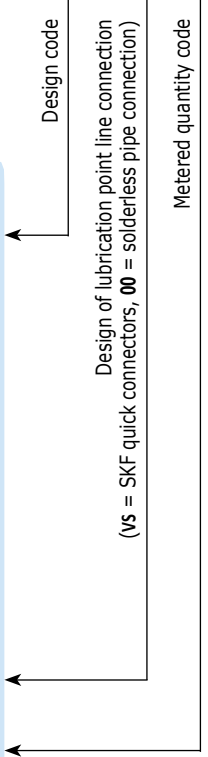

Order example

351-100-70000-00

- Single-port single-line distributor for fluid grease
- NBR design
- Lubrication point line connection per DIN 3862 for pipe ø 4 mm
- Metered quantity 0,60 cm³
- With flat washer seal on internal thread

PUBLS/P2 11213 EN · 1-5001-EN

SKF MonoFlex prelubrication distributors of product series 351

Dimensions

Product series 351 + SKF quick connector (VS) with seal

Product series 351 + SKF quick connector (VS) with O-ring seal

Product series 351 + solderless pipe connection (00) with seal

Product series 351 + solderless pipe connection (00) with O-ring seal

Mark on metering nipple

Metered quantity [cm ³]	Mark
0,05	0,05
0,10	0,1
0,20	0,2
0,30	0,3
0,40	0,4
0,60	0,6

Accessories

Order numbers for metering nipples for oil (replaceable)

ø lubrication point line [mm]	Metering nipple material	Elastomer material	Metering nipple	Metered quantity [cm ³]				
				0,05	0,10	0,20	0,40	0,60
4	Brass	NBR	00	352-005-K	352-010-K	352-020-K	352-040-K	352-060-K
4	Brass	NBR	VS	352-005-VS	352-010-VS	352-020-VS	352-040-VS	352-060-VS
4	Brass	FKM (FPM)	00	352-005-K-S8	352-010-K-S8	352-020-K-S8	352-040-K-S8	352-060-K-S8
4	Brass	FKM (FPM)	VS	352-005-S8-VS	352-010-S8-VS	352-020-S8-VS	352-040-S8-VS	352-060-S8-VS
4	Stainless steel (1.4305)	FKM (FPM)	00	-	352-010-K-S3	352-020-K-S3	352-040-K-S3	352-060-K-S3

Order numbers for metering nipples for fluid grease (replaceable)

ø lubrication point line [mm]	Metering nipple material	Elastomer material	Metering nipple	Metered quantity [cm ³]			
				0,10	0,20	0,30	0,60
4	Brass, nickel-plated	NBR	00	995-993-610	995-993-620	995-993-630	995-993-660
4	Brass, nickel-plated	NBR	VS	995-993-610-VS	995-993-620-VS	995-993-630-VS	-
4	Brass, nickel-plated	FKM (FPM)	00	352-010-K-S82	352-020-K-S82	352-030-K-S82	-
4	Brass, nickel-plated	FKM (FPM)	VS	352-010-S82-VS	352-020-S82-VS	352-030-S82-VS	-

Fittings for metering nipples

Description	ø lubrication point line [mm]	Pipe thread	Order number A	B	C
Screw plug with flat washer for solderless pipe connection	4	M8x1	404-011.U1	-	-
Locking pin (A) for SKF quick connectors	4	-	450-204-002	-	-
Solderless pipe connection for metal pipeline* consisting of socket union (A) and double cone sleeve (B)	4	M8x1	404-002	404-001	-
Solderless pipe connection for plastic pipe* consisting of 4 of socket union (A), reinforcing socket (B), and tapered sleeve (C)		M8x1	404-612	404-603	404-611

* For more information, → page 14.

SKF MonoFlex prelubrication distributors of product series 351

Manifolds for product series 351

Order code

V L -

Product series

Number of ports
01 = 1 screw-in point **04** = 4 screw-in points
02 = 2 screw-in points **05** = 5 screw-in points
03 = 3 screw-in points **06** = 6 screw-in points
 (other numbers of ports available on request)

Design of distributor pipe thread
B = Normal profile, M10x1 with counterbore for O-ring
E = Small profile, M10x1 with counterbore for flat washer
 (can only be selected for main line connection M3)
G = Normal profile, M10x1 with counterbore for flat washer

Material
A = Aluminum
E = Stainless steel (1.4305) (can only be selected for normal profile)

Design of main line connection
G1 = G1/8 per DIN 3852-2, Form X, schmal
G2 = G1/4 per DIN 3852-2, Form X, schmal
M3 = M10x1 with counterbore for solderless pipe connection per DIN 3862 (→ page 14)
M4 = M14x1,5 with counterbore for solderless pipe connection per DIN 3862 (→ page 14)
 (can only be selected for normal profile)

Order example

VL-02BAM3

- Product series VL
- 2 ports
- Normal profile made of aluminum
- M10x1 internal thread with counterbore for O-ring
- M10x1 main line connection with counterbore for solderless pipe connection per DIN 3862

Dimensions

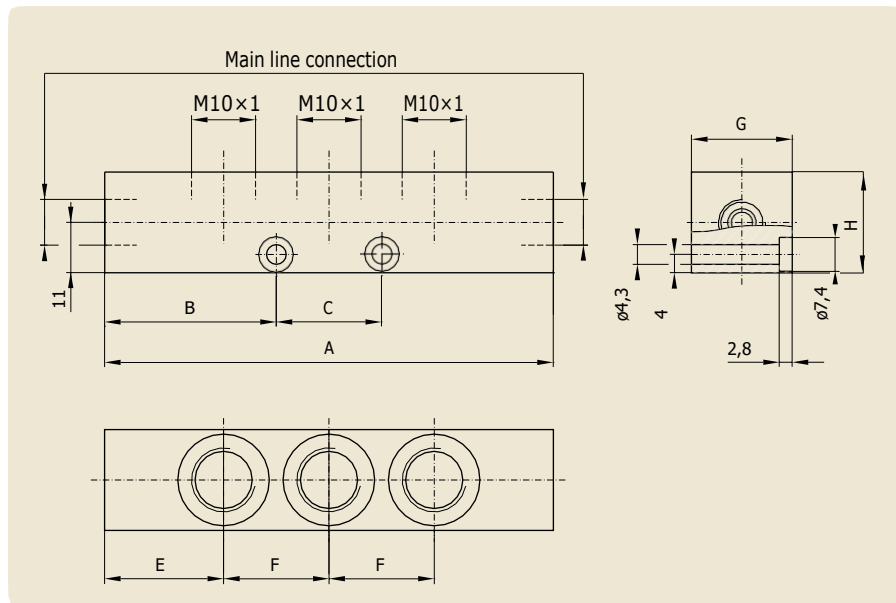

Normal profile B/G
Main line connection M10x1
 Number of ports Dimensions [mm]

of ports	A	B	C	E	F	G	H
1	40	20	-	20	-	22	22
2	57	28,5	-	20	1x17	22	22
3	74	28,5	17	20	2x17	22	22
4	91	28,5	34	20	3x17	22	22
5	108	28,5	51	20	4x17	22	22
6	125	28,5	68	20	5x17	22	22

Normal profile B/G
Main line connection M14x1,5
 Number of ports Dimensions [mm]

of ports	A	B	C	E	F	G	H
1	52	26	-	26	-	22	22
2	69	34,5	-	26	1x17	22	22
3	86	34,5	17	26	2x17	22	22
4	103	34,5	34	26	3x17	22	22
5	128	34,5	51	26	4x17	22	22
6	137	34,5	68	26	5x17	22	22

Small profile E
Main line connection M10x1
 Number of ports Maße [mm]

of ports	A	B	C	E	F	G	H
1	41	20,5	-	20,5	-	18	20
2	58	29	-	20,5	1x17	18	20
3	75	37,5	-	20,5	2x17	18	20
4	92	29	34	20,5	3x17	18	20
5	109	29	51	20,5	4x17	18	20
6	126	29	68	20,5	5x17	18	20

Normal profile B/G
Main line connection G1/8
 Number of ports Dimensions [mm]

of ports	A	B	C	E	F	G	H
1	34	17	-	17	-	22	22
2	51	25,5	-	17	1x17	22	22
3	68	25,5	17	17	2x17	22	22
4	85	25,5	34	17	3x17	22	22
5	102	25,5	51	17	4x17	22	22
6	119	25,5	68	17	5x17	22	22

Normal profile B/G
Main line connection G1/4
 Number of ports Dimensions [mm]

of ports	A	B	C	E	F	G	H
1	46	23	-	23	-	22	22
2	63	31,5	-	23	1x17	22	22
3	80	31,5	17	23	2x17	22	22
4	97	31,5	34	23	3x17	22	22
5	114	31,5	51	23	4x17	22	22
6	131	31,5	68	23	5x17	22	22

PUBLS/P2 11213 EN · 1-5001-EN

SKF MonoFlex prelubrication distributors of product series 350

General





SKF MonoFlex single-line distributors of product series 350 are 2-, 3-, and 5-port prelubrication distributors for MonoFlex single-line centralized lubrication systems for oil and fluid grease lubrication. These single-line distributors are designed for installation directly on the machine/system requiring lubrication. SKF MonoFlex single-line distributors of product series 350 can be ordered with fittings for the main line connection. This can be indicated on the order by selecting the corresponding letter for the desired fitting in the order code.

The available metered quantities are in a range from 0,05 – 0,60 cm³. The metering nipples have a mark indicating the metered quantity. To better distinguish between different designs, metering nipples for oil are made of brass and metering nipples for fluid grease are made of nickel-plated brass.

The lubrication point line can be connected to the metering nipple using SKF quick connectors or solderless pipe connections (DIN 3862) depending on the selected metered quantity. Lubrication point lines can be connected that are made of metal pipe, plastic pipe, or hose lines with metal pipe connectors. The diameter of the lubrication point line that will be connected is 4 mm. The lubrication point outlet can be closed using a locking pin (SKF quick connector) or a screw plug with a flat washer (solderless pipe connection). The metering nipples can be replaced later to yield different metered quantities.

The components made of elastomers inside the multi-port single-line distributors are made of NBR or FKM (FPM) depending on the design.

The distributor body is made of zinc die-cast. Holes to secure the multi-port single-line distributors to the machine/system are cast in the distributor body. The main line connection on the distributor body has an M12x1 thread. Various fittings, from SKF quick connectors to screw plugs, that are matched to the thread size of the main line connection are available.

<p>Metering nipple VS (SKF quick connector)</p> 	<p>Metering nipple 00 (for solderless pipe connection per DIN 3862)</p> 	<p>Metering nipple VS (closed)</p> 	<p>Metering nipple 00 (closed)</p> 
<p>Distributor body 352</p> 		<p>B, C, D Straight adapter (DIN 3862) with flat washer</p> 	
<p>Distributor body 353</p> 		<p>E, F Banjo fitting (DIN 3862) with flat washer, lockable</p> 	
<p>Distributor body 355</p> 		<p>H Screw plug with flat washer</p> 	
		<p>M, N, P, R Straight adapter with EO-2 functional nut</p> 	
		<p>S, T Straight adapter with SKF quick connector</p> 	
		<p>W, X Banjo fitting with SKF quick connector, not lockable</p> 	

See the following pages for further information on product series 350. Details on accessories for SKF MonoFlex single-line centralized lubrication systems are part of this catalog.

! The main line fittings B – X can be mounted both on the left and the right of the distributor body. The configurator on the following page allows specification of a single-line distributor with main line fittings in a single order code.

SKF MonoFlex prelubrication distributors of product series 350

Dimensions

Product series 350 + SKF quick connectors (VS)

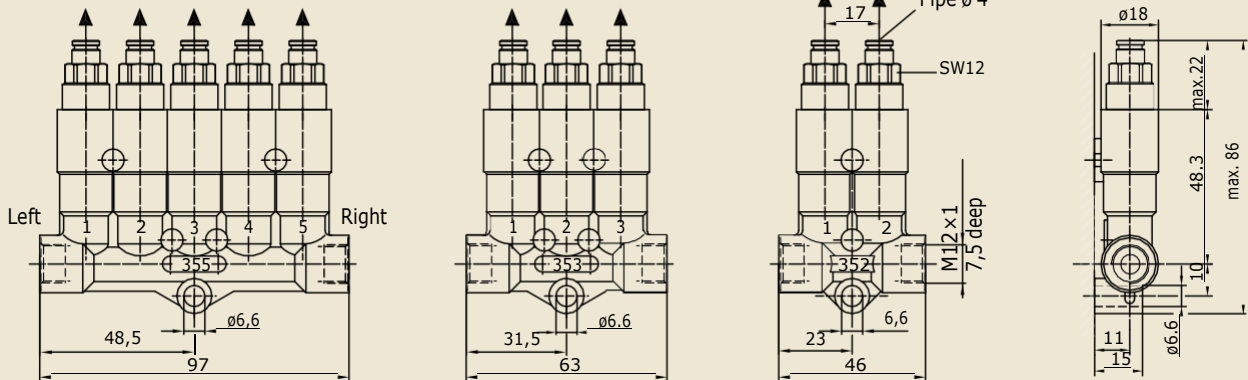

Product series 350 + solderless pipe connection (00)

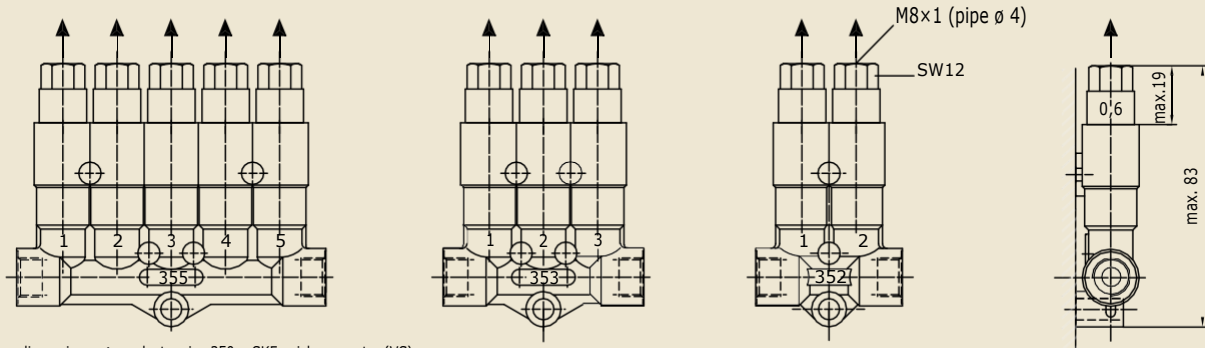

For missing dimensions, → product series 350 + SKF quick connector (VS).

Fittings for main line connection

(→ page 34 for exact designation)

B, C, D

E

F

H

M, N, P, R

S, T

W

X

Widths across flats and lengths											
Code	B	C	D	E	F	M	N	P	R	S	T
ϕ main line [mm]	6	8	10	6	8	6	8	10	12	6	8
SWA	17	17	19	17	17	14	17	19	22	14	14
SWB	-	-	-	-	-	19	19	19	19	-	-
Length L [mm]	10	20	22	25	27	32	32	31	31	21	26

SKF MonoFlex prelubrication distributors of product series 350

Technical data

Product series 350							Mark on metering nipple	
Lubricant	Metered quantity [cm ³]	Metering nipple	Operating pressure [bar]		Relief pressure [bar]	Operating temperature [°C]	Metered quantity [cm ³]	Mark
			min.	max.				
Mineral and synthetic oil 20 – 2 000 mm ² /s; compatible with zinc die-cast, FKM (FPM)/ NBR, brass, steel	0,05 – 0,60	00	6	45	≤ 1	0 – 80	0,05	0,05
		VS	6	80	≤ 1	0 – 80	0,10	0,1
Fluid grease of NLGI Grade 000, 00; compatible with zinc die-cast, NBR, brass, steel	0,10 – 0,60	00	12	45	max. 3	0 – 80	0,20	0,2
		VS	12	80	max. 3	0 – 80	0,30	0,3
							0,40	0,4
							0,60	0,6

Accessories

Order numbers for metering nipples for oil* (replaceable)

ø lubrication point line [mm]	Elastomer material	Metering nipple	Metered quantity [cm ³]				
			0,05	0,10	0,20	0,40	0,60
4	NBR	00	352-005-K	352-010-K	352-020-K	352-040-K	352-060-K
4	NBR	VS	352-005-VS	352-010-VS	352-020-VS	352-040-VS	352-060-VS
4	FKM (FPM)	00	352-005-K-S8	352-010-K-S8	352-020-K-S8	352-040-K-S8	352-060-K-S8
4	FKM (FPM)	VS	352-005-S8-VS	352-010-S8-VS	352-020-S8-VS	352-040-S8-VS	352-060-S8-VS

* Metering nipples are made of brass.

Order numbers for metering nipples for fluid grease* (replaceable)

ø lubrication point line [mm]	Elastomer material	Metering nipple	Metered quantity [cm ³]			
			0,10	0,20	0,30	0,60
4	NBR	00	995-993-610	995-993-620	995-993-630	995-993-660
4	NBR	VS	995-993-610-VS	995-993-620-VS	995-993-630-VS	–
4	FKM (FPM)	00	352-010-K-S82	352-020-K-S82	352-030-K-S82	–
4	FKM (FPM)	VS	352-010-S82-VS	352-020-S82-VS	352-030-S82-VS	–

* Metering nipples are made of nickel-plated brass.

Fittings for metering nipples

Description	ø lubrication point line [mm]	Pipe thread	Order number		
			A	B	C
Screw plug with flat washer for solderless pipe connection	4	M8x1	404-011.U1	–	–
Locking pin (A) for SKF quick connectors	4	–	450-204-002	–	–
Solderless pipe connection for metal pipeline* consisting of socket union (A) and double cone sleeve (B)	4	M8x1	404-002	404-001	–
Solderless pipe connection for plastic pipe* consisting of socket union (A), reinforcing socket (B), and tapered sleeve (C)	4	M8x1	404-612	404-603	404-611

* For more information, → page 14.

SKF MonoFlex prelubrication distributors of product series 391

General

SKF MonoFlex single-line distributors of product series 391 are single-port prelubrication distributors for MonoFlex single-line centralized lubrication systems for oil and fluid grease lubrication. These single-line distributors are designed for installation in manifolds. The combination of these single-line distributors with 1- to 6-port manifolds provides flexible options for designing the lubrication system on the machine/system requiring lubrication. Manifolds customized for product series 391 are available in an aluminum design.

The available metered quantities are a range from 0,10 – 1,5 cm³. The metering nipples have a mark indicating the metered quantity. To better distinguish between different designs, metering nipples for oil are made of brass and metering nipples for fluid grease are made of nickel-plated brass. The lubrication point line is connected to the metering nipple using a solderless pipe connection (DIN 3862). Lubrication point lines can be connected that are made of metal pipe, plastic pipe, or hose lines with metal pipe connectors. The diameter of the lubrication point line that will be connected is 4 mm. The lubrication point outlet can be closed using a screw plug with a flat washer. The metering nipples can be replaced later to yield different metered quantities. The components made of elastomers in the interior of the single-line distributors are

made of NBR or FKM (FPM) depending on the design.

The distributor body is available in an aluminum design. The seal of the internal thread for mounting the single-port single-line distributor in a manifold is available in a flat washer design.

See the following pages for further information on product series 391. Details on accessories for SKF MonoFlex single-line centralized lubrication systems are part of this catalog.

 The configurator on the following page **does not** allow specification of manifolds and distributors in a single order code. The manifolds are listed under Accessories and must be ordered separately.

Metering nipple 00 (for solderless pipe connection per DIN 3862)



Distributor body 391



Manifold VL



Technical data

Product series 391

Lubricant	Metered quantity [cm ³]	Metering nipple	Operating pressure [bar]		Relief pressure [bar]	Operating temperature [°C]
			min.	max.		
Mineral and synthetic oil 20 – 2 000 mm ² /s; compatible with aluminum, FKM (FPM) / NBR, brass, steel	0,2 – 1,5	00	8	45	≤ 1	0 – 80
Fluid grease of NLGI Grade 000, 00, 0; compatible with aluminum, NBR, brass, steel	0,1 – 0,3	00	26	45	max. 7	0 – 80

Tightening torque for assembly

Distributor	Seal	Tightening torques [Nm]
391-8xx-x000-00	Flat washer	16

SKF MonoFlex prelubrication distributors of product series 391

Configurator

Order code **3** **9** **1** - **0** **0** - **0** **0** **0** **0** - **0** **0**

Product series 3 9 1

Number of metering points (1) 1

Design code 0 0

Design of lubrication point line connection (vs = SKF quick connectors, 00 = solderless pipe connection)

Metered quantity code 0 0 0 0

Design and metered quantity			
Design code	0	8	1
Lubricant	Oil	Oil	Fluid grease
∅ lubrication point line [mm]	4	4	4
Distributor body material	Aluminum	Aluminum	Aluminum
Metering nipple material	Brass	Brass	Brass, nickel-plated
Elastomer material	NBR	FKM (FPM)	NBR
Threaded seal material	Flat washer*	Flat washer*	Flat washer*
Lubrication point line connection	00	00	00
Metered quantity code [cm ³]	0,10 0,20 0,30 0,40 0,60 1,00 1,50	- 5 - 6 7 8 9	4 5 6 - - -

* Flat washer must be ordered separately. Order number: DIN7603-A14x18-CU

Order example

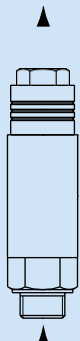

391-100-60000-00

- Single-port single-line distributor for fluid grease
- NBR design
- Lubrication point line connection per DIN 3862 for pipe ∅ 4 mm
- Metered quantity 0,30 cm³
- Flat washer seal on internal thread

SKF MonoFlex prelubrication distributors of product series 391

Dimensions

Product series 391 for oil + solderless pipe connection (00)

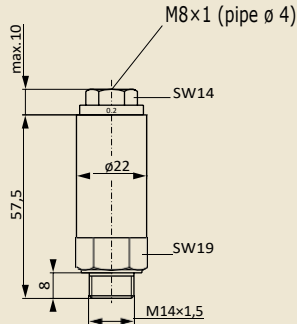

Product series 391 for fluid grease + solderless pipe connection (00)

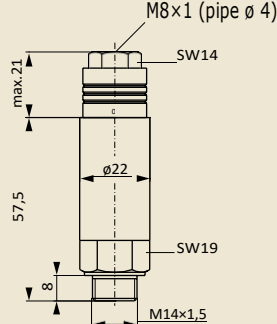

Mark on metering nipple

Metered quantity [cm ³]	Mark
0,1	0,1
0,2	0,2
0,3	0,3
0,4	0,4
0,6	0,6
1,0	1,0
1,5	1,5

Accessories

Order numbers for metering nipples for oil (replaceable)

ø lubrication point line [mm]	Elastomer material	Metering nipple material	Metered quantity [cm ³]				
			0,2	0,4	0,6	1,0	1,5
4	NBR	Brass	391-020-K	391-040-K	391-060-K	391-100-K	391-150-K-S8
4	FKM (FPM)	Brass	391-020-K-S8	391-040-K-S8	391-060-K-S8	391-100-K-S8	391-150-K-S8

Order numbers for metering nipples made of nickel-plated brass for fluid grease (replaceable)

ø lubrication point line [mm]	Elastomer material	Metering nipple material	Metered quantity [cm ³]		
			0,1	0,2	0,3
4	NBR	Brass, nickel-plated	391-010-K-S1	391-020-K-S1	391-030-K-S1

Fittings for metering nipples

Description	ø lubrication point line [mm]	Pipe thread	Order number		
			A	B	C
Screw plug with flat washer for solderless pipe connection	4	M8x1	404-011.U1	-	-
Solderless pipe connection for metal pipeline* consisting of socket union (A) and double cone sleeve (B)	4	M8x1	404-002	404-001	-
Solderless pipe connection for plastic pipe* consisting of socket union (A), reinforcing socket (B), and tapered sleeve (C)	4	M8x1	404-612	404-603	404-611

* For more information, → page 14.

SKF MonoFlex prelubrication distributors of product series 391

Manifolds for product series 391

Order code

V L - C A

Product series

Number of ports
01 = 1 screw-in point **04** = 4 screw-in points
02 = 2 screw-in points **05** = 5 screw-in points
03 = 3 screw-in points **06** = 6 screw-in points
 (other numbers of ports available on request)

Design of distributor pipe thread
C = Normal profile, M14x1,5 with counterbore for flat washer

Material
A = Aluminum

Design of main line connection
G1 = G1/8 per DIN 3852-2, Form X, schmal
G2 = G1/4 per DIN 3852-2, Form X, schmal
M3 = M10x1 with counterbore for solderless pipe connection per DIN 3862 (→ page 14)
M4 = M14x1,5 with counterbore for solderless pipe connection per DIN 3862 (→ page 14)

Order example

VL-02CAM3

- Product series VL
- 2 ports
- Normal profile made of aluminum
- M14x1,5 internal thread with counterbore for flat washer
- M10x1 main line connection with counterbore for solderless pipe connection per DIN 3862

Dimensions

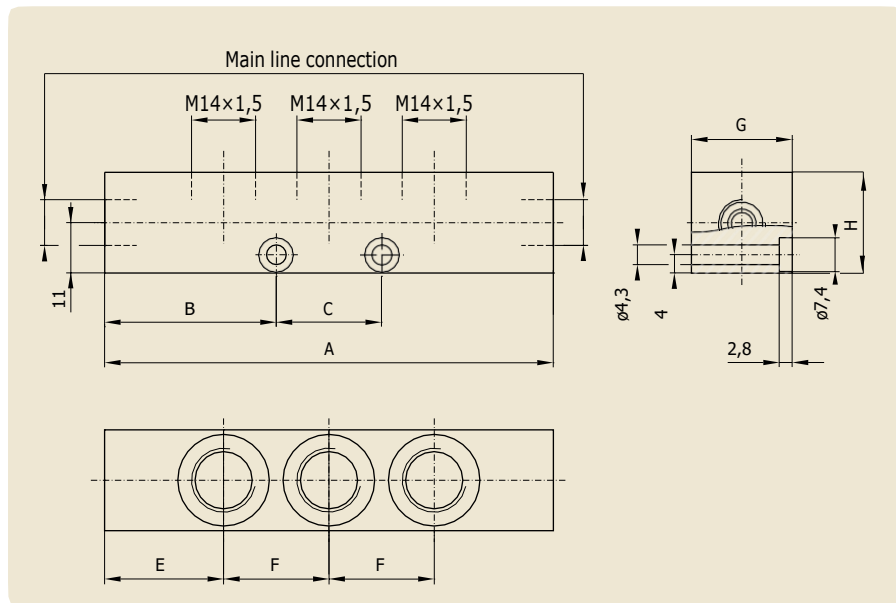

Normal profile C
Main line connection M10x1
 Number of ports Dimensions [mm]

Number of ports	A	B	C	E	F	G	H
1	60	18	24	30	-	22	22
2	70	35	-	29	1x24	22	22
3	94	35	24	23	2x24	22	22
4	118	35	48	23	3x24	22	22
5	142	35	72	23	4x24	22	22
6	166	35	96	23	5x24	22	22

Normal profile C
Main line connection M14x1,5
 Number of ports Dimensions [mm]

Number of ports	A	B	C	E	F	G	H
1	68	22	24	34	-	22	22
2	78	39	-	27	1x24	22	22
3	102	39	24	27	2x24	22	22
4	126	39	48	27	3x24	22	22
5	150	39	72	27	4x24	22	22
6	174	39	96	27	5x24	22	22

Normal profile C
Main line connection G1/8
 Number of ports Dimensions [mm]

Number of ports	A	B	C	E	F	G	H
1	54	15	24	27	-	22	22
2	64	32	-	20	1x24	22	22
3	88	32	24	20	2x24	22	22
4	112	32	48	20	3x24	22	22
5	136	32	72	20	4x24	22	22
6	160	32	96	20	5x24	22	22

Normal profile C
Main line connection G1/4
 Number of ports Dimensions [mm]

Number of ports	A	B	C	E	F	G	H
1	64	20	24	32	-	22	22
2	76	38	-	26	1x24	22	22
3	100	38	24	26	2x24	22	22
4	124	38	48	26	3x24	22	22
5	148	38	72	26	4x24	22	22
6	172	38	96	26	5x24	22	22

PUBLS/P2 11213 EN · 1-5001-EN

SKF MonoFlex prelubrication distributors of product series 390

General

SKF MonoFlex single-line distributors of product series 390 are 2- and 3-port prelubrication distributors for MonoFlex single-line centralized lubrication systems for oil and fluid grease lubrication. These single-line distributors are designed for installation directly on the machine/system requiring lubrication. SKF MonoFlex single-line distributors of product series 390 can be ordered with fittings for the main line connection.

This can be indicated on the order by selecting the corresponding letter for the desired fitting in the order code.

The available metered quantities are in a range from 0,10 – 1,5 cm³. The metering nipples have a mark indicating the metered quantity. To better distinguish between different designs, metering nipples for oil are made of brass and metering nipples for fluid grease are made of nickel-plated brass.

The lubrication point line is connected to the metering nipple using a solderless pipe connection (DIN 3862). Lubrication point lines can be connected that are made of metal pipe, plastic pipe, or hose lines with metal pipe connectors. The diameter of the lubrication point line that will be connected is 4 mm. The lubrication point outlet can be closed using a screw plug with a flat washer. The metering nipples can be replaced later to yield different metered quantities.

The components made of elastomers inside the multi-port single-line distributors are made of NBR or FKM (FPM) depending on the design.

The distributor body is made of zinc die-cast. Holes to secure the multi-port single-line distributors to the machine/system are cast in the distributor body.

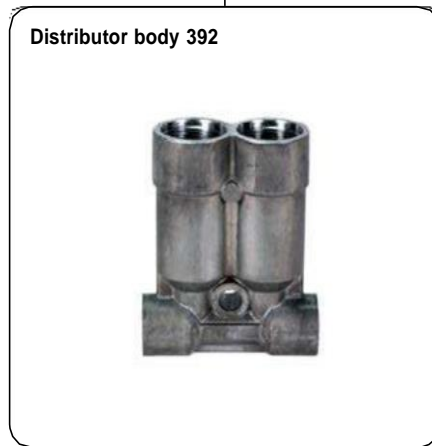

! The main line fittings B–X can be mounted both on the left and the right of the distributor body. The configurator on the following page allows specification of a single-line distributor with main line fittings in a single order code.

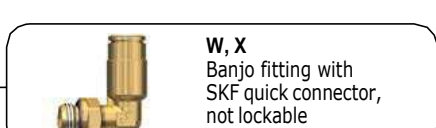
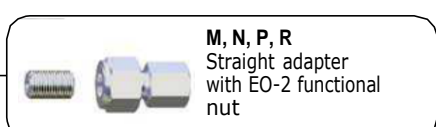
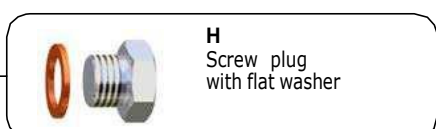
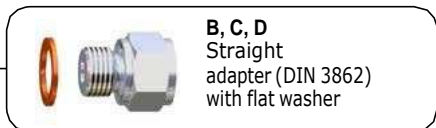

The main line connection on the distributor body has an M12x1 thread. Various fittings, from SKF quick connectors to screw plugs, that are matched to the thread size of the main line connection are available.

See the following pages for further information on product series 390. Details on accessories for SKF MonoFlex single-line centralized lubrication systems are part of this catalog.

SKF MonoFlex prelubrication distributors of product series 390

Configurator

Order code

3 9 - 0 0 - 0 0 -

Product series

Number of metering points (2, 3)

Code

Design of lubrication point line connection
(00 = solderless pipe connection)

Metering point 1

Metering point 2

Metering point 3
(0 = not present, on 392)

Metered quantity code

Code for fittings for main line connection on left

Code for fittings for main line connection on right

Design and metered quantity

Design code	0	8	1
Lubricant	Oil	Oil	Fluid grease
∅ lubrication point line [mm]	4	4	4
Distributor body material	Zinc die-cast	Zinc die-cast	Zinc die-cast
Metering nipple material	Brass	Brass	Brass, nickel-plated
Elastomer material	NBR	FKM (FPM)	NBR
Lubrication point line connection	00	00	00
	0,10	-	4
	0,20	5	5
	0,30	-	6
	0,40	6	-
	0,60	7	-
	1,00	8	-
	1,50	9	-
	closed *	V	V

* V = Metered quantity of 0,20 cm³, closed

Order example

392-800-5V000-CC

- Two-port single-line distributor for oil
- FPM design
- Lubrication point line connection per DIN 3862 for pipe ∅ 4 mm
- Metered quantity for port 1 = 0,20 cm³
- Metered quantity for port 2 = 0,20 cm³ closed
- Main line fitting left and right = straight adapter (DIN 3862) with flat washer for pipe ∅ 8 mm

Fittings for main line connection

Description	∅ main line [mm]	Code
Straight adapter	6	B
DIN 3862 with flat washer	8	C
	10	D
Banjo fitting DIN 3862 with flat washer, lockable ¹⁾	6	E
	8	F
Screw plug with flat washer	-	H
Straight adapter with EO-2 functional nut	6	M
	8	N
	10	P
	12	R
Straight adapter with SKF quick connector	6	S
	8	T
Banjo fitting with SKF quick connector, not lockable	6	W
	8	X
Without fitting (M12x1 thread)	-	Z

¹⁾ Banjo bolt only inserted in delivery condition, not tightened

SKF MonoFlex prelubrication distributors of product series 390

Dimensions

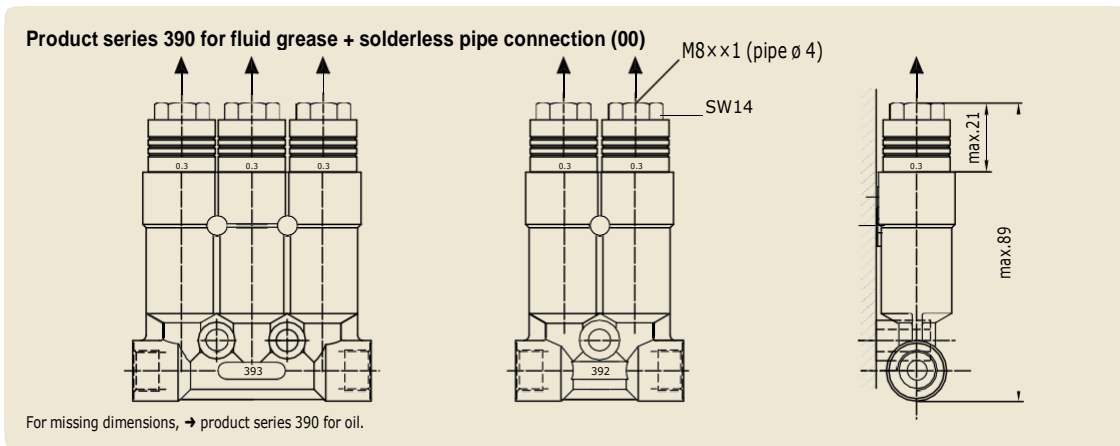
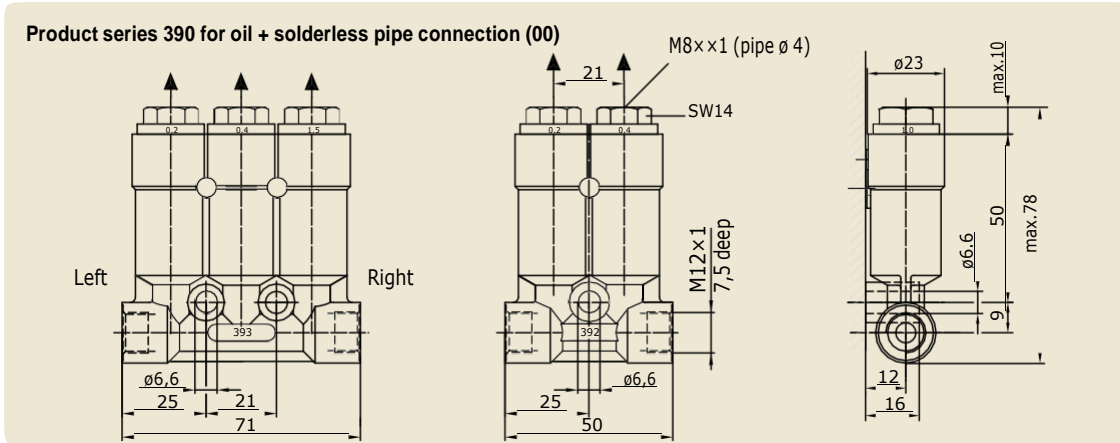

Fittings for main line connection (→ page 42 for exact designation)

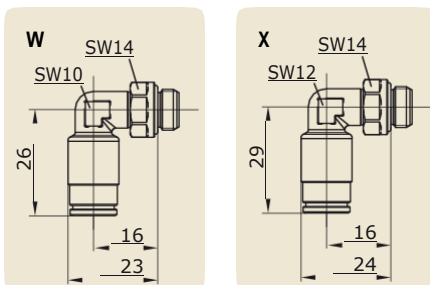
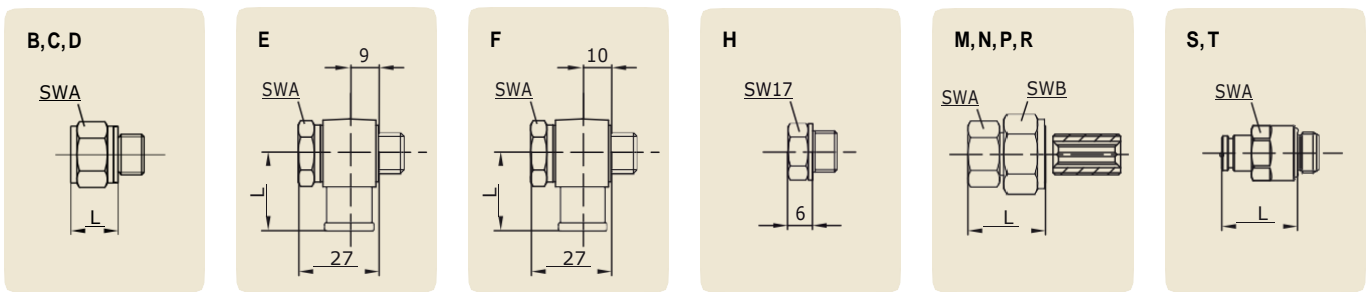

Widths across flats and lengths										
Code	B	C	D	E	F	M	N	P	R	T
ø main line [mm]	6	8	10	6	8	6	8	10	12	8
SWA	17	17	19	17	17	14	17	19	22	14
SWB	-	-	-	-	-	19	19	19	19	-
Length L [mm]	10	20	22	25	27	32	32	31	31	26

SKF MonoFlex prelubrication distributors of product series 390

Technical data

Product series 390							Mark on metering nipple	
Lubricant	Metered quantity [cm ³]	Metering nipple	Operating pressure [bar]		Relief pressure [bar]	Operating temperature [°C]	Metered quantity [cm ³]	Mark
			min.	max.				
Mineral and synthetic oil 20 – 2 000 mm ² /s; compatible with zinc die-cast, FKM (FPM)/NBR, brass, steel	0,2 – 1,5	00	8	45	< 1	0 – 80	0,1 0,2 0,3 0,4 0,6 1,0 1,5	0,1 0,2 0,3 0,4 0,6 1,0 1,5
Fluid grease of NLGI Grade 000, 00, 0; compatible with zinc die-cast, NBR, brass, steel	0,1 – 0,3	00	26	45	max. 7	0 – 80		

Accessories

Order numbers for metering nipples for oil (replaceable)							
ø lubrication point line [mm]	Elastomer material	Metering nipple material	Metered quantity [cm ³]				
			0,2	0,4	0,6	1,0	1,5
4	NBR	Brass	391-020-K	391-040-K	391-060-K	391-100-K	391-150-K
4	FKM (FPM)	Brass	391-020-K-S8	391-040-K-S8	391-060-K-S8	391-100-K-S8	391-150-K-S8

Order numbers for metering nipples for fluid grease (replaceable)					
ø lubrication point line [mm]	Elastomer material	Metering nipple material	Metered quantity [cm ³]		
			0,1	0,2	0,3
4	NBR	Brass, nickel-plated	391-010-K-S1	391-020-K-S1	391-030-K-S1

Fittings for metering nipples					
Description	ø lubrication point line [mm]	Pipe thread	Order number A	B	C
Screw plug with flat washer for solderless pipe connection	4	M8x1	404-011.U1	–	–
Solderless pipe connection for metal pipeline* consisting of socket union (A) and double cone sleeve (B)	4	M8x1	404-002	404-001	–
Solderless pipe connection for plastic pipe* consisting of socket union (A), reinforcing socket (B), and tapered sleeve (C)	4	M8x1	404-612	404-603	404-611

* For more information, → page 14.

SKF MonoFlex prelubrication distributors of product series VR

General

SKF MonoFlex single-line distributors of product series VR are 1- to 12-port prelubrication distributors for MonoFlex single-line centralized lubrication systems for fluid grease and grease lubrication with greases up to NLGI Grade 2. SKF MonoFlex single-line distributors of product series VR are characterized by an innovative, compact, and sturdy design with SKF plug connector systems. With a high pressure resistance of up to 315 bar and selectable relief pressures of 30 or 70 bar, these single-line distributors allow use of single-line centralized lubrication systems, especially as an inexpensive alternative to dual-line centralized lubrication systems that are currently in use. These single-line distributors offer a broad range of possible applications due to their high level of functional reliability, especially when using greases of NLGI Grades 1 and 2, and at low ambient temperatures down to -25°C. SKF MonoFlex single-line distributors of product series VR are designed for corrosivity categories C3 and C5 per DIN EN ISO 12944 and are certified by Germanischer Lloyd. Typical applications are onshore and offshore wind energy systems, large construction machinery, the steel industry and heavy industry, as well as general mechanical engineering applications. The available metered quantities for SKF MonoFlex VR single-line distributors are in the range from 0,1 to 1,3 cm³. The metering nipples have a mark indicating the metered quantity. All metering nipples are equipped standard with an indicator pin that allows visual monitoring of the metering function. The lubrication point line is connected to the single-line distributor using SKF plug connectors or cutting-sleeve screw unions. In addition, a thread connection sized G1/8 is available for utilizing customer-specific fittings. The diameter of the connectable lubrication point line can be either 4 mm or 6 mm, depending on the design. Non-adjustable and adjustable meterings are available. For adjustable meterings, the metered quantity is in the range from 0,1 cm³ to 1,1 cm³ and is regulated by the engagement depth of the metering nipple. The adjustable meterings are factory-set to a metered quantity of 1,1 cm³.



The components made of elastomers inside the single-line distributor are made of FKM (FPM). The distributor body is made from aluminum. The surface is anodized (black color) for long-term protection against corrosion.

The main line connection on the distributor body has a G 1/4 (DIN 3852-2 Form X) thread. SKF MonoFlex single-line distributors of product series VR can be equipped with fittings for the main line connection. Cutting-sleeve screw unions (DIN 2353) for pipe diameters of 8 mm or 10 mm or screw plugs that are matched to the thread size of the main line connection are available. This can be indicated on the order by selecting the corresponding letter for the desired combination of fittings in the order code.

See the following pages for further information on product series VR. Details on accessories for SKF MonoFlex single-line centralized lubrication systems are part of this catalog.

! The configurator on the following page allows specification of a distributor of product series VR, complete with metering nipples and main line fittings in a single order code.

SKF MonoFlex prelubrication distributors of product series VR

Dimensions

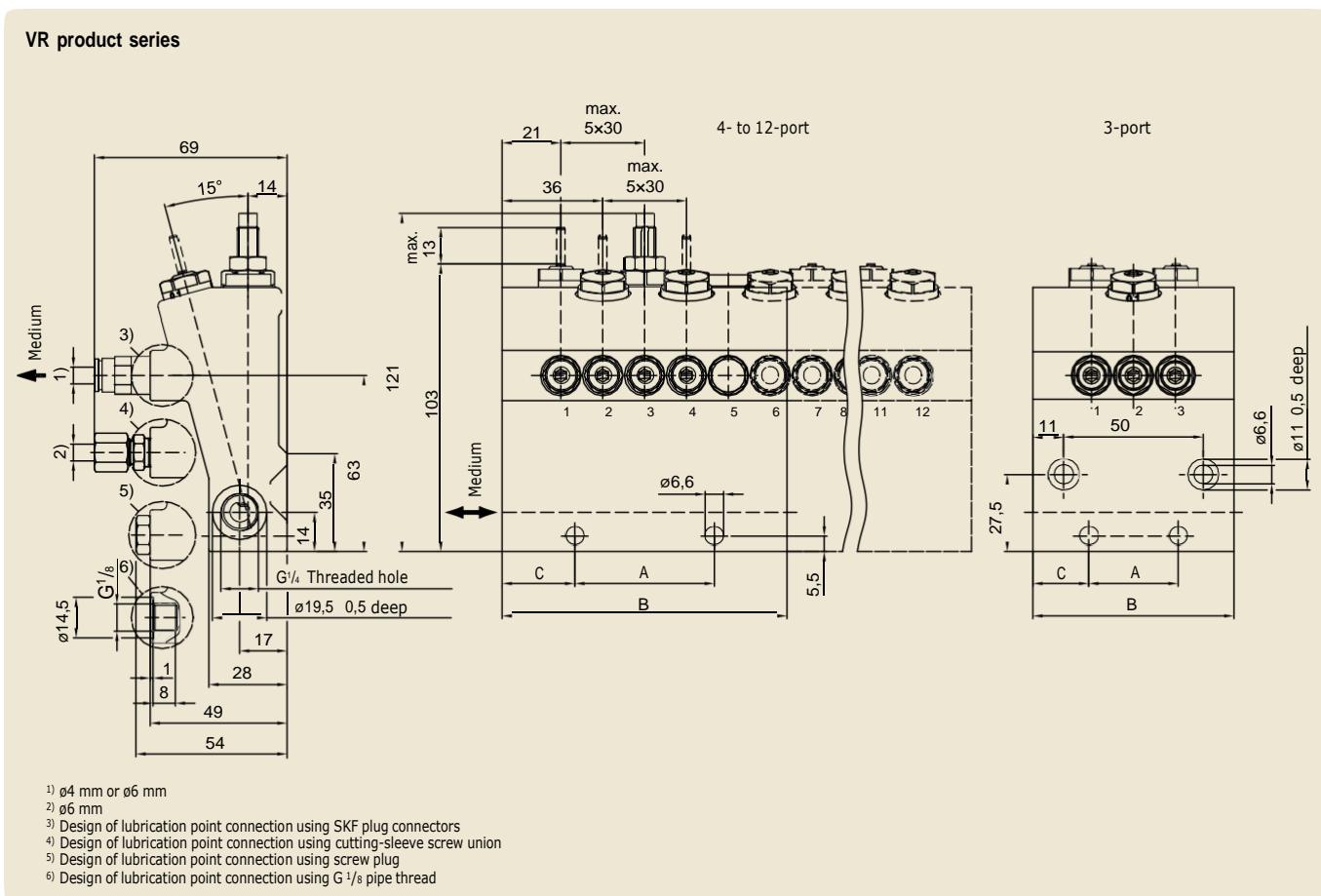

Dimensions

Number of outlets	1	2	3	4	5	6	7	8	9	10	11	12
Dim. A [mm]	1 bore on center		32	50	50	50	50	50	50	50	50	50
Dim. B [mm]	42	57	72	87	102	117	132	147	162	177	192	207
Dim. C [mm]	21	28,5	20	18,5	26	33,5	41	48,5	56	63,5	71	78,5

SKF MonoFlex prelubrication distributors of product series VR

Dimensions - Fittings for main line connection

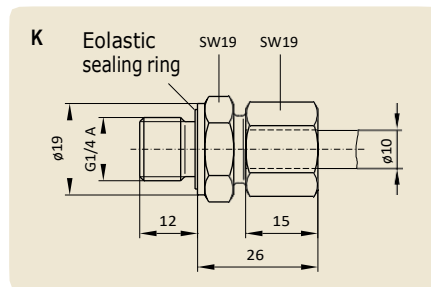
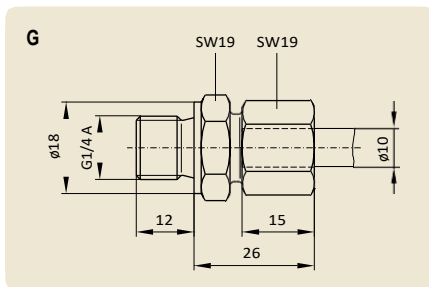
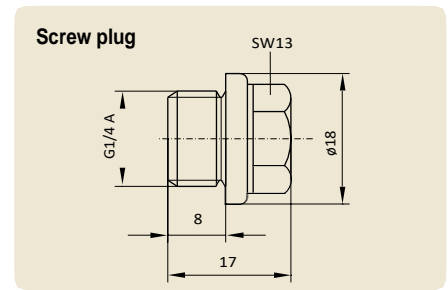
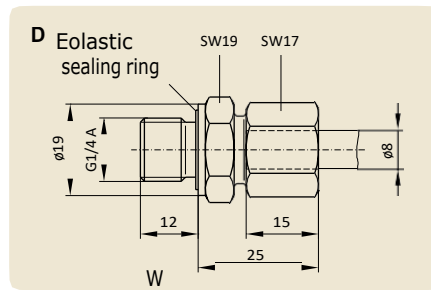
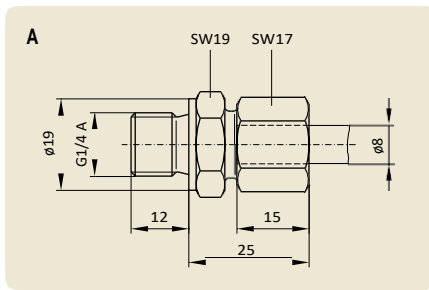

Technical data

Pressures and temperatures

Operating pressure	min. 100 bar max. 315 bar
Relief pressure selectable	max. 30 bar max. 70 bar
Lubricant	Fluid greases and greases up to NLGI Grade 2
Operating temperature	-25 to + 80°C

Materials

Distributor body	Anodized aluminum
Metering nipple	Anodized aluminum/ stainless steel
Indicator pin	Stainless steel (1.4401)
Elastomers	FKM (FPM)

Mark on metering nipple

Metering [cm ³]	Mark
0,1	0,1
0,2	0,2
0,4	0,4
0,6	0,6
0,8	0,8
1,0	1,0
1,3	1,3

! The 30-bar relief pressure should be selected in case of low flow pressure and low operating temperature of the lubricant, or when using a short main line or a large main line diameter.

The 70-bar relief pressure should be selected in case of high flow pressure and low operating temperature of the lubricant, and when using a long main line or a small main line diameter.

SKF MonoFlex prelubrication distributors of product series 321

General

321 G7



321 G4



321 Module



SKF MonoFlex single-line distributors of product series 321 are special types of single-port prelubrication distributors for SKF MonoFlex single-line centralized lubrication systems for oil and fluid grease lubrication. These single-line distributors are designed for installation directly in a lubrication point, which eliminates the feeding of lubricant to the lubrication point via a lubrication point line as well as the lubrication line at the lubrication point. This can be beneficial where, for example, space is limited. The single-line distributors are integrated directly into the main line of the MonoFlex single-line centralized lubrication system.

A total of six special types are available that differ according to their intended application.

The available metered quantities are in the range from 0,01 – 0,30 cm³ depending on the special type. The single-line distributors have a mark indicating the metered quantity. The main line is connected to single-line distributor types G, T, and W using union nuts or socket unions combined with tapered sleeves. Main lines can be connected that are made of metal pipe, plastic pipe, or hose lines with metal pipe connectors.

The single-line distributor types G, T, and W are connected to lubrication points using a tapered threaded end; depending on the design, M8x1 taper, M10x1 taper, or R1/8 taper can be selected. See the following pages for details on lubricant feeding and the lubrication point connection on special types G4, G7 (small and large design) and Module. The components made of elastomers inside the single-line distributors are made of NBR. Several designs of type G7 are also available with elastomers made of FKM (FPM). The distributor body is made of steel (galvanized, Cr6-free) or brass depending on the type.

See the following pages for further information on product series 390. Details on accessories for SKF MonoFlex single-line centralized lubrication systems are part of this catalog.

Note on structure of a single-line centralized lubrication system:

Pressure buildup and reduction in main lines (connection between centralized lubrication unit and single-line distributor) can be monitored using pressure switches. In lubrication point lines (connection between single-line distributor and lubrication point), the operating pressure generated by the centralized lubrication unit does not appear immediately; the pressure therefore cannot be monitored using pressure switches. Nevertheless, to monitor lubrication point lines and thus lubrication of the bearing, the lubrication point lines must be turned into main lines. This is done using the single-port single-line distributor types G, T, and W. These single-line distributors are placed directly in the main line and feed lubricant directly into the lubrication point without utilizing a lubrication point line. By arranging the single-line distributors in the main line, pressure buildup in the main line can be monitored using pressure switches, which also allows the function of the single-line distributors to be monitored for each lubrication cycle.

321 G



321 T



321 W



SKF MonoFlex prelubrication distributors of product series 321

Order numbers

Product series 321 – designs G, T, W*						
ø lubrication point line [mm]	Lubricant	Metered quantity [cm ³]	Pipe thread of lubrication point line	321 G	321 T	321 W
4	Oil	0,01	M8×1 taper	321-401G1	–	–
			M10×1 taper	321-401G2	321-401T2	321-401W2
			R1/8 taper	321-401G3	–	–
4	Oil	0,03	M8×1 taper	321-403G1	321-403T1	321-403W1
			M10×1 taper	321-403G2	321-403T2	321-403W2
			R1/8 taper	321-403G3	321-403T3	321-403W3
4	Oil	0,06	M8×1 taper	321-406G1	321-406T1	321-406W1
			M10×1 taper	321-406G2	321-406T2	321-406W2
			R1/8 taper	321-406G3	321-406T3	321-406W3
4	Oil	0,10	M8×1 taper	321-410G1	321-410T1	321-410W1
			M10×1 taper	321-410G2	321-410T2	321-410W2
			R1/8 taper	321-410G3	321-410T3	321-410W3
6	Oil, fluid grease NLGI Grade 000, 00	0,01	M8×1 taper	321-601G1	–	321-601W1
			M10×1 taper	321-601G2	321-601T2	321-601W2
			R1/8 taper	–	321-601T3	321-601W3
6	Oil, fluid grease NLGI Grade 000, 00	0,03	M8×1 taper	321-603G1	321-603T1	321-603W1
			M10×1 taper	321-603G2	321-603T2	321-603W2
			R1/8 taper	321-603G3	321-603T3	321-603W3
6	Oil / Fluid grease NLGI Grade 000, 00	0,06	M8×1 taper	321-606G1	–	321-606W1
			M10×1 taper	321-606G2	321-606T2	321-606W2
			R1/8 taper	321-606G3	321-606T3	321-606W3
6	Oil, fluid grease NLGI Grade 000, 00	0,10	M8×1 taper	321-610G1	321-610T1	321-610W1
			M10×1 taper	321-610G2	321-610T2	321-610W2
			R1/8 taper	321-610G3	321-610T3	321-610W3

* Designs G, T, W elastomer material NBR

Product series 321 – designs G4, Module, G7						
Metered quantity [cm ³]	Lubricant	Elastomer material	321 G4	321 Module	321 G7 small	321 G7 large
0,01	Oil/fluid grease NLGI Grade 000, 00	NBR	–	321-101	321-401G7	–
0,03	Oil/fluid grease NLGI Grade 000, 00	NBR	321-403G4	321-103	321-403G7	–
		FKM (FPM)	–	–	321-403G7-S8	–
0,06	Oil/fluid grease NLGI Grade 000, 00	NBR	321-406G4	321-106	321-406G7	–
		FKM (FPM)	–	–	321-406G7-S8	–
0,10	Oil/fluid grease NLGI Grade 000, 00	NBR	321-410G4	–	321-410G7	321-610G7
		FKM (FPM)	–	–	321-410G7-S8	–
0,16	Oil, fluid grease NLGI Grade 000, 00	NBR	–	–	–	321-616G7
0,20	Oil, fluid grease NLGI Grade 000, 00	NBR	–	–	–	321-620G7
0,30	Oil, fluid grease NLGI Grade 000, 00	NBR	–	–	–	321-630G7

SKF MonoFlex prelubrication distributors of product series 321

Dimensions

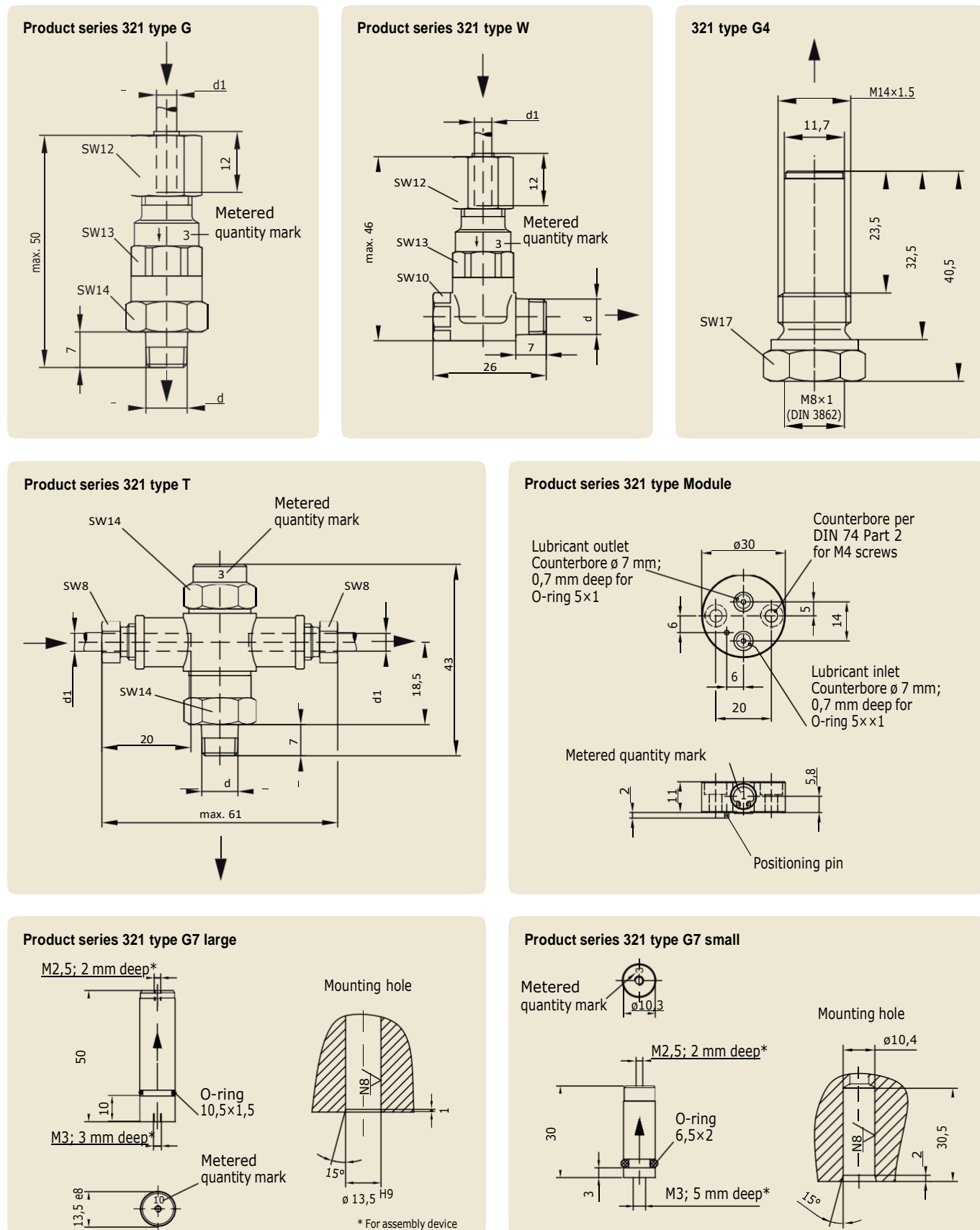

SKF MonoFlex prelubrication distributors of product series 321

Technical data

Pressures and temperatures

Operating pressure min. 12 bar
max. 45 bar

Relief pressure max. 3 bar

Lubricant Mineral and synthetic oil
20 – 2 000 mm²/s; compatible with NBR,
brass, steel

or

Fluid grease of NLGI Grade 000, 00;
compatible with NBR (type G7 small:
also FKM [FPM]), brass, steel

Operating temperature 0 to +80 °C

SKF MonoFlex relubrication distributors of product series VN

General

SKF MonoFlex single-line distributors of product series VN are 2-, 4-, and 6-port relubrication distributors for MonoFlex single-line centralized lubrication systems for fluid grease lubrication. These single-line distributors are designed for installation directly on the vehicle/construction machine requiring lubrication. SKF MonoFlex single-line distributors of product series VN can be ordered with fittings for the main line connection. This can be indicated on the order by selecting the corresponding letter for the desired fitting in the order code.

The available metered quantities are in a range from 0,05 – 1,00 cm³. The metering nipples have a mark indicating the metered quantity. The metering nipples are made of brass. The lubrication point line can be connected to the single-line distributor using SKF quick connectors or solderless pipe connections (DIN 3862). Lubrication point lines can be connected that are made of metal pipe, plastic pipe, or hose lines with metal pipe connectors. The diameter of the lubrication point line that will be connected is 4 mm. The lubrication point outlet can be closed using a locking pin (SKF quick connector) or a screw plug with a flat washer (solderless pipe connection). The metering nipples can be replaced later to yield different metered quantities.

The components made of elastomers inside the multi-port single-line distributors are made of NBR.

The distributor body is made of zinc die-cast. The surface of the distributor bodies is painted black for optimum corrosion protection. Holes to secure the multi-port relubrication distributors to the vehicle/construction machine are cast in the distributor body.

The main line connection on the distributor body has a counterbore for mounting a solderless pipe connection for metal or plastic pipe diameter of 10 mm (M16x1,5 thread). Various fittings, from SKF quick connectors to screw plugs, that are matched to the thread size of the main line connection are available.

See the following pages for further information on product series VN. Details on accessories for SKF MonoFlex single-line centralized lubrication systems are part of this catalog.

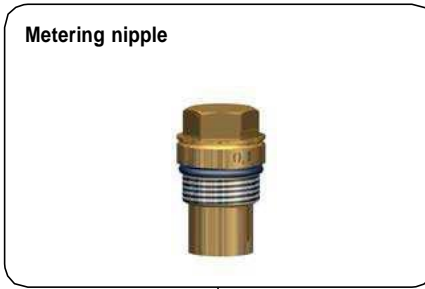

! The following main line fittings A – S can be mounted both on the left and the right of the distributor body. The configurator on the following page allows specification of a single-line distributor with main line fittings in a single order code.

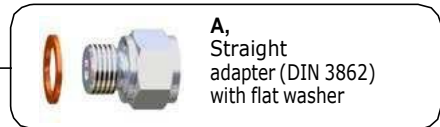

SKF MonoFlex relubrication distributors of product series VN

Configurator

Order code

V

N

-

0

-

-

Product series

Number of metering points (2, 4, 6)

Design and metered quantity

Design code	0	0
Lubricant	Fluid grease	Fluid grease
∅ lubrication point line [mm]	4	4
Distributor body material	Zinc die-cast painted black	Zinc die-cast painted black
Metering nipple material	Brass	Brass
Elastomer material	NBR	NBR
Lubrication point line connection	VS	00
Metered quantity code	1	1
0,05	2	2
0,10	3	3
0,20	4	4
0,30	5	5
0,40	6	6
0,60	7	7
1,00		

Code

Design of lubrication point line connection (VS = SKF quick connectors, 00 = solderless pipe connection)

Metered quantity code

Metering point 1

Metering point 2

Metering point 3 (0 = not present, on VN2)

Metering point 4 (0 = not present, on VN2)

Metering point 5 (0 = not present, on VN2, VN4)

Metering point 6 (0 = not present, on VN2, VN4)

Code for fittings for main line connection on left

Code for fittings for main line connection on right

Order example

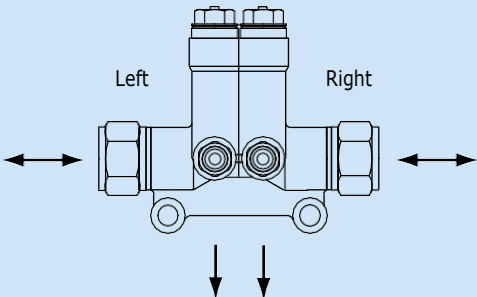

VN2-0VS-330000-AA

- Two-port single-line distributor for fluid grease
- NBR design
- Lubrication point line connection using SKF quick connector for pipe ∅ 4 mm,
- Metered quantity for ports 1 and 2 = 0,20 cm³
- Main line fitting left and right = straight adapter (DIN 3862) with flat washer for pipe ∅ 8 mm

Fittings for main line connection

Description	∅ main line [mm]	Code
Straight adapter DIN 3862 with flat washer ¹⁾	8	A
Banjo fitting DIN 3862 with flat washer, lockable ^{1) 2)}	6	E
	8	F
	10	G
Screw plug with flat washer	-	H
Straight adapter with SKF quick connector	10	S
Without fitting, solderless pipe connection ¹⁾	-	Z

¹⁾ Solderless pipe connection according to DIN 3862 (operating pressure max. 45 bar)
²⁾ Banjo bolt only inserted in delivery condition, not tightened

PUB LS/P2 11213 EN · 1-5001-EN

SKF

59

SKF MonoFlex relubrication distributors of product series VN

Dimensions

Product series VN + solderless pipe connection (00)

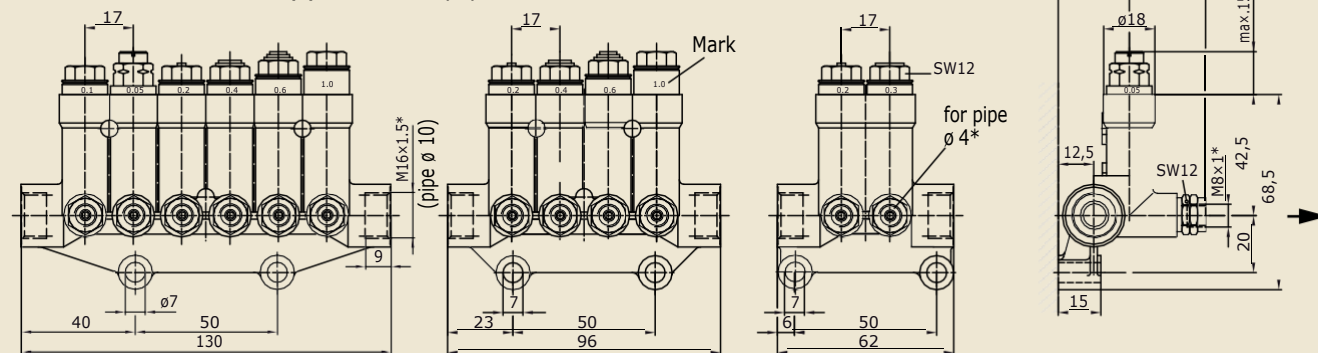

* Counterbore for solderless pipe connection per DIN 3862

Product series VN + SKF quick connector (VS)

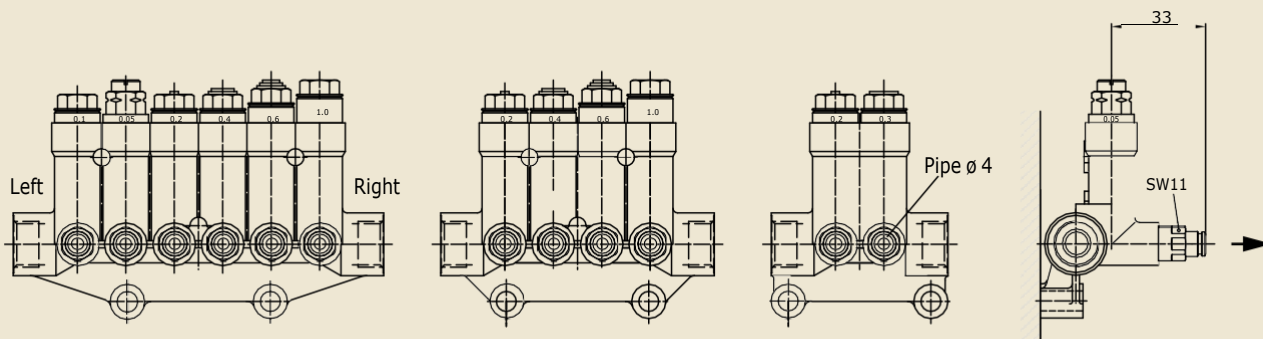

For missing dimensions, → product series VN + solderless pipe connection (00).

Fittings for main line connection

(→ page 54 for exact designation)

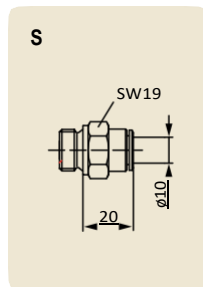
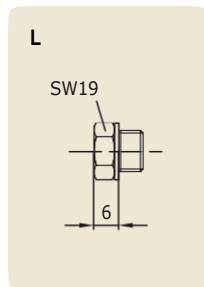
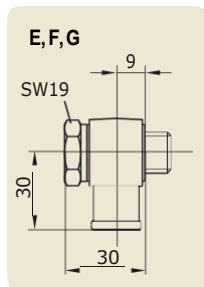
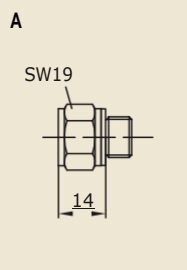

SKF MonoFlex relubrication distributors of product series VN

Technical data

Product series VN

Lubricant	Metered quantity [cm ³]	Lubrication point line connection	Operating pressure [bar]		Relief pressure [bar]	Operating temperature [°C]
			min.	max.		
Fluid grease of NLGI Grade 000, 00; compatible with zinc die-cast, NBR, brass, steel	0,05 – 1,00	00	20	45	<_1	-25 to +80
		VS	20	80	<_1	-25 to +80

Mark on metering nipple

Metered quantity [cm ³]	Mark
0,05	0,05
0,10	0,1
0,20	0,2
0,30	0,3
0,40	0,4
0,60	0,6
1,00	1,0

Accessories

Order numbers for metering nipples* (replaceable)

ø Lubrication point line [mm]	Elastomer material	Metered quantity [cm ³]						
		0,05	0,10	0,20	0,30	0,40	0,60	1,00
4	NBR	VKU005-K	VKU010-K	VKU020-K	VKU030-K	VKU040-K	VKU060-K	VKU100-K

* Metering nipples are made of brass.

Fittings for metering nipples

Description	ø lubrication point line [mm]	Pipe thread	Order number		
			A	B	C
Screw plug with flat washer for solderless pipe connection	4	M8x1	404-011.U1	-	-
Locking pin (A) for SKF quick connectors	4	-	450-204-002	-	-
Solderless pipe connection for metal pipeline* consisting of socket union (A) and double cone sleeve (B)	4	M8x1	404-002	404-001	-
Solderless pipe connection for plastic pipe* consisting of socket union (A), reinforcing socket (B), and tapered sleeve (C)	4	M8x1	404-612	404-603	404-611

* For more information, → page 14.

SKF MonoFlex relubrication distributors of product series 370

General

SKF MonoFlex single-line distributors of product series 370 are 2-, 3-, and 5-port relubrication distributors for MonoFlex single-line centralized lubrication systems for oil lubrication. These single-line distributors are designed for installation directly on the machine / system requiring lubrication. SKF MonoFlex single-line distributors of product series 370 can be ordered with fittings for the main line connection. This can be indicated on the order by selecting the corresponding letter for the desired fitting in the order code.

The available metered quantities are in a range from 0,05 – 1,50 cm³. The metering nipples have a mark indicating the metered quantity. The metering nipples are made of brass. The lubrication point line can be connected to the single-line distributor using SKF quick connectors or solderless pipe connections (DIN 3862). Lubrication point lines can be connected that are made of metal pipe, plastic pipe, or hose lines with metal pipe connectors. The diameter of the lubrication point line that will be connected is 4 mm. The lubrication point outlet can be closed using a locking pin (SKF quick connector) or a screw plug with a flat washer (solderless pipe connection). The metering nipples can be replaced later to yield different metered quantities.

The components made of elastomers inside the multi-port single-line distributors are made of NBR.

The distributor body is made of zinc die-cast. Holes to secure the multi-port relubrication distributors to the machine / system are cast in the distributor body.

The main line connection on the distributor body has an M12x1 tapped bore. Various fittings, from SKF quick connectors to screw plugs, that are matched to the thread size of the main line connection are available.

See the following pages for further information on product series 370. Details on accessories for SKF MonoFlex single-line centralized lubrication systems are part of this catalog.

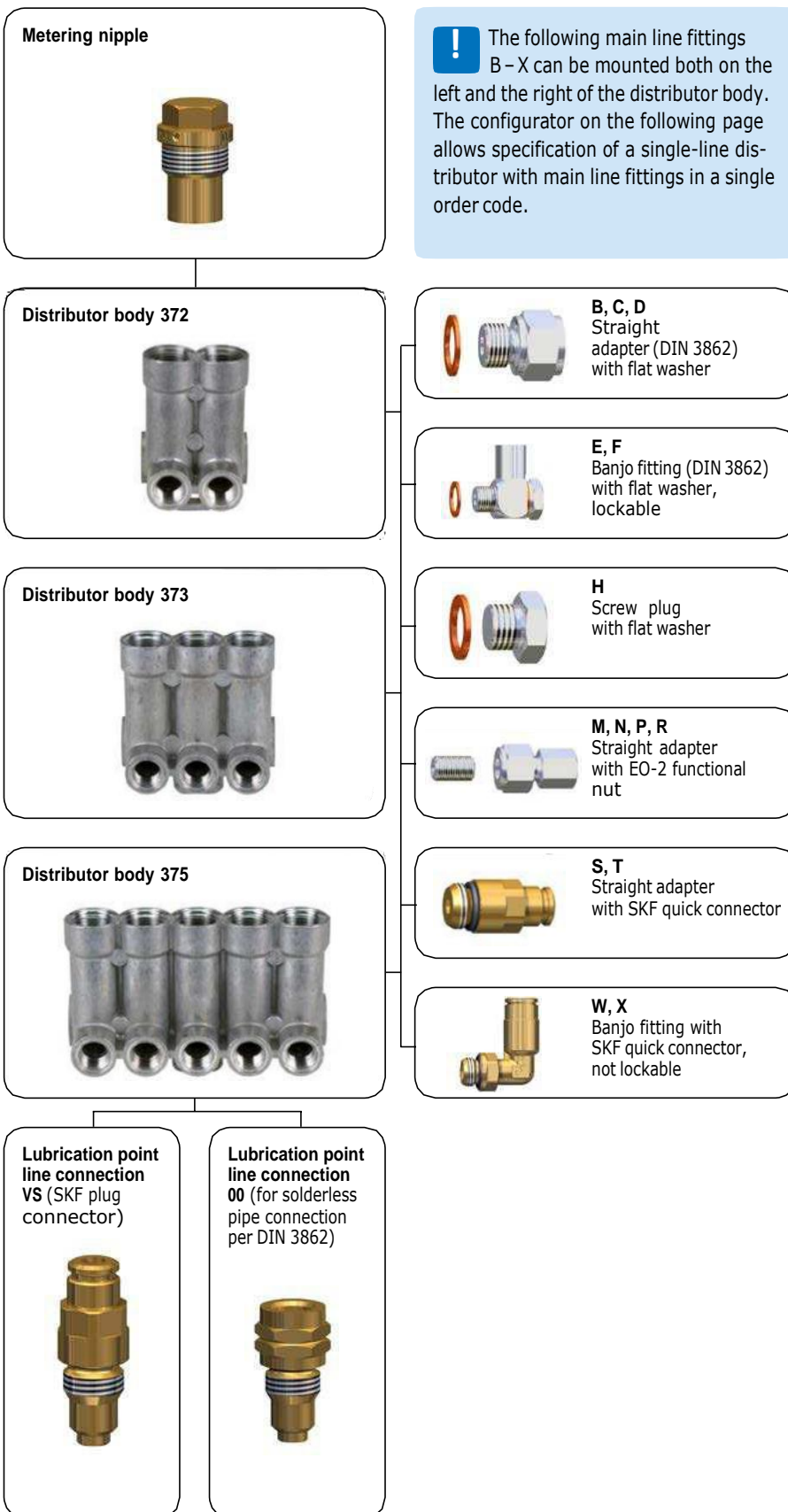

SKF MonoFlex relubrication distributors of product series 370

Dimensions

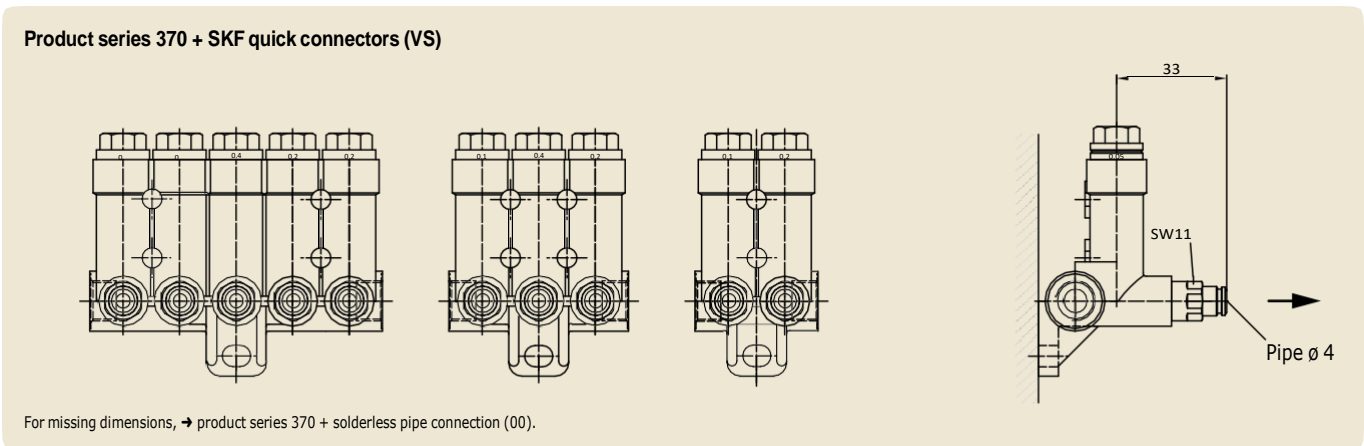
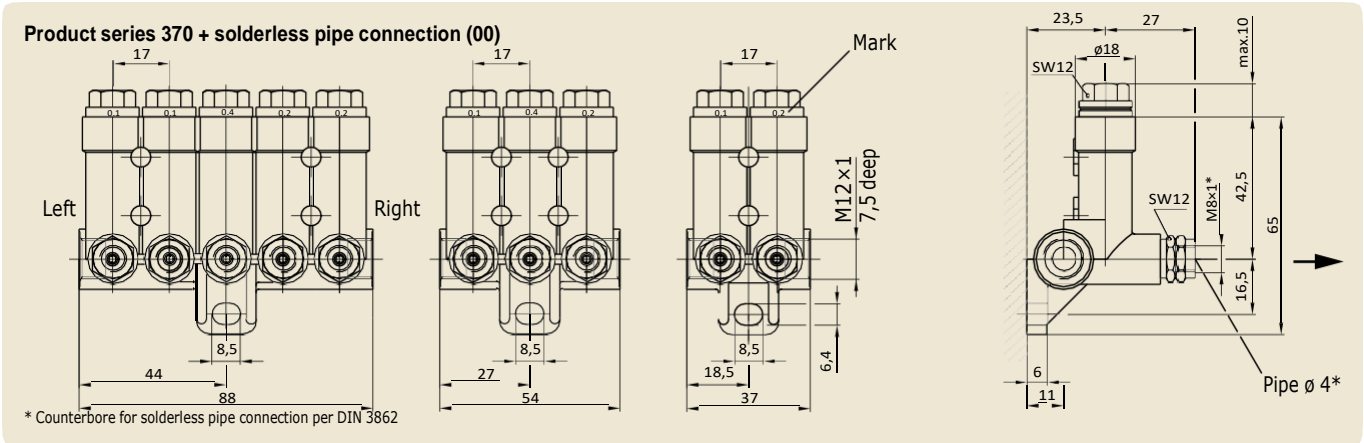

Fittings for main line connection (→ page 58 for exact designation)

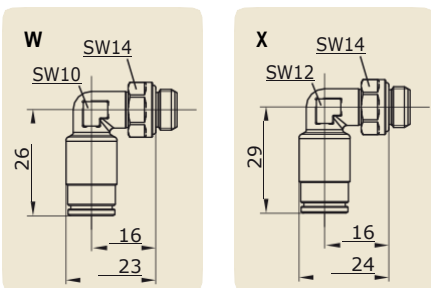
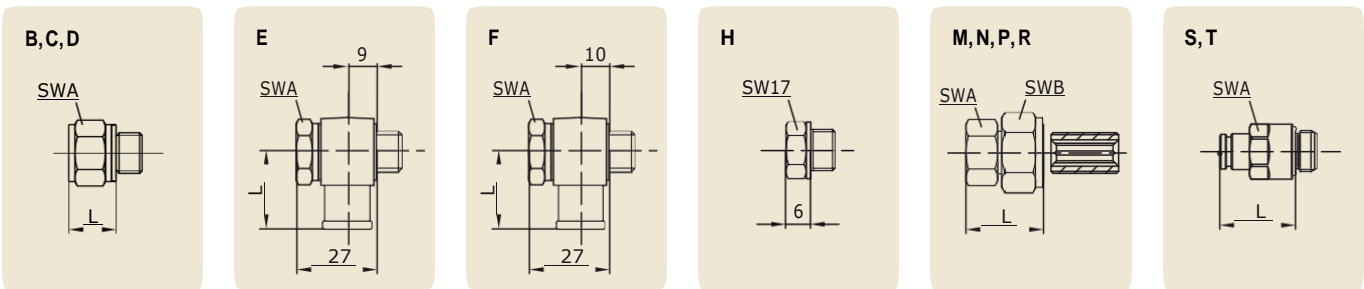

Widths across flats and lengths

Code	B	C	D	E	F	M	N	P	R	S	T
ø main line [mm]	6	8	10	6	8	6	8	10	12	6	8
SWA	17	17	19	17	17	14	17	19	22	14	14
SWB	-	-	-	-	-	19	19	19	19	-	-
Length L [mm]	10	20	22	25	27	32	32	31	31	21	26

SKF MonoFlex relubrication distributors of product series 370

Technical data

Product series 370

Lubricant	Metered quantity [cm ³]	Lubrication point line connection	Operating pressure [bar]		Relief pressure [bar]	Operating temperature [°C]
			min.	max.		
Mineral and synthetic oil 20 – 2 000 mm ² /s; compatible with zinc die-cast, NBR, brass, steel	0,05 – 1,5	00	20	40	<_1	-25 to +80
		VS	20	80	<_1	-25 to +80

Mark on metering nipple

Metered quantity [cm ³]	Mark
0,05	0,05
0,10	0,1
0,20	0,2
0,40	0,4
0,60	0,6
1,00	1,0
1,50	1,5

Accessories

Order numbers for metering nipples* (replaceable)

ø lubrication point line [mm]	Elastomer material	Metered quantity [cm ³]						
		0,05	0,10	0,20	0,40	0,60	1,00	1,50
4	NBR	V72-005	V71-010	V71-020	V71-040	V71-060	V71-100	V71-150

* Metering nipples are made of brass.

Fittings for metering nipples

Description	ø lubrication point line [mm]	Pipe thread	Order number		
			A	B	C
Screw plug with flat washer for solderless pipe connection	4	M8x1	404-011.U1	–	–
Locking pin (A) for SKF quick connectors	4	–	450-204-002	–	–
Solderless pipe connection for metal pipeline* consisting of socket union (A) and double cone sleeve (B)	4	M8x1	404-002	404-001	–
Solderless pipe connection for plastic pipes* consisting of socket union (A), reinforcing socket (B), and tapered sleeve (C)	4	M8x1	404-612	404-603	404-611

* For more information, → page 14.

SKF MonoFlex dynamic distributors of product series 361

General

SKF MonoFlex single-line distributors of product series 361 are single-port dynamic distributors for MonoFlex single-line centralized lubrication systems for oil and fluid grease lubrication. These single-line distributors are designed for installation in manifolds. The combination of these single-line distributors with 1- to 6-port manifolds provides flexible options for designing the lubrication system on the machine/system requiring lubrication. Manifolds customized for product series 361 are available in an aluminum design.

The available metered quantities are in a range from 0,01 – 0,20 cm³. The distributor bodies have a mark indicating the metered quantity. Depending on the minimum actuating pressure, the single-line distributors can only be used for oil (minimum actuating pressure of 8 bar) or for oil and fluid grease (minimum actuating pressure of 25 bar).

The lubrication point line is connected to the dynamic distributor using a tapered sleeve union consisting of a tapered sleeve and a union nut. Lubrication point lines can be connected that are made of metal pipe, plastic pipe, or hose lines with metal pipe connectors. The diameter of the lubrication point line that will be connected is 4 mm.

The components made of elastomers inside the single-port single-line distributor are made of NBR.



The distributor body of the design for oil is made of brass. The design for oil/fluid grease has a distributor body made of steel (galvanized, Cr6-free). The seal of the internal thread for mounting the single-port single-line distributor in a manifold is available in a flat washer design.

See the following pages for further information on product series 361. Details on accessories for SKF MonoFlex single-line centralized lubrication systems are part of this catalog.

Note on structure of a single-line centralized lubrication system:

MonoFlex single-line centralized lubrication systems with dynamic distributors can be equipped with a 4/2 directional control valve. The single-line centralized lubrication system must be designed such that the main line is preloaded to approx. 6 bar when the lubrication unit is running. For the lubrication procedure, the 4/2 directional control valve is switched so that the dynamic distributors are suddenly pressurized. This layout allows a significant increase in the lubrication cycle frequency, as required, for example, for chain lubrication when using small chain links or at high chain speeds. This allows lubrication cycle frequencies of up to 5 cycles/second to be achieved using low-viscosity lubricants.

The configurator on the following page does not allow specification of manifolds and distributors in a single order code. The manifolds are listed under Accessories and must be ordered separately.

SKF MonoFlex dynamic distributors of product series 361

Configurator

Order code **3 6 1** - **0 0** - **0 0 0 0** - **0 0**

Product series 3 6 1

Number of metering points (1) 1

Design code 0 0

Design of lubrication point line connection (00 = tapered sleeve union)

Metered quantity code 0 0 0 0

Metered quantity code 0 0

Design and metered quantity

Design code	1	2
Lubricant	Oil, fluid grease	Oil
∅ lubrication point line [mm]	4	4
Distributor body material	Steel, galvanized	Brass
Metering nipple material	Steel, galvanized	Brass
Elastomer material	NBR	NBR
Threaded seal material	Flat washer*	Flat washer*
Lubrication point line connection	00	00
Metered quantity code [cm ³]	0,01 0,02 0,03 0,05 0,10 0,20	1 2 3 4 5 6

* Flat washer must be ordered separately. Order number: 504-019

Order example

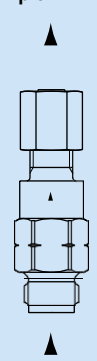

361-200-20000-00

- Single-port single-line distributor for oil
- NBR design
- Lubrication point line connection as tapered sleeve union for pipe ∅ 4 mm
- Metered quantity = 0,02 cm³
- With flat washer seal on internal thread

SKF MonoFlex dynamic distributors of product series 361

Dimensions

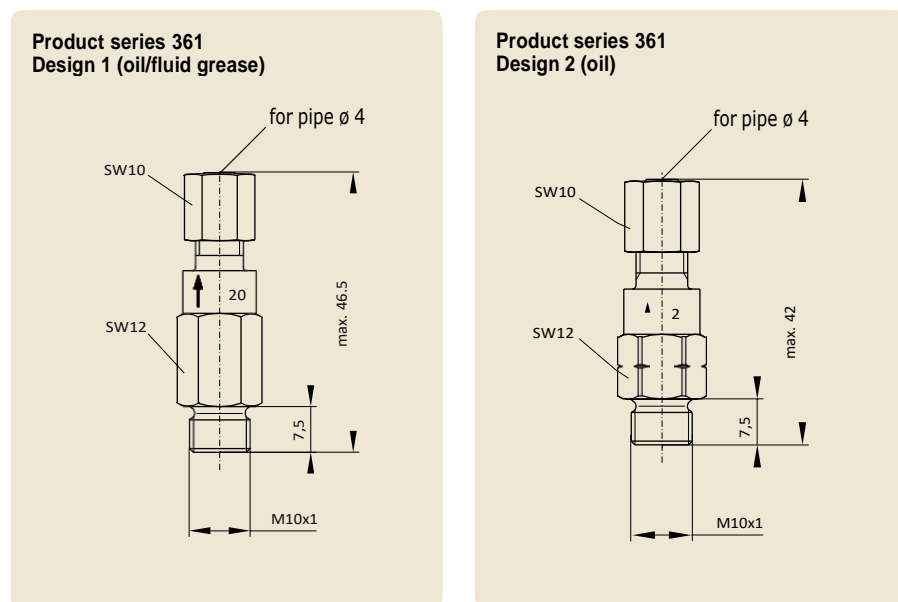

Technical data

Product series 361		Metering quantity [cm ³]	Operating pressure [bar]		Relief pressure [bar]	Operating temperature [°C]
Design	Lubricant		min.	max.		
1	Mineral and synthetic oil 100 - 1 000 mm ² /s and fluid grease of NLGI Grade 000, 00; compatible with NBR, brass, steel	0,01 - 0,20	25	80	<_1	0 - 80
2	Mineral and synthetic oil 10 - 500 mm ² /s; compatible with NBR, brass, steel	0,02 - 0,10	8	40	max. 3	0 - 80

Mark on metering nipple	
Metered quantity [cm ³]	Mark
0,01	1
0,02	2
0,03	3
0,05	5
0,10	10
0,20	20

Tightening torque for assembly		
Distributor	Seal	Tightening torques [Nm]
361-xxx-x0000-00	Flat washer	10

SKF MonoFlex dynamic distributors of product series 361

Manifolds for product series 361

Order code

V L - [] [] [] A [] []

Product series

Number of ports

01 = 1 screw-in point 04 = 4 screw-in points
 02 = 2 screw-in points 05 = 5 screw-in points
 03 = 3 screw-in points 06 = 6 screw-in points
 (other numbers of ports available on request)

Design of distributor pipe thread

E = Small profile, M10x1 with counterbore for flat washer
 G = Normal profile, M10x1 with counterbore for flat washer

Material

A = Aluminum

Design of main line connection

G1 = G1/8 per DIN 3862, Form X, schmal
 G2 = G1/4 per DIN 3862, Form X, schmal
 M3 = M10x1 with counterbore for solderless pipe connection per DIN 3862 (→ page 14)
 M4 = M14x1 with counterbore for solderless pipe connection per DIN 3862 (→ page 14)
 (can only be selected for normal profile)

Order example

VL-02BAM3

- Product series VL
- 2 ports
- Normal profile made of aluminum
- M10x1 internal thread with counterbore for flat washer
- M10x1 main line connection with counterbore for solderless pipe connection per DIN 3862

Dimensions

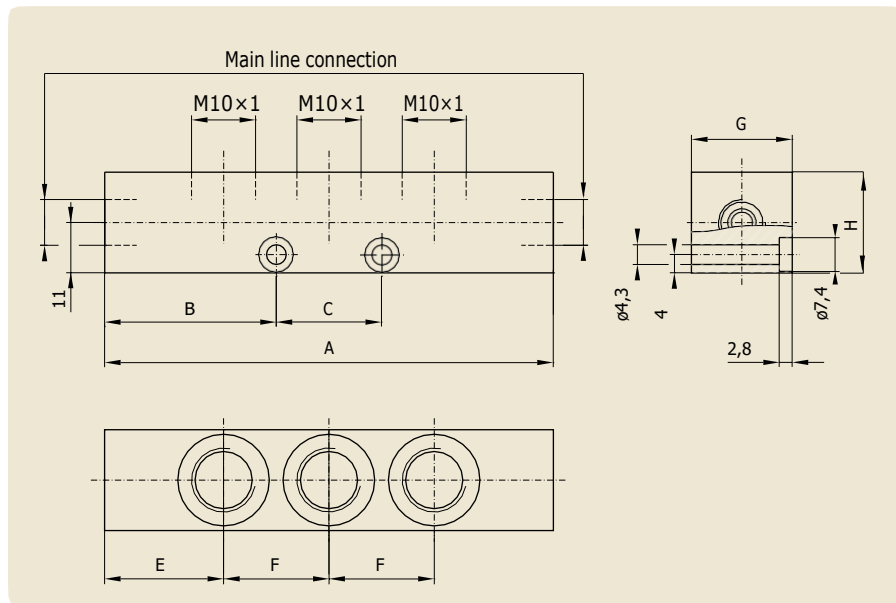

Normal profile G
Main line connection M10x1
 Number Maße [mm]
 of ports A B C E F G H

1	40	20	-	20	-	22	22
2	57	28,5	-	20	1x17	22	22
3	74	28,5	17	20	2x17	22	22
4	91	28,5	34	20	3x17	22	22
5	108	28,5	51	20	4x17	22	22
6	125	28,5	60	20	5x17	22	22

Normal profile G
Main line connection M14x1,5
 Number Maße [mm]
 of ports A B C E F G H

1	52	26	-	26	-	22	22
2	69	34,5	-	26	1x17	22	22
3	86	34,5	17	26	2x17	22	22
4	103	34,5	34	26	3x17	22	22
5	128	34,5	51	26	4x17	22	22
6	137	34,5	68	26	5x17	22	22

Small profile E
Main line connection M10x1
 Number Maße [mm]
 of ports A B C E F G H

1	41	20,5	-	20,5	-	18	20
2	58	29	-	20,5	1x17	18	20
3	75	37,5	-	20,5	2x17	18	20
4	92	29	34	20,5	3x17	18	20
5	109	29	51	20,5	4x17	18	20
6	126	29	68	20,5	5x17	18	20

Normal profile G
Main line connection G1/8
 Number Maße [mm]
 of ports A B C E F G H

1	34	17	-	17	-	22	22
2	51	25,5	-	17	1x17	22	22
3	68	25,5	17	17	2x17	22	22
4	85	25,5	34	17	3x17	22	22
5	102	25,5	51	17	4x17	22	22
6	119	25,5	68	17	5x17	22	22

Normal profile G
Main line connection G1/4
 Number Maße [mm]
 of ports A B C E F G H

1	46	23	-	23	-	22	22
2	63	31,5	-	23	1x17	22	22
3	80	31,5	17	23	2x17	22	22
4	97	31,5	34	23	3x17	22	22
5	114	31,5	51	23	4x17	22	22
6	131	31,5	68	23	5x17	22	22

PUBLS/P2 11213 EN · 1-5001-EN

The Power of Knowledge Engineering

Combining products, people, and application-specific knowledge, SKF delivers innovative solutions to equipment manufacturers and production facilities in every major industry worldwide. Having expertise in multiple competence areas supports SKF Life Cycle Management, a proven approach to improving equipment reliability, optimizing operational and energy efficiency and reducing total cost of ownership.

These competence areas include bearings and units, seals, lubrication systems, mechatronics, and a wide range of services, from 3-D computer modelling to cloud-based condition monitoring and asset management services.

SKF's global footprint provides SKF customers with uniform quality standards and worldwide product availability. Our local presence provides direct access to the experience, knowledge and ingenuity of SKF people.



CAD models for products shown in this brochure can be downloaded at:
skf-lubrication.partcommunity.com

Additional brochures for further information

1-0103-EN	<i>Fittings and Accessories</i>
1-0116-EN	<i>Filters</i>
1-1202-EN	<i>Gear pump units product series MFE</i>
1-1203-EN	<i>Gear pump units product series MKx</i>
1-1701-EN	<i>Pressure Switches Product series DSA, DSB, DSC, DSD</i>
1-3030-EN	<i>Reservoir pump units of the KFG (S)(C) series</i>
1-9201-EN	<i>Transport of Lubricants in Centralized Lubrication Systems</i>

SKF Lubrication Systems Germany GmbH

Berlin Plant
Motzener Str. 35/37 · 12277 Berlin
PO Box 970444 · 12704 Berlin · Germany

Tel. +49 (0)30 72002-0
Fax +49 (0)30 72002-111

This brochure was presented to you by:

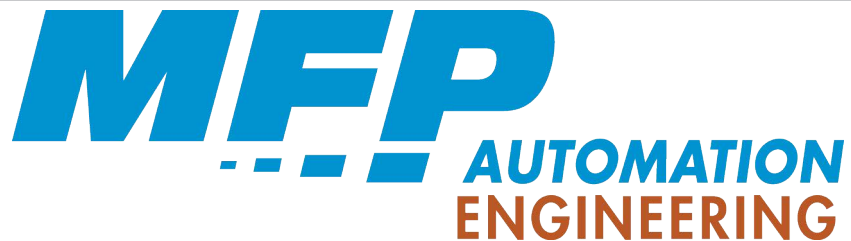

© SKF and MONOFLEX are registered trademarks of the SKF Group.

© SKF Group 2016

The contents of this publication are the copyright of the publisher and may not be reproduced (even extracts) unless prior written permission is granted. Every care has been taken to ensure the accuracy of the information contained in this publication but no liability can be accepted for any loss or damage whether direct, indirect or consequential arising out of the use of the information contained herein.

PUB LS/P2 11213 EN · October 2016 · 1-5001-EN

This publication supersedes publication 1-5015-EN · 1-5009-EN · 1-0998-EN.

